

The right choice for the ultimate yield!

LS ELECTRIC strives to maximize your profits in gratitude for choosing us as your partner.

BACNET/IP Option Module

LSLV-H100 series

User's Manual

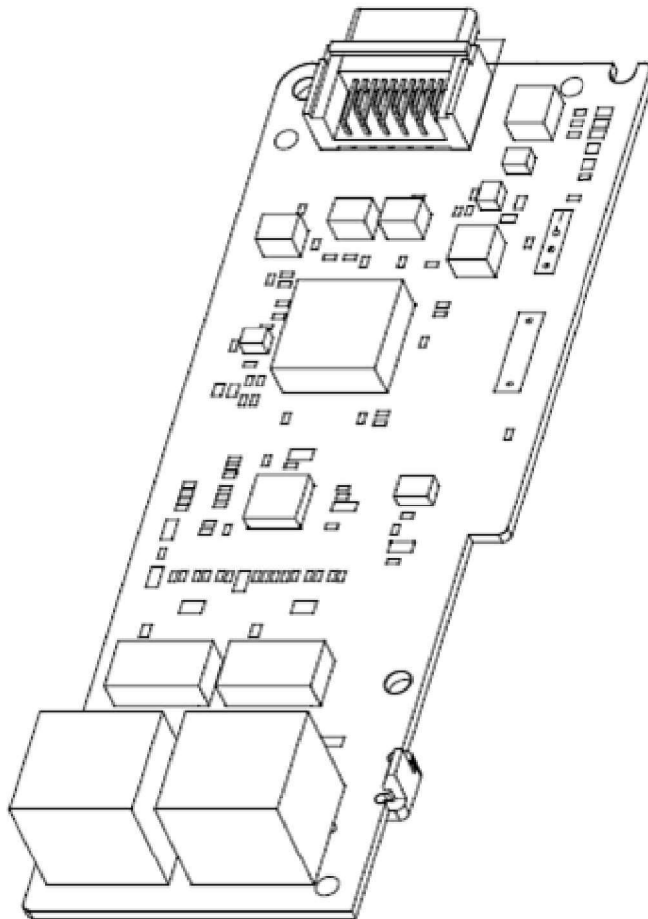

Safety Instructions

- Read this manual carefully before installing, wiring, operating, servicing or inspecting this equipment.
- Keep this manual within easy reach for quick reference.

LSELECTRIC

Before using the product

Thank you for purchasing the H100 Ethernet communication module.

Safety information

- Always follow safety instructions to prevent accidents and potentially hazardous situations.
- Safety precautions are classified into “WARNING” and “CAUTION,” and their meanings are as follows:

Warning

Indicates a potentially hazardous situation which, if not avoided, may cause death or serious injury.

Caution

Indicates a potentially hazardous situation which, if not avoided, may cause minor injury or damage to the product.

- Symbols used in this document and on the product indicate the following.

 Read and follow the instructions carefully to avoid dangerous situations.

 Presence of "dangerous voltage" inside the product that may cause harm or electric shock.

- Keep the operating instructions handy for quick reference.
- Read the operating instructions carefully to fully understand the functions of the H100 series inverters and use them properly.

Caution

- **Be careful not to damage the CMOS elements on the communication module.** Static charge may cause malfunctioning of the product.
- **Turn off the inverter before connecting communication cables.** Otherwise, the module may be damaged or a communication error may result.
- **Correctly align the communication module to the installation connector for installation and ensure that it is firmly connected to the inverter.** Otherwise, the module may be damaged or a communication error may result.
- **Check the parameter units when configuring the parameter values.** Otherwise, a communication error may occur.

Table of Contents

1 Overview	1
2 Ethernet Technical Features	2
3 Package components	3
4 Product model type	3
5 Product layout and installation	3
5.1 External layout.....	3
5.2 Installing the H100 communication module.....	3
6 Network connection	6
6.1 Network connection cable wiring.....	6
6.2 Communication cable connector.....	6
7 Network cable specifications	8
7.1 Frequency band.....	8
7.2 Twisted pair cable types	8
8 Inverter communication address	9
9 Keypad parameters for the Ethernet communication module	10
10 Description of keypad parameters related to the Ethernet communication module	15
10.1 Description of keypad parameters (simplified)	15
10.2 CNF group.....	18
10.3 DRV group.....	18
10.4 COM group.....	18
10.5 PRT group (Lost Command).....	23

11 Services for the LS ELECTRIC products or other manufacturer's products .	24
11.1 Overview	24
11.2 BACnet/IP	24
11.2.1 What is BACnet communication?	24
11.2.2 BACnet Communication Standards	24
11.2.3 BACnet Quick Communication Start.....	25
11.2.4 Protocol Implement.....	28
11.2.5 Object Map.....	28
11.3 EtherNet/IP	36
11.3.1 Basic protocol structure	36
11.3.2 Implicit Message	36
11.3.3 Explicit Message.....	43
11.3.4 Supported objects	45
11.4 Modbus TCP.....	54
11.4.1 Modbus/TCP frame structure.....	54
11.4.2 Function codes.....	55
11.4.3 Exception frame.....	59
11.5 LED Indications and troubleshooting.....	60
12 Web server.....	61
12.1 Overview	62
12.2 Logging in.....	62
12.3 Basic layout	63
12.3.1 Dashboard	64
12.3.2 Monitoring	65
12.3.3 Drive Parameter.....	68
12.3.4 Setting.....	69
12.3.5 Alarm.....	71
12.3.6 Notes.....	72

1 Overview

The Ethernet communication module enables the LSLV-H100 inverter to connect to an Ethernet network. The communication module supports three protocols: BACnet/IP, EtherNet/IP, and Modbus TCP.

It performs real-time communication via automated negotiation, forced duplex, and forced speed features. Using the network features, controlling and monitoring of the H100 inverter can be performed via a PLC sequence program or a master module.

With simple network cable wiring, installation times can be reduced and maintenance becomes easier.

(This product is compatible only with the LSLV-H100 inverters running OS versions 1.22 or later.)

2 Ethernet Technical Features

Item	Description
Communication protocol	BACnet/IP, EtherNet/IP, Modbus TCP
Communication speed	10 Mbps, 100 Mbps, Auto
Communication type	Auto Negotiation, Forced Duplex
Communication range	100 m (Twisted Pair)
Max. number of stations	64 stations
Topology	Line/**Ring topology
Communication range	100 m (Twisted Pair)
Recommended cable	UTP, FTP, STP

* The H100 Ethernet communication module supports all BACnet/IP, EtherNet/IP, and Modbus/TCP features.

** The ring topology is available only with the EtherNet/IP protocol.

3 Package components

The package contains the Ethernet communication module (x1), fix screws (x2), plastic cable guide and screw, and a user manual.

4 Product model type

Model type: CBAC-H100

5 Product layout and installation

5.1 External layout

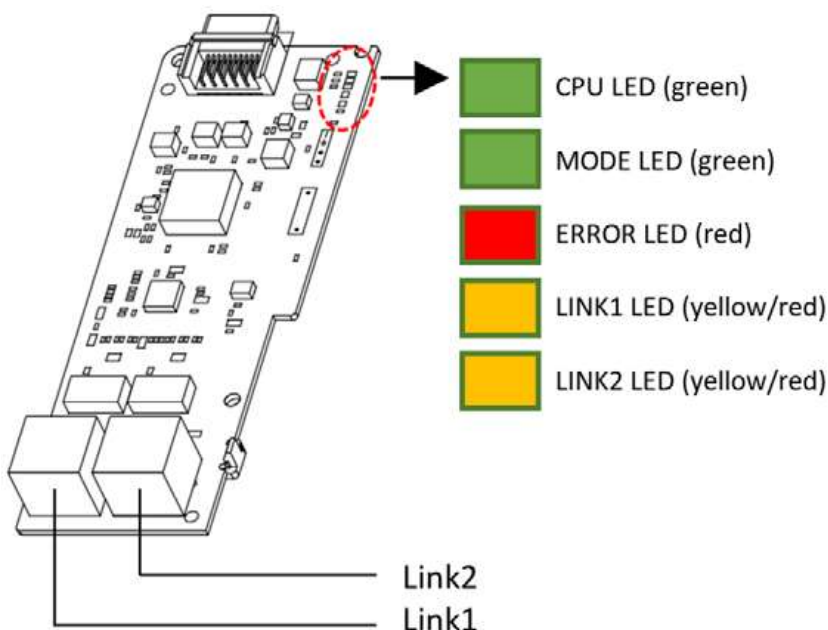

5.2 Installing the H100 communication module

- ① Turn off the H100 inverter and wait until the capacitors are fully discharged.

Then, loosen the bolt that secures the terminal cover and remove the cover by lifting it from the bottom and away from the front.

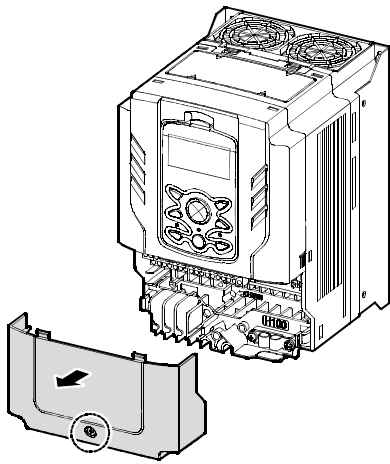

0.75–30 kW Models

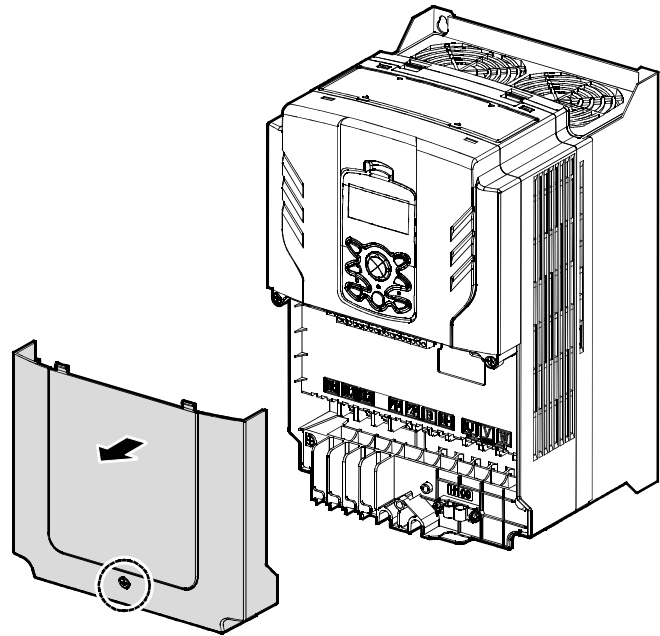

37–90 kW Models

② Remove the keypad from the inverter.

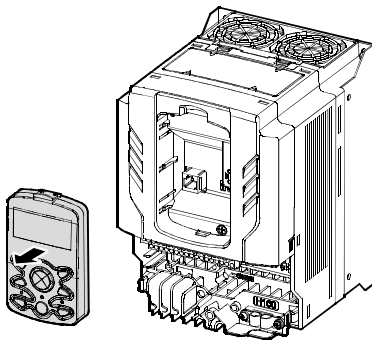

0.75–30 kW Models

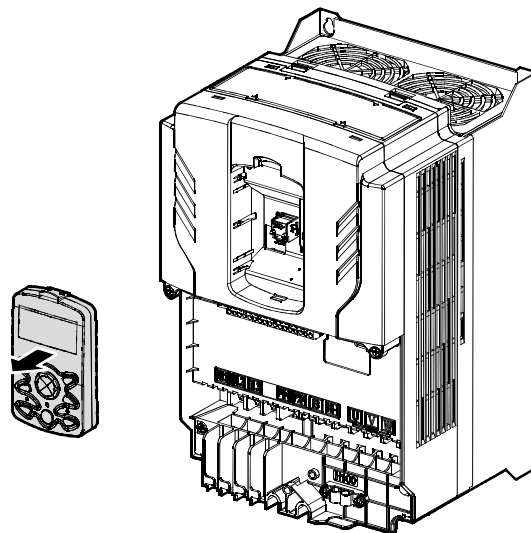

37–90 kW Models

- ③ Loosen the fix screw at the top and lift the cover to remove it.

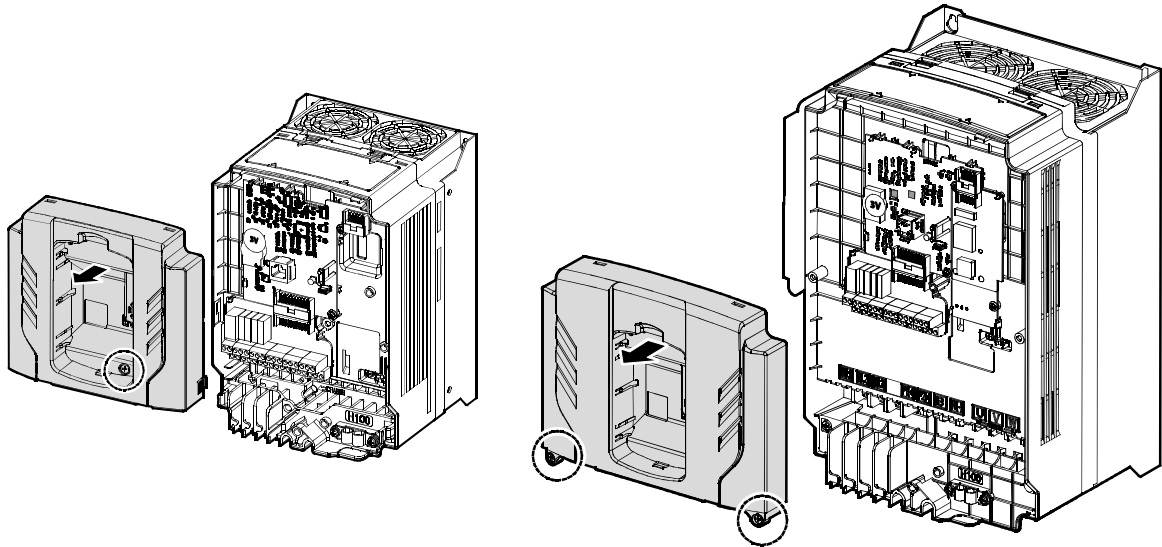

0.75–30 kW Models

37–90 kW Models

- ④ Install the H100 Ethernet communication module to the extension slot on the inverter's I/O board and fix it using the two fix screws (M3, L8) included in the product package.

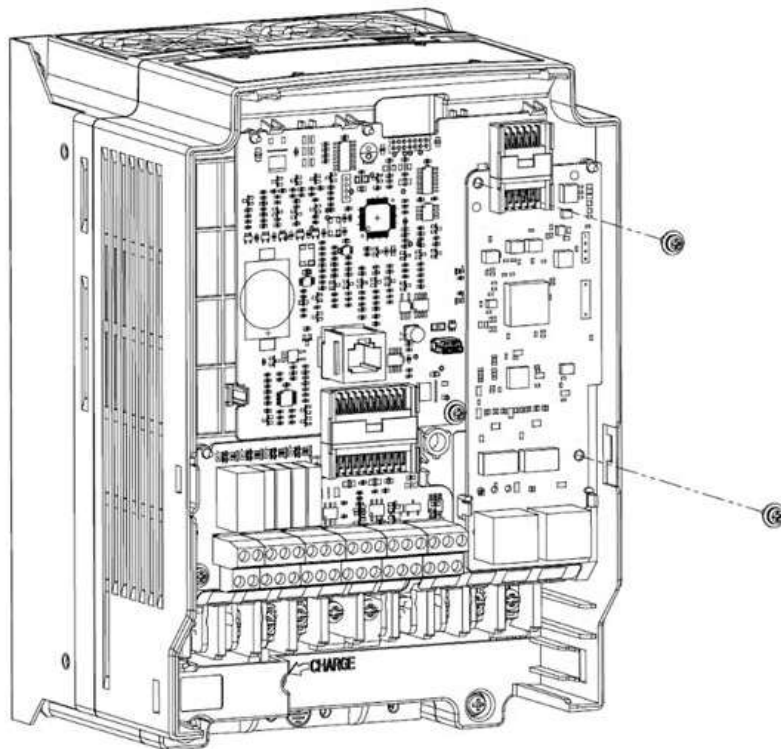

⑤ Install the top cover, keypad, and front cover in the reverse order of the removal.

* The board layout and installation procedures are identical for the inverters rated for more than 110 kW. Refer to the part names listed in Section 1.2 of the H100 User Manual. (You can download the user manual by visiting the website: <http://www.ls-electric.com>).

Warning

- Do not install or remove the Ethernet communication module to or from the H100 inverter while the inverter is turned on.
- Ensure that the electric charge in the capacitors inside the inverter is completely discharged before installing or removing the Ethernet communication module.
- Ensure that the RJ-45 cable is firmly fixed to the inverter and the communication module.

6 Network connection

6.1 Network connection cable wiring

Pin No.	Signal	Description	Cable color
1	TX+	Data transmission (+)	White/Yellow
2	TX-	Data transmission (-)	Yellow
3	RX+	Data reception (+)	White/Green
4	NONE	Not used	Blue
5	NONE	Not used	White/Blue
6	RX-	Data reception (-)	Green
7	NONE	Not used	White/Brown
8	NONE	Not used	Brown

6.2 Communication cable connector

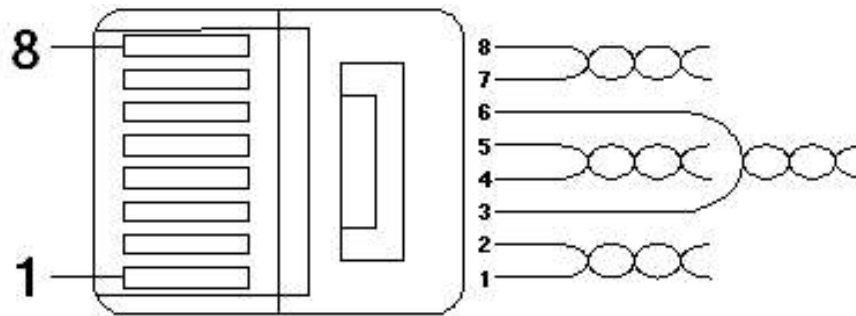

** The cables connected to pin 1 and pin 2 must be twisted in a pair.

** The cables connected to pin 3 and pin 6 must be twisted in a pair.

7 Network cable specifications

7.1 Frequency band

There are five types of UTP cable specifications according to different applications, from category 1 through category 5. Category 5 network cables are required for using the Ethernet communication module.

Category 5 network cables support a frequency band up to 100 MHz, with up to 60 MHz channel performance and up to 100 Mbps data transmission speed.

7.2 Twisted pair cable types

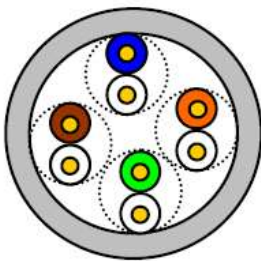

UTP

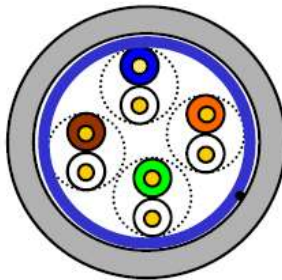

FTP

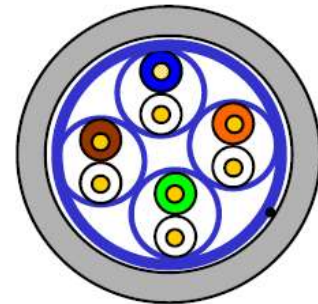

STP

Category	Description	Code
UTP (U.UTP)	Unshielded Twisted Pair cable for high speed signals	200 MHz max. Voice + Data + Low quality video signals
FTP (S.UTP)	Single insulation for the cable core *Insulation: AL/Plastic complex foil or copper braid	100 MHz max. Protection against EMI, electrically stable Voice + Data + Low quality video signals
STP (S.STP)	Dual insulation for the cable pair and the cable core * Cable pair insulation: AL/Plastic complex foil	500 MHz max. Voice + Data + Video signals Replacement for 75Ω coaxial

Category	Description	Code
	* Cable core insulation: AL/Plastic complex foil or copper braid	cable

8 Inverter communication address

Refer to “Chapter 7. Communication features” and “Chapter 8. Table of functions” in H100 User Manual for details.

** You can download H100 User Manual at: <https://www.ls-electric.com>

9 Keypad parameters for the Ethernet communication module

The following table lists the inverter parameters related to BACnet/IP, EtherNet/IP, and Modbus TCP communication features. Application types for each parameter are specified in the “Protocol” column: B (BACnet/IP), E (EtherNet/IP), or M (Modbus/TCP)

Set DRV-06 (Cmd Source) to “4 (Field Bus)” using the keypad to operate the H100 inverter via the Ethernet communication module.

Set DRV-07 (Frq Ref Src) to “7 (Field Bus)” to provide frequency reference via Ethernet communication module.

Keypad parameters related to the H100 Ethernet communication module											
Code #	Parameter name	Default	Range	Description	Protocol						
CNF-30	Option-1 Type	-	-	Indicates the name of communication module installed. 'BACnet IP' (Depending on the inverter version, "Reserved-18" may be displayed instead of "Ethernet.")	B/E/M						
DRV-06	Cmd Source	1	0–5	4: Set to “Field Bus.”	B/E/M						
DRV-07	Freq Ref Src	0	0 - 11	7: Set to “Field Bus.”	B/E/M						
COM-06	FBus S/W Ver	-	-	Indicates the version of the communication module installed.	B/E/M						
COM-09	FBus Led			Displays the ON/OFF status of the LED indicators on the Ethernet communication module.	B/E/M						
COM-10	Opt Parameter 1	0	0 - 1	Sets the dynamic IP allocation feature. DHCP:1 , Static : 0	B/E/M						
COM-11	Opt Parameter 2	Port 1	Port 2	Port 1	Port 2	B3	B2	B1	B0	Set Port1 and Port 2 individually	B/E/M
										1: Full-Duplex, 0: Half-Duplex	
										1: 100 Mbps 0: 10 Mbps	

Keypad parameters for the Ethernet communication module

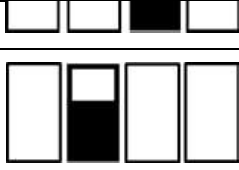
					1: Auto negotiation ON 0: Auto negotiation OFF	
Sets the current switch operation for Port 1 (L) and Port 2 (R). * If the automated negotiation is turned OFF (Bit2: 0), the switch operates according to the Bit1 and Bit0 settings.						
COM-12	Opt Parameter 3	192	0 - 255	Sets the IP address.	B/E/M	
COM-13	Opt Parameter 4	168	0 - 255			
COM-14	Opt Parameter 5	1	0 - 255			
COM-15	Opt Parameter 6	10	0 - 255			
COM-16	Opt Parameter 7	24	1 - 32	Sets the subnet mask. *(Note 1) Refer to the CIDR Subnet Table. Ex) 24: 255.255.255.0	B/E/M	
COM-17	Opt Parameter 8	192	0 - 255	Sets the gateway address.	B/E/M	
COM-18	Opt Parameter 9	168	0 - 255			
COM-19	Opt Parameter 10	1	0 - 255			
COM-20	Opt Parameter 11	1	0 - 255			
COM-21	Opt Parameter 12	0	0 - 2	Sets the protocol option. 0:BACnet/IP , 1:Ethernet/IP , 2:Modbus/TCP	B/E/M	
COM-22	Opt Parameter 13	1	0 - 1	Enables the Keep-Alive feature for the Modbus/TCP protocol. ON:1, OFF:0	M	
COM-23	Opt Parameter 14	600	10 - 65535	Sets the Keep-Alive interval when the Keep-alive feature is enabled. Unit: Second		

Note

After making changes to parameter COM-07 and parameters COM-10 - COM-23, you must set COM-94 (Comm-Update) to “1 (Yes)” to save the changes. When you run the COMM update feature after changing the IP or option type setting, the system will automatically restart.

Parameters COM-22 and COM-23 are available only when COM-21 has been set to “2: Modbus/TCP.”

Keypad parameters related to the H100 Ethernet communication module					
Code #	Parameter name	Default	Range	Description	Protocol
COM-30	Para Status Num	3	0 - 8	Sets the amount of inverter data to be read by the client.	E
COM-31	Para Status-1	000A	0x0000 - 0xFFFF	Sets the inverter data address to be read by the client. (Hex.)	E
COM-32	Para Status-2	000D	0x0000 - 0xFFFF	Sets the inverter data address to be read by the client. (Hex.)	E
COM-33	Para Status-3	000F	0x0000 - 0xFFFF	Sets the inverter data address to be read by the client. (Hex.)	E
COM-34	Para Status-4	-	0x0000 - 0xFFFF	Sets the inverter data address to be read by the client. (Hex.)	E
COM-35	Para Status-5	-	0x0000 - 0xFFFF	Sets the inverter data address to be read by the client. (Hex.)	E
COM-36	Para Status-6	-	0x0000 - 0xFFFF	Sets the inverter data address to be read by the client. (Hex.)	E
COM-37	Para Status-7	-	0x0000 - 0xFFFF	Sets the inverter data address to be read by the client. (Hex.)	E
COM-38	Para Status-8	-	0x0000 - 0xFFFF	Sets the inverter data address to be read by the	E

Keypad parameters for the Ethernet communication module

Keypad parameters related to the H100 Ethernet communication module					
				client. (Hex.)	
COM-50	Para Ctrl Num	2	0 - 8	Sets the amount of inverter data the client will command.	E
COM-51	Para Control-1	0005	0x0000 - 0xFFFF	Sets up the client's command address. (Hex.)	E
COM-52	Para Control-2	0006	0x0000 - 0xFFFF	Sets up the client's command address. (Hex.)	E
COM-53	Para Control-3	-	0x0000 - 0xFFFF	Sets up the client's command address. (Hex.)	E
COM-54	Para Control-4	-	0x0000 - 0xFFFF	Sets up the client's command address. (Hex.)	E
COM-55	Para Control-5	-	0x0000 - 0xFFFF	Sets up the client's command address. (Hex.)	E
COM-56	Para Control-6	-	0x0000 - 0xFFFF	Sets up the client's command address. (Hex.)	E
COM-57	Para Control-7	-	0x0000 - 0xFFFF	Sets up the client's command address. (Hex.)	E
COM-58	Para Control-8	-	0x0000 - 0xFFFF	Sets up the client's command address. (Hex.)	E
COM-84	BAC Dev Inst1	237	0 - 4194	Used to identify BACnet devices. (COM-84 X 1000) + COM-85	B
COM-85	BAC Dev Inst2	0	0 - 999	Used to identify BACnet devices. (COM-84 X 1000) + COM-85	B
COM-86	BAC Password	0	0 - 32768	Refers to the password used for Warm/Cold Start. The password is also used for the web server.	B
COM-94	Comm Update	0	0:NO 1:YES	Updates keypad parameters related to network communication.	B/E/M
PRT-12	Lost Cmd Mode	None	0: None 1: Free-Run 2: Dec 3: Hold Input 4: Hold	Sets the inverter operation for when a Lost Command has occurred. (Note 2)	B/E/M

Keypad parameters for the Ethernet communication module

Keypad parameters related to the H100 Ethernet communication module

			Output 5: Lost Preset		
PRT-13	Lost Cmd Time	1.0	0.1 - 120	Lost Command trigger time	B/E/M
PRT-14	Lost Preset F	0.00	0.05 - 60.00	Sets the Lost Preset speed.	B/E/M

(Note 1) CIDR Subnet Table

NetworkBit	Subnet Mask	NetworkBit	Subnet Mask
1	128.0.0.0	17	255.255.128.0
2	192.0.0.0	18	255.255.192.0
3	224.0.0.0	19	255.255.224.0
4	240.0.0.0	20	255.255.240.0
5	248.0.0.0	21	255.255.248.0
6	252.0.0.0	22	255.255.252.0
7	254.0.0.0	23	255.255.254.0
8	255.0.0.0	24	255.255.255.0
9	255.128.0.0	25	255.255.255.128
10	255.192.0.0	26	255.255.255.192
11	255.224.0.0	27	255.255.255.224
12	255.240.0.0	28	255.255.255.240
13	255.248.0.0	29	255.255.255.248
14	255.252.0.0	30	255.255.255.252
15	255.254.0.0	31	255.255.255.254
16	255.255.0.0	32	255.255.255.255

(Note 2) Lost Command Mode

Parameter Setting	Functions
"None"	Maintains the previous status.

Parameter Setting	Functions
"Free-Run"	Lost Command Trip occurs and a free run stop is made.
"Dec"	Lost Command Trip occurs and a deceleration stop is made.
"Hold Input"	Lost Command Warning occurs and the inverter operates with the previous speed reference.
"Hold Output"	Lost Command Warning occurs and the inverter operates with the previous running speed.
"Lost Preset"	Lost Command Warning occurs and the inverter operates with speed reference set at PRT-14.

10 Description of keypad parameters related to the Ethernet communication module

10.1 Description of keypad parameters (simplified)

The following table lists the simplified information of keypad parameters. The detailed information is provided in the parameter group section.

Code	Parameter name	Description
CNF	30 Option-1 Type	Displays the option slot-1 type
DRV	06 Cmd Source	Command source
	07 Freq Ref Src	Frequency reference source
COM	06 FBus S/W Ver	Communication module S/W version
	07 FBus ID	Station ID of the communication module (communication module ID)
	09 FBus Led	Information about the LED indicators on the communication module

Description of keypad parameters related to the Ethernet communication module

Code	Parameter name	Description
	10 opt para-1	Enter the decimals for operating the DHCP.
	11 opt para-2	Enter the 8-bit values for Port 1 and Port 2 switch status.
	12 opt para-3	Enter the 1st decimal number of the IP address
	13 opt para-4	Enter the 2nd decimal number of the IP address.
	14 opt para-5	Enter the 3rd decimal number of the IP address.
	15 opt para-6	Enter the 4th decimal number of the IP address.
	16 opt para-7	Enter the decimal number for the CIDR SubNet mask.
	17 opt para-8	Enter the 1st decimal number of the Gateway address.
	18 opt para-9	Enter the 2nd decimal number of the Gateway address.
	19 opt para-10	Enter the 3rd decimal number of the Gateway address.
	20 opt para-11	Enter the 4th decimal number of the Gateway address.
	21 opt para-12	Enter the decimal number for the protocol option in use.
	22 opt para-13	Enter the decimal number for the Keep-Alive feature status.
	23 opt para-14	Enter the decimal number for the Keep-Alive interval.
	30 ParaStatus Num	Displays the number of transmitted data.
	31 Para Status-1	Set address 1 for storing the transmitted data.
	32 Para Status-2	Set address 2 for storing the transmitted data.
	33 Para Status-3	Set address 3 for storing the transmitted data.
	34 Para Status-4	Set address 4 for storing the transmitted data.
	35 Para Status-5	Set address 5 for storing the transmitted data.
	36 Para Status-6	Set address 6 for storing the transmitted data.
	37 Para Status-7	Set address 7 for storing the transmitted data.
	38 Para Status-8	Set address 8 for storing the transmitted data.
	50 Para Ctrl Num	Displays the number of received data.
	51 Para Control-1	Set address 1 for storing the received data.
	52 Para Control-2	Set address 2 for storing the received data.
	53 Para Control-3	Set address 3 for storing the received data.
	54 Para Control-4	Set address 4 for storing the received data.
	55 Para Control-5	Set address 5 for storing the received data.

Code	Parameter name	Description
	56 Para Control-6	Set address 6 for storing the received data.
	57 Para Control-7	Set address 7 for storing the received data.
	58 Para Control-8	Set address 8 for storing the received data.
	84 BAC Dev Inst1	Enter decimal numbers greater than or equal to 1000 for the BACnet Device Instance.
	85 BAC Dev Inst2	Enter decimal numbers between 0 and 999 of the BACnet Device Instance.
	86 BAC PassWord	Enter the password for the BACnet password.
	94 Comm Update	Reflect the network parameter changes.
PRT	12 Lost Cmd Mode	Select operation mode for a lost command.
	13 Lost Cmd Time	Set the decision time for a lost command.
	14 Lost Preset F	Set the start frequency for a lost command.

10.2 CNF group

① [CNF-30] Option-1 Type: Displays the option slot 1 type

Automatically displays the type of communication module currently installed in the H100 inverter. “BACnet IP” is automatically displayed when the H100 Ethernet communication module has been installed in the H100 inverter.

** Depending on the inverter version, “Reserved-19” may be displayed instead of “BACnet IP.”

10.3 DRV group

① [DRV-06] Cmd Source: Command source

Select the command source for the H100 inverter. Set to “4 (Field Bus)” to set the Ethernet communication module as the command source and provide commands via network.

② [DRV-07] Freq Ref Src: Frequency reference source

Select the frequency command source for the H100 inverter. Set to “7 (Field Bus)” to set the Ethernet communication module as the frequency command source and provide frequency commands via network.

10.4 COM group

① [COM-06] FBus S/W Ver: Communication module S/W version

Automatically indicates the version of the communication module installed to the H100 inverter.

② [COM-07] FBus ID: Station ID of the communication module (communication module ID)

R: Set the station ID for the H100 Ethernet communication module. A total of 221 stations are available from “0” to “220.”

When setting the station ID, be careful not to use a station ID that has already been occupied by the PLC system or other network devices. After making setting changes, you must set COM-94 (Comm Update) to “1 (Yes)” before the changes can take effect.

③ [COM-09] FBus Led: Information about the LED indicators on the

communication module

Displays on the Keypad the status of the LED indicators on the H100 Ethernet communication module. Refer to “11.5 LED indications and troubleshooting” for the operation based on the indicator status.

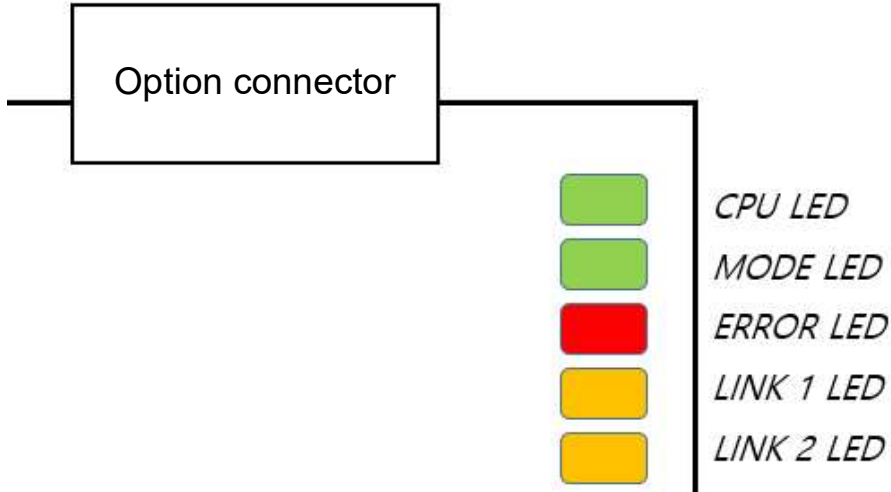

Example of the COM-09 (FBus LED) indication

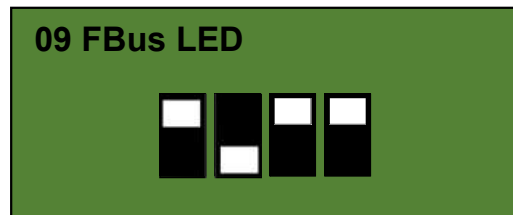

CPU	ERROR	LINK1	LINK2
LED ON	LED OFF	LED ON	LED ON

① **[COM-10] Opt Parameter -1: Operation of the DHCP server for the network**

H100 Ethernet communication module allows for dynamic allocation of network IP settings. This feature requires a router that is capable of performing dynamic IP allocation on the network.

② **[COM-11] Opt Parameter -2 : Ethernet Port 1, Port2**

Sets the operation status for the Ethernet Port 1 and Port 2 switches.

The 4 bits in the front (Hi bits) are used to set Port 1 and the 4 bits in the back (Lo bits) are used to set Port 2.

Switch Mode	Port1 (Hi 4bit)	Port2 (Lo 4bit)
AN enable	<input type="checkbox"/> <input type="checkbox"/> <input type="checkbox"/> <input type="checkbox"/>	<input type="checkbox"/> <input type="checkbox"/> <input type="checkbox"/> <input type="checkbox"/>
AN disable 100 Mbps, FULL	<input type="checkbox"/> <input type="checkbox"/> <input type="checkbox"/> <input type="checkbox"/>	<input type="checkbox"/> <input type="checkbox"/> <input type="checkbox"/> <input type="checkbox"/>
AN disable 100 Mbps, HALF	<input type="checkbox"/> <input type="checkbox"/> <input type="checkbox"/> <input type="checkbox"/>	<input type="checkbox"/> <input type="checkbox"/> <input type="checkbox"/> <input type="checkbox"/>
AN disable 10 Mbps , FULL	<input type="checkbox"/> <input type="checkbox"/> <input type="checkbox"/> <input type="checkbox"/>	<input type="checkbox"/> <input type="checkbox"/> <input type="checkbox"/> <input type="checkbox"/>
AN disable 10 Mbps , HALF	<input type="checkbox"/> <input type="checkbox"/> <input type="checkbox"/> <input type="checkbox"/>	<input type="checkbox"/> <input type="checkbox"/> <input type="checkbox"/> <input type="checkbox"/>

③ **[COM-21] Opt Parameter -12: Protocol options**

Sets the protocol for the H100 Ethernet communication module operation.

0: BACnet/IP , 1: Ethernet/IP , 2:Modbus TCP

④ **[COM-22] Opt Parameter -13 :Keep-Alive**

This parameter becomes available when [COM-21] (Opt Parameter-12) is set to “2: Modbus TCP.”

This parameter is set to “1: ON” by default. When it is enabled, the TCP Keep-Alive feature performs connection checks on Modbus TCP connections that have been dormant for a long period by sending messages. If the client is still connected, the connection will be maintained. However, if the client is not connected to the network anymore, it terminates the connection and retrieves the resources allocated to the connection.

* The client responds to this feature only when the TCP Keep-Alive feature is supported by the client.

When this feature is set to “0: OFF,” the connection will be maintained until it is terminated by the client and the resources available for network connections may become limited.

⑤ **[COM-23] Opt Parameter -14 : Keep-Alive Interval**

This parameter becomes available when [COM-21] (Opt Parameter-12) is set to “2: Modbus TCP.”

This feature is used when the TCP Keep-Alive feature has been enabled by setting [COM-22] (Opt Parameter-13) to “1: ON.” The Keep-alive Interval is set to decide the cycle time to check the connection of clients that have not

been active for a long period. The minimum interval is 10 sec.

⑥ **[COM-30] ParaStatus Num: Number of transmission data**

The H100 Ethernet communication module can transmit up to 8 data units. You can configure the address of the transmission data with parameters COM-31 through COM-38.

⑦ **[COM-31] Para Status1–[COM38] Para Status8: Transmission data address settings**

After setting the data transmission amount with COM-23, enter the matching number of data addresses for the data to transmit to the client (originator) with parameters COM-31 through COM-38.

This parameter becomes available only when the Ethernet/IP protocol is in use.

⑧ **[COM-50] Para Ctrl Num: Reception data amount**

The H100 Ethernet communication module can receive up to 8 data units. You can configure the address for the received data with parameters COM-51 through COM-58.

⑨ **[COM-51] Para Control 1–[COM58] Para Control 8: Reception data address settings**

After setting the number of reception data with COM-24, enter the matching number of data addresses for receiving command data from the client (originator) with parameters COM-51 through COM-58.

This parameter becomes available only when the Ethernet/IP protocol is in use.

⑩ **[COM-84] BAC Dev Inst 1: BACnet Device ID 1000 X N**

BACnet Device Instance is used to identify BACnet Device, and must be set as the unique value in the BACnet network. During installation, it helps you easily find BACnet devices among other types of devices.

The value set at COM-84 is used for the part of device instance value for the thousands or higher places. (BACnet Device ID = [COM-84 X 1000] + COM-85)

⑪ **[COM-85] BAC Dev Inst 2: BACnet Device ID 1 X N**

BACnet Device Instance is used to identify BACnet Device, and must be set as the unique value in the BACnet network. During installation, it helps you easily find BACnet devices among other types of devices.

The value set at COM-85 is used for the part of device instance value that is for the hundreds and lower places (BACnet Device ID = [COM-84 X 1000] + COM-85).

⑫ **[COM-86] BAC Password: BACnet feature**

Refers to the password used for Warm/Cold Start.

Warm/Cold Start services become available only when the password set at COM-86 matches the password set with the master device.

If COM-86 (Password) is set to "0," the password set with the BACnet master device is ignored and Warm/Cold Start services can be operated.

This password is required to access the Admin account of the web server.

⑬ **[COM-94] Comm Update: Update setting changes via the communication module**

The COM group parameters display the settings stored on the inverter connected to the Ethernet communication module and the changes made on the keypad are not directly reflected to the Ethernet communication module.

The changed settings will be reflected to the Ethernet communication module when you set COM-94 (Comm Update) to "1 (Yes)." (Parameters that require communication updates include COM-7 and COM 10 through COM-25.)

10.5 PRT group (Lost Command)

① [PRT-12] Lost Cmd Mode: Operation mode for a command loss

You can select the operation mode for when a network failure or connection failure between the H100 inverter and the communication module occurs while the inverter is operated via network communication.

② [PRT-13] Lost Cmd Time: Decision time for a command loss

Set the time duration until the operation mode set with PRT-12 will be reflected following a command loss. You can set a value between "0.1" and "120" seconds.

③ [PRT-14] Lost Preset F: Operation frequency reference configuration for a command loss

When a lost command occurs, a protective function is activated and the inverter continues to operate using the frequency set with PRT-14. The setting value is from the start frequency to the max frequency [Hz].

④ Lost command conditions by protocol

- BACnet/IP

If the BACnet/IP receives no data from the client for 1 sec, the Ethernet communication module enters the Lost Command status. After the time set at PRT-13 has elapsed, the inverter is operated according to the conditions set at PRT-12.

- EtherNet/IP

If the implicit message connection (Class1 Connection) between the originator (PLC or client) and the target (inverter) breaks for longer than the duration that is equivalent to "(Requested Packet Interval) x (Connection Timeout Multiplier) seconds," the Ethernet communication module enters the Lost Command status. After the time set at PRT-13 has elapsed, the inverter is operated according to the conditions set at PRT-12.

- Modbus TCP

If the Modbus TCP receives no data from the client for 1 sec, the Ethernet communication module enters the Lost Command status. After the time set at PRT-13 has elapsed, the inverter is operated according to the conditions set at PRT-12.

11 Services for the LS ELECTRIC products or other manufacturer's products

11.1 Overview

This chapter explains the services using BACnet/IP, EtherNet/IP, and Modbus/TCP protocols when LS ELECTRIC products or other manufacturer's products are connected to the network.

11.2 BACnet/IP

11.2.1 What is BACnet communication?

BACnet (Building Automation and Control network) is a communication network frequently used in building automation.

BACnet introduces the concept of object-oriented systems to achieve enhanced system flexibility. By exchanging data, this function makes communication possible between products from different companies. It also standardizes some of the general services carried out by using these standard objects.

11.2.2 BACnet Communication Standards

Connection	Interface	RJ45 Ethernet connector
	Cable	Twisted pair (shield)
Communication	BACnet IP	Stated in ANSI/ASHRAE Standards 135-2016

11.2.3 BACnet Quick Communication Start

Follow the instructions below to configure the BACnet network for a quick start.

- Check if the COM-21 (Opt Parameter-12) parameter has been set to "0: BACnet."
- Set a value for COM-84 (BAC Dev inst1). (Value for the thousands and higher places.)
- Set a value for COM-85 (BAC Dev inst2). You must set a unique value for the Device Object Instance.
- **Test the network and make sure the BACnet communication is working properly.**

Group	Code	Name	LCD Display	Parameter Setting	Setting Range	Unit		
COM	10	DHCP	Opt Parameter 1	0: static	0	Static		
					1	DHCP		
	11	Auto negotiation	Opt Parameter 2	■■■■■■■		Port1 (Hi4bit)	Port2 (Lo4bit)	-
					AN enable	■■■■	■■■■	
					AN disable 100 Mbps, FULL	■■■■	■■■■	
					AN disable 100 Mbps, HALF	■■■■	■■■■	
					AN disable 10 Mbps, FULL	■■■■	■■■■	
					AN disable 10 Mbps, HALF	■■■■	■■■■	
	12	IP address A	Opt Parameter 3	192	0 - 255			
	13	IP address B	Opt Parameter 4	168	0 - 255			
14	IP address C	Opt Parameter 5	1	0 - 255				
15	IP address	Opt Parameter 6	10	0 - 255				

Group	Code	Name	LCD Display	Parameter Setting	Setting Range	Unit
		D				
	16	Subnet mask	Opt Parameter 7	24	1 - 32	CIDR
	17	GW address A	Opt Parameter 8	192	0 - 255	
	18	GW address B	Opt Parameter 9	168	0 - 255	
	19	GW address C	Opt Parameter 10	1	0 - 255	
	20	GW address D	Opt Parameter 11	1	0 - 255	
	21	Option type	Opt Parameter 12	0	0: BACnet IP 1: Ethernet IP 2: MODBUS TCP	
	84	BACnet device number 1	BAC Dev Inst1	237	0 - 4149	-
	85	BACnet device number 2	BAC Dev Inst2	0	0 - 999	-
	86	BACnet device password	BAC PassWord	0	0 - 65535	-

* When you run the COMM update feature after changing the IP or option type setting, the system will automatically restart.

BACnet Parameter Setting Details

Code	Description
COM-84 & 85	BACnet Device Instance is used to identify BACnet Device, and

Code	Description
BAC Dev Inst 1 & 2	<p>must be set as the unique value in the BACnet network. During installation, it helps you easily find BACnet devices among other types of devices.</p> <p>The following formula is used to calculate the Device Instance value: (COM-84 X 1000) + COM-85 Therefore, in the Device Instance value, COM-84 takes the thousands or higher places (fourth digit and over) and COM-85 takes the hundreds or lower places (third digit and below).</p> <p>COM-84 and COM-85 have the ranges of 0–4194 and 0–999 respectively, because Device Instance can have the value within 0–4,194,302.</p>
COM-86 BAC Password	<p>Refers to the password used for Warm/Cold Start. Parameter COM-86 (Password) can be set within 0–65535, and the default value is 0. If the parameter setting range is set to 1–65535, the Password value set with the BACnet master device and the value set at COM-86 must match the operate Warm/Cold Start services.</p> <p>If COM-86 (Password) is set to "0," the password set with the BACnet master device is ignored and Warm/Cold Start services can be operated.</p>

11.2.4 Protocol Implement

(1) Services provided by the H100 BACnet protocol

- ✓ I-Am (Answer to Who-Is, when broadcast or reset after power-up)
- ✓ I-Have (Answer to Who-Has)
- ✓ ReadProperty
- ✓ WriteProperty
- ✓ DeviceCommunicationControl
 - DeviceCommunicationControl (supports passwords)
- ✓ ReinitializeDevice
 - Supports Warm/Cold Start (supports passwords)
 - Start Backup, End Backup, Start Restore, End Restore, and Abort Restore services are not available.

(2) Data Link Layer

- ✓ The BACnet communication module supports the BIP Data Link Layer.

(3) Device Object Instance

The Device Object Instance is set at COM-84 and COM-85.

11.2.5 Object Map

Property	Object Type						
	Device	BI	BV	AI	AV	MSI	MSV
Object Identifier	○	○	○	○	○	○	○
Object Name	○	○	○	○	○	○	○
Object Type	○	○	○	○	○	○	○
System Status	○						
Vendor Name	○						
Vendor Identifier	○						
Model Name	○						
Firmware Revision	○						
Appl Software Revision	○						
Location	○						
Protocol Version	○						
Protocol Revision	○						
Services Supported	○						
Object Types Supported	○						
Object List	○						

Max APDU Length	O						
APDU Timeout	O						
Number APDU Retries	O						
Max Info Frames	O						
Device Address Binding	O						
Database Revision	O						
Preset Value		O	O	O	O	O	O
Description	O	O	O	O	O	O	O
Status Flags		O	O	O	O	O	O
Reliability		O	O	O	O	O	O
Out-of-Service		O	O	O	O	O	O
Number of states						O	O
State text						O	O
Units				O	O		
Polarity		O					
Active Text		O	O				

- BI – Binary Input
- BV – Binary Value
- AI – Analog Input
- AV – Analog Value
- MSI – Multistate Input
- MSV – Multistate Value

You can read/write in Location and Description only if it is the device object. You can write a maximum of 29 words.

11.2.5.1 Analog Value Object Instance

Instance ID	Object Name	Description	Range (REAL)	Units	R/W
AV1	CommTimeoutSet	Command timeout setting	0.1 - 120.0	Secs	R/W
AV2	AccelTimeSet	ACC time setting*	0.0 - 600.0	Secs	R/W
AV3	DecelTimeSet	DEC time setting*	0.0 - 600.0	Secs	R/W
AV4	CommandFreqSet	Command frequency	0.00 - DRV-20	Hz	R/W

		setting**			
AV5	PIDReferenceSet	PID Reference Set	0 - 100.0	%	R/W
AV6	PIDFeedbackSet	PID Feedback Set	0 - 100.0	%	R/W

ⓘ Caution

- When PowerOn Resume (COM-96) is set to "Yes," values are saved even if the power is disconnected from the inverter. If PowerOn Resume (COM-96) is set to "No," values are not saved when the power is disconnected from the inverter.
- You cannot set the value higher than the maximum frequency (DRV-20). The maximum frequency can be set by using the keypad. This value can be used when Freq Ref Src (DRV-07) is set to "FieldBus." When PowerOn Resume (COM-96) is set to "Yes," values are saved even if the power is disconnected from the inverter. If PowerOn Resume (COM-96) is set to "No," values are not saved when the power is disconnected from the inverter.
- AV2, AV3 and AV4 are used to provide acceleration/deceleration and frequency references. These can be written in AUTO mode only.

11.2.5.2 MultiState Value Object Instance

Instance ID	Object Name	Description	Range Enumeration	Units	R/W
MSV1	LostCommand	Command lost operation setting	0: None 1: FreeRun 2: Dec 3: HoldInput 4: HoldOutput 5: LostPreset	MSG	R/W

11.2.5.3 Binary Value Object Instance

Instance ID	Object Name	Description	Active / Inactive Text Boolean	R/W
BV1	StopCmd	Stop command	False/True	R/W
BV2	RunForwardCmd	Run forward command	False/True	R/W
BV3	RunReverseCmd	Reverse run command	False/True	R/W
BV4	ResetFaultCmd	Fault reset command	False/True	R/W
BV5	FreeRunStopCmd	Free-run stop command	False/True	R/W
BV6	Relay1Cmd	Relay 1 On/Off command	False/True	R/W
BV7	Relay2Cmd	Relay 2 On/Off command	False/True	R/W
BV8	Relay3Cmd	Relay 3 On/Off command	False/True	R/W
BV9	Relay4Cmd	Relay 4 On/Off command	False/True	R/W
BV10	Relay5Cmd	Relay 5 On/Off command	False/True	R/W
BV11	Q1Cmd	Q1 On/Off command	False/True	R/W

11.2.5.4 Analog Input Object Instance

Instance ID	Object Name	Description	Units REAL	R/W
AI1	InvCap (kW)	Inverter capacity (kW)	kW	R
AI2	InvCap(HP)	Inverter capacity (HP)	HP	R
AI3	InvVoltageClass	Inverter voltage type	Volts	R
AI4	OutputCurrent	Output current	Amps	R

AI5	OutputFreq	Output frequency	Hz	R
AI6	OutputVolgate	Output voltage	Volts	R
AI7	DCLinkVoltage	DC Link voltage	Volts	R
AI8	OutputPower	Output power	kW	R
AI9	AI1	Analog 1 value	%	R
AI10	AI2	Analog 2 value	%	R
AI11	OutputRPM	Output speed	RPM	R
AI12	Pole	Number of motor poles	-	R
AI13	InvStatus	Information of the inverter state (Refer to the common area parameter address 0h0305) (Note 1)	-	R
AI14	LatchTripInfo1	Latch type fault trip information 1 (Refer to the common area parameter address 0h0330) (Note 1)	-	R
AI15	LatchTripInfo2	Latch type fault trip information 2 (Refer to the common area parameter address 0h0331) (Note 1)	-	R
AI16	LatchTripInfo3	Latch type fault trip information 3 (Refer to the common area parameter address 0h0335) (Note 1)	-	R
AI17	LevelTripInfo	Level type trip information (Refer to the common area parameter address 0h0332) (Note 1)	-	R
AI18	HWDIagInfo	H/W Diagnosis fault trip information (Refer to the common area parameter address 0h0333) (Note 1)	-	R
AI19	WarningInfo	Warning information (Refer to the common area parameter address 0h0334) (Note 1)	-	R

AI20	KiloWattHour	Output power (kW/h)	KW/h	R
AI21	MegaWattHour	Output power (MW/h)	MW/h	R
AI22	PowerFactor	Power factor	-	R
AI23	RunTimeDay	Operation time (Day)	Day	R
AI24	RunTimeMin	Operation time (Min)	Day	R
AI25	PidOutValue	PID Output Value	%	R
AI26	PidReferenceValue	PID Reference Value	%	R
AI27	PidFeedbackValue	PID Feedback Value	%	R

(Note 1): Refer to the relevant addresses listed in “7.3.8 Compatible Common Area Parameter” of H100 User Manual.

11.2.5.5 Binary Input Object Instance

Instance ID	Object Name	Description	R/W
BI1	Stopped	Stop state	R
BI2	RunningForward	Running forward	R
BI3	RunningReverse	Running reverse	R
BI4	Tripped	Trip occurred	R
BI5	Accelerating	Accelerating	R
BI6	Decelerating	Decelerating	R
BI7	SteadySpeed	Operating at a steady speed	R
BI8	RunningDC	Operating at a 0 step speed	R
BI9	Stopping	Stopping	R
BI10	FwdRunCommandState	Forward run command state	R
BI11	RevRunCommandState	Reverse run command state	R
BI12	P1	P1 state	R
BI13	P2	P2 state	R
BI14	P3	P3 state	R
BI15	P4	P4 state	R

BI16	P5	P5 state	R
BI17	P6	P6 state	R
BI18	P7	P7 state	R
BI19	Relay1	Relay1 state*	R
BI20	Relay2	Relay2 state*	R
BI21	Relay3	Relay3 state*	R
BI22	Relay4	Relay4 state*	R
BI23	Relay5	Relay5 state*	R
BI24	Q1	Q1 state	R
BI25	SpeedSearch	Speed search operation in progress	R
BI26	HWOCS	H/W OCS occurred	R
BI27	SWOCS	S/W OCS occurred	R
BI28	RunningDwell	Dwell operation status	R
BI29	SteadyState	Steady state	R
BI30	Warning	Warning state	R

ⓘ Caution

- OUT-31 – 35 (Relay 1 – 5) must be set to "0 (none)" to control outputs via network communication.

11.2.5.6 MultiState Input Object Instance

Instance ID	Object Name	Description	Units Enumeration	R/W
MSI1	UnitsDisplay	Displays unit settings	1 Hz 2 RPM	R

11.2.5.7 Error Message

Display	Description
serviceserror+7	inconsistentparameters
propertyerror+9	Invalid Data Type
serviceserror+10	invalidaccessmethod
serviceserror+11	invalidfilestart
serviceserror+29	servicerequestdenied
objecterror+31	unknownobject
propertyerror+0	propertyother
propertyerror+27	readaccessdenied
propertyerror+32	unknownproperty
propertyerror+37	valueoutofrange
propertyerror+40	writeaccessdenied
propertyerror+42	invalidarrayindex
clienterror+31	unknowndevice
resourceserror+0	resourcesother
clienterror+30	timeout
abortreason+4	segmentationnotsupported
rejectreason+4	invalidtag
clienterror+0xFF	noinvokeid
securityerror+26	passwordfailure

11.3 EtherNet/IP

11.3.1 Basic protocol structure

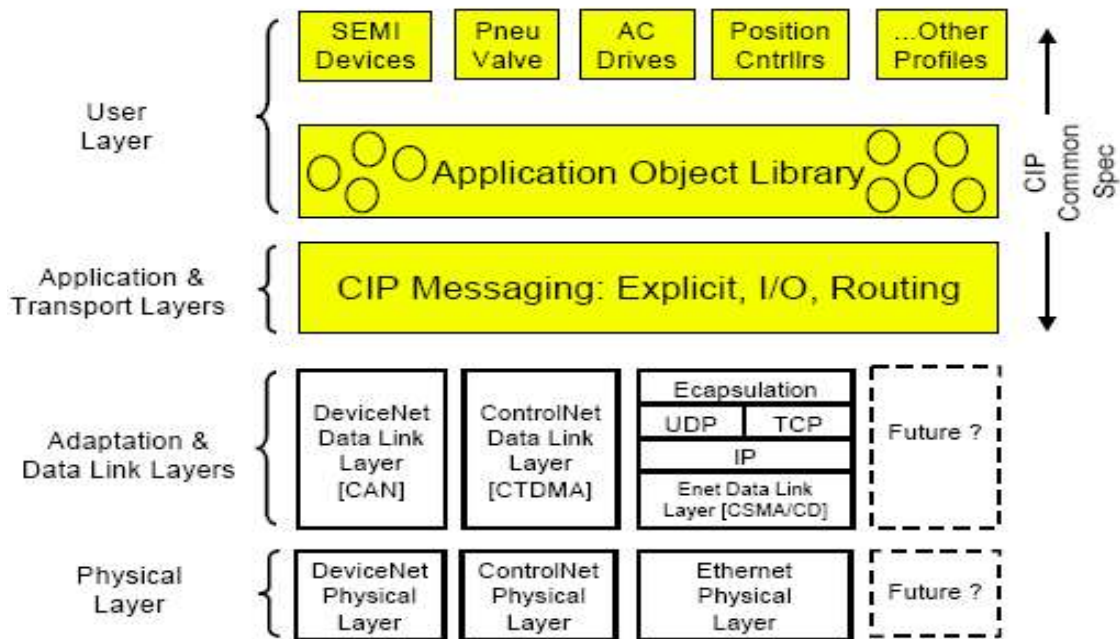

The EtherNet/IP is a protocol which implements the CIP (Common Industrial Protocol, specified by the ODVA) using the TCP and UDP protocols.

Originator: Devices that make connection requests, which are also called clients.

PLCs or scanners are examples of originators.

Target: Devices that respond to connection requests, which are also called servers.

Inverters are examples of targets.

11.3.2 Implicit Message

Implicit messages are also called I/O messages. It refers to the data communicated between the client (originator) and the server (target) at predefined intervals, via input and output instances.

The class 1 connection is used for implicit messages.

① **Scope of support**

Transport Type

Originator->Target: Point to Point

Target->Originator: Multicast

Transport Trigger: Cyclic

Configuration Connection: 1

Connection Tag: Not available

Priority

Originator->Target: Scheduled

Target->Originator: Scheduled

Configuration Data: Not available

② **Input Instance**

Input instances refer to the status data periodically sent from the inverter to PLCs or other client devices.

Instance	Byte	Bit 7	Bit 6	Bit 5	Bit 4	Bit 3	Bit 2	Bit 1	Bit 0
70	0						Running 1 (Fwd)		Faulted
	1								
	2	Speed Actual (Low Byte) – RPM unit (note 1)							
	3	Speed Actual (High Byte) – RPM unit							
71	0	At Referen ce	Ref From Net	Ctrl From Net	Ready	Running 2 (Rev)	Running 1 (Fwd)	Warnin g	Faulted
	1	Drive State							
	2	Speed Actual (Low Byte) – RPM unit							
	3	Speed Actual (High Byte) – RPM unit							
110	0						Running 1 (Fwd)		Faulted
	1								

Instance	Byte	Bit 7	Bit 6	Bit 5	Bit 4	Bit 3	Bit 2	Bit 1	Bit 0
	2	Speed Actual (Low Byte) – Hz unit (note 1)							
	3	Speed Actual (High Byte) – Hz unit							
111	0	At Reference	Ref From Net	Ctrl From Net	Ready	Running 2 (Rev)	Running 1 (Fwd)	Warning	Faulted
	1	Drive State							
	2	Speed Actual (Low Byte) – Hz unit							
	3	Speed Actual (High Byte) – Hz unit							
	141 ^{Note 1)}	0	COM-31 Status Parameter - 1 data (Low Byte)						
	1	COM-31 Status Parameter - 1 data (Hi Byte)							
142 ^{Note 1)}	0	COM-31 Status Parameter - 1 data (Low Byte)							
	1	COM-31 Status Parameter - 1 data (Hi Byte)							
	2	COM-32 Status Parameter - 2 data (Low Byte)							
	3	COM-32 Status Parameter - 2 data (Hi Byte)							
143 ^{Note 1)}	0	COM-31 Status Parameter - 1 data (Low Byte)							
	1	COM-31 Status Parameter - 1 data (Hi Byte)							
	2	COM-32 Status Parameter - 2 data (Low Byte)							
	3	COM-32 Status Parameter - 2 data (Hi Byte)							
	4	COM-33 Status Parameter - 3 data (Low Byte)							
	5	COM-33 Status Parameter - 3 data (Hi Byte)							
144 ^{Note 1)}	0	COM-31 Status Parameter - 1 data (Low Byte)							
	1	COM-31 Status Parameter - 1 data (Hi Byte)							
	2	COM-32 Status Parameter - 2 data (Low Byte)							
	3	COM-32 Status Parameter - 2 data (Hi Byte)							
	4	COM-33 Status Parameter - 3 data (Low Byte)							
	5	COM-33 Status Parameter - 3 data (Hi Byte)							
	6	COM-34 Status Parameter - 4 data (Low Byte)							
	7	COM-34 Status Parameter - 4 data (Hi Byte)							
145 ^{Note 1)}	0	COM-31 Status Parameter - 1 data (Low Byte)							
	1	COM-31 Status Parameter - 1 data (Hi Byte)							
	2	COM-32 Status Parameter - 2 data (Low Byte)							
	3	COM-32 Status Parameter - 2 data (Hi Byte)							
	4	COM-33 Status Parameter - 3 data (Low Byte)							
	5	COM-33 Status Parameter - 3 data (Hi Byte)							
	6	COM-34 Status Parameter - 4 data (Low Byte)							
	7	COM-34 Status Parameter - 4 data (Hi Byte)							
	8	COM-35 Status Parameter - 5 data (Low Byte)							

Instance	Byte	Bit 7	Bit 6	Bit 5	Bit 4	Bit 3	Bit 2	Bit 1	Bit 0
	9	COM-35 Status Parameter - 5 data (Hi Byte)							
146 <small>Note</small> 1)	0	COM-31 Status Parameter - 1 data (Low Byte)							
	1	COM-31 Status Parameter - 1 data (Hi Byte)							
	2	COM-32 Status Parameter - 2 data (Low Byte)							
	3	COM-32 Status Parameter - 2 data (Hi Byte)							
	4	COM-33 Status Parameter - 3 data (Low Byte)							
	5	COM-33 Status Parameter - 3 data (Hi Byte)							
	6	COM-34 Status Parameter - 4 data (Low Byte)							
	7	COM-34 Status Parameter - 4 data (Hi Byte)							
	8	COM-35 Status Parameter - 5 data (Low Byte)							
	9	COM-35 Status Parameter - 5 data (Hi Byte)							
	10	COM-36 Status Parameter - 6 data (Low Byte)							
	11	COM-36 Status Parameter - 6 data (Hi Byte)							
147 <small>Note</small> 1)	0	COM-31 Status Parameter - 1 data (Low Byte)							
	1	COM-31 Status Parameter - 1 data (Hi Byte)							
	2	COM-32 Status Parameter - 2 data (Low Byte)							
	3	COM-32 Status Parameter - 2 data (Hi Byte)							
	4	COM-33 Status Parameter - 3 data (Low Byte)							
	5	COM-33 Status Parameter - 3 data (Hi Byte)							
	6	COM-34 Status Parameter - 4 data (Low Byte)							
	7	COM-34 Status Parameter - 4 data (Hi Byte)							
	8	COM-35 Status Parameter - 5 data (Low Byte)							
	9	COM-35 Status Parameter - 5 data (Hi Byte)							
	10	COM-36 Status Parameter - 6 data (Low Byte)							
	11	COM-36 Status Parameter - 6 data (Hi Byte)							
	12	COM-37 Status Parameter - 7 data (Low Byte)							
	13	COM-37 Status Parameter - 7 data (Hi Byte)							
148 <small>Note</small> 1)	0	COM-31 Status Parameter - 1 data (Low Byte)							
	1	COM-31 Status Parameter - 1 data (Hi Byte)							
	2	COM-32 Status Parameter - 2 data (Low Byte)							
	3	COM-32 Status Parameter - 2 data (Hi Byte)							
	4	COM-33 Status Parameter - 3 data (Low Byte)							
	5	COM-33 Status Parameter - 3 data (Hi Byte)							
	6	COM-34 Status Parameter - 4 data (Low Byte)							
	7	COM-34 Status Parameter - 4 data (Hi Byte)							

Instance	Byte	Bit 7	Bit 6	Bit 5	Bit 4	Bit 3	Bit 2	Bit 1	Bit 0
	8	COM-35 Status Parameter - 5 data (Low Byte)							
	9	COM-35 Status Parameter - 5 data (Hi Byte)							
	10	COM-36 Status Parameter - 6 data (Low Byte)							
	11	COM-36 Status Parameter - 6 data (Hi Byte)							
	12	COM-37 Status Parameter - 7 data (Low Byte)							
	13	COM-37 Status Parameter - 7 data (Hi Byte)							
	14	COM-38 Status Parameter - 8 data (Low Byte)							
	15	COM-38 Status Parameter - 8 data (Hi Byte)							

Note 1) Refer to “⑦ [COM-31] Para Status 1–[COM38] Para Status8” in “10.4 COM group” of this manual to set the inverter target addresses.

The following table explains the data (Bytes 0 and 1) for instances 70, 71, 110, and 111.

Name	Description	Related Attribute	
		Class	Attr. ID
Faulted	Inverter Error	0x29	10
Warning	Not Supported	0x29	11
Running1	Motor is running Forward	0x29	7
Running2	Motor is running Reverse	0x29	8
Ready	Motor is ready to running	0x29	9
Ctrl From Net	Run/Stop control	0x29	15
Ref From Net	Speed control	0x2A	29
At Reference	Reach at reference Speed	0x2A	3
Drive State	Current Motor State	0x29	6
Speed Actual	Speed Command	0x2A	7

③ Output Instance

Output Instance refers to the status data periodically sent from a PLC or other client devices to the inverter.

Instance	Byte	Bit 7	Bit 6	Bit 5	Bit 4	Bit 3	Bit 2	Bit 1	Bit 0
20	0						Fault Reset		Run Fwd
	1	0							
	2	Speed Reference (Low Byte) – RPM unit							

Instance	Byte	Bit 7	Bit 6	Bit 5	Bit 4	Bit 3	Bit 2	Bit 1	Bit 0
	3	Speed Reference (High Byte) – RPM unit							
21	0		NetRef (note 2)	NetCtrl (note2)			Fault Reset	Run Rev	Run Fwd
	1	0							
	2	Speed Reference (Low Byte) – RPM unit							
	3	Speed Reference (High Byte) – RPM unit							
100	0						Fault Reset		Run Fwd
	1	0							
	2	Speed Reference (Low Byte) – Hz unit							
	3	Speed Reference (High Byte) – Hz unit							
101	0		NetRef	NetCtrl			Fault Reset	Run Rev	Run Fwd
	1	0							
	2	Speed Reference (Low Byte) – Hz unit							
	3	Speed Reference (High Byte) – Hz unit							
121 Note2)	0	COM-51 Control Parameter - 1 data (Low Byte)							
	1	COM-51 Control Parameter - 1 data (Hi Byte)							
122 Note2)	0	COM-51 Control Parameter - 1 data (Low Byte)							
	1	COM-51 Control Parameter - 1 data (Hi Byte)							
	2	COM-52 Control Parameter - 2 data (Low Byte)							
	3	COM-52 Control Parameter - 2 data (Hi Byte)							
123 Note 2)	0	COM-51 Control Parameter - 1 data (Low Byte)							
	1	COM-51 Control Parameter - 1 data (Hi Byte)							
	2	COM-52 Control Parameter - 2 data (Low Byte)							
	3	COM-52 Control Parameter - 2 data (Hi Byte)							
	4	COM-53 Control Parameter - 3 data (Low Byte)							
	5	COM-53 Control Parameter - 3 data (Hi Byte)							
124 Note 2)	0	COM-51 Control Parameter - 1 data (Low Byte)							
	1	COM-51 Control Parameter - 1 data (Hi Byte)							
	2	COM-52 Control Parameter - 2 data (Low Byte)							
	3	COM-52 Control Parameter - 2 data (Hi Byte)							
	4	COM-53 Control Parameter - 3 data (Low Byte)							
	5	COM-53 Control Parameter - 3 data (Hi Byte)							
	6	COM-54 Control Parameter - 4 data (Low Byte)							
	7	COM-54 Control Parameter - 4 data (Hi Byte)							
125 Note	0	COM-51 Control Parameter - 1 data (Low Byte)							

Instance	Byte	Bit 7	Bit 6	Bit 5	Bit 4	Bit 3	Bit 2	Bit 1	Bit 0
2)	1	COM-51 Control Parameter - 1 data (Hi Byte)							
	2	COM-52 Control Parameter - 2 data (Low Byte)							
	3	COM-52 Control Parameter - 2 data (Hi Byte)							
	4	COM-53 Control Parameter - 3 data (Low Byte)							
	5	COM-53 Control Parameter - 3 data (Hi Byte)							
	6	COM-54 Control Parameter - 4 data (Low Byte)							
	7	COM-54 Control Parameter - 4 data (Hi Byte)							
	8	COM-55 Control Parameter - 5 data (Low Byte)							
	9	COM-55 Control Parameter - 5 data (Hi Byte)							
126 Note 2)	0	COM-51 Control Parameter - 1 data (Low Byte)							
	1	COM-51 Control Parameter - 1 data (Hi Byte)							
	2	COM-52 Control Parameter - 2 data (Low Byte)							
	3	COM-52 Control Parameter - 2 data (Hi Byte)							
	4	COM-53 Control Parameter - 3 data (Low Byte)							
	5	COM-53 Control Parameter - 3 data (Hi Byte)							
	6	COM-54 Control Parameter - 4 data (Low Byte)							
	7	COM-54 Control Parameter - 4 data (Hi Byte)							
	8	COM-55 Control Parameter - 5 data (Low Byte)							
	9	COM-55 Control Parameter - 5 data (Hi Byte)							
	10	COM-56 Control Parameter - 6 data (Low Byte)							
	11	COM-56 Control Parameter - 6 data (Hi Byte)							
127 Note 2)	0	COM-51 Control Parameter - 1 data (Low Byte)							
	1	COM-51 Control Parameter - 1 data (Hi Byte)							
	2	COM-52 Control Parameter - 2 data (Low Byte)							
	3	COM-52 Control Parameter - 2 data (Hi Byte)							
	4	COM-53 Control Parameter - 3 data (Low Byte)							
	5	COM-53 Control Parameter - 3 data (Hi Byte)							
	6	COM-54 Control Parameter - 4 data (Low Byte)							
	7	COM-54 Control Parameter - 4 data (Hi Byte)							
	8	COM-55 Control Parameter - 5 data (Low Byte)							
	9	COM-55 Control Parameter - 5 data (Hi Byte)							
	10	COM-56 Control Parameter - 6 data (Low Byte)							
	11	COM-56 Control Parameter - 6 data (Hi Byte)							
	12	COM-57 Control Parameter - 7 data (Low Byte)							
	13	COM-57 Control Parameter - 7 data (Hi Byte)							
128 Note	0	COM-51 Control Parameter - 1 data (Low Byte)							

Instance	Byte	Bit 7	Bit 6	Bit 5	Bit 4	Bit 3	Bit 2	Bit 1	Bit 0
2)	1	COM-51 Control Parameter - 1 data (Hi Byte)							
	2	COM-52 Control Parameter - 2 data (Low Byte)							
	3	COM-52 Control Parameter - 2 data (Hi Byte)							
	4	COM-53 Control Parameter - 3 data (Low Byte)							
	5	COM-53 Control Parameter - 3 data (Hi Byte)							
	6	COM-54 Control Parameter - 4 data (Low Byte)							
	7	COM-54 Control Parameter - 4 data (Hi Byte)							
	8	COM-55 Control Parameter - 5 data (Low Byte)							
	9	COM-55 Control Parameter - 5 data (Hi Byte)							
	10	COM-56 Control Parameter - 6 data (Low Byte)							
	11	COM-56 Control Parameter - 6 data (Hi Byte)							
	12	COM-57 Control Parameter - 7 data (Low Byte)							
	13	COM-57 Control Parameter - 7 data (Hi Byte)							
	14	COM-58 Control Parameter - 8 data (Low Byte)							
	15	COM-58 Control Parameter - 8 data (Hi Byte)							

(Note 2) Refer to “⑨ [COM-51] Para Control1–[COM58] Para Control 8” in “10.4 COM group” of this manual to set the inverter target addresses.

The following table explains the data (bits for Byte 0) for instances 20, 21, 100, and 101.

Name	Description	Related Attribute	
		Class	Attr. ID
Run Fwd (Note 3)	Forward Run Command	0x29	3
Run Rev (Note 3)	Reverse Run Command	0x29	4
Fault reset (Note 3)	Fault Reset Command	0x29	12
NetRef (Note 4)	Not used	0x2A	4
NetCtrl (Note 4)	Not used	0x29	5
Speed Reference	Speed Command	0x2A	8

(Note 3) Refer to the Drive Run and Fault sections in the “Control Supervisor Object (Class 0x29).”

(Note 4) Reference speed and Run/Stop control can be set only on the LCD control panel. Network control instances 21 and 101 (NetRef, NetCtrl) are not available.

11.3.3 Explicit Message

Explicit messages refer to non-periodic data communications used for reading or writing attribute values of an inverter or an Ethernet IP.

Using the UCMM communication, data exchange is made without connecting the originator and the target, and periodic data exchange is available as well using the Class 3 connection.

11.3.4 Supported objects

① Identity Object (Class 0x01, Instance 1)

Attribute

Attribute ID	Access	Attribute Name	Data Length	Attribute Value
1	Get	Vendor ID	Word	259
2	Get	Device Type (AC Drive)	Word	2
3	Get	Product Code	Word	15 (Note 1)
4	Get	Revision High Byte - Major Revision Low Byte - Minor Revision	Word	(Note 2) 0x0101
5	Get	Status	Word	(Note 3)
6	Get	Serial Number	Double Word	(Note 4)
7	Get	Product Name	9 Bytes	CBAC-H100

(Note 1) Product Code 15 refers to the H100 Ethernet inverter product (Model type: F).

(Note 2) The revision refers to the version of the Ethernet/IP protocol. The high byte stands for a major revision number, and the low byte stands for a minor revision number. For example, 0x0101 indicates version 1.01.

This value is different from the OS version of the communication module (which is available on the Keypad with the COM-6 [FBus S/W Ver] parameter).

(Note 3) Definition of status bits

Bit	Description
0	0: Device is not connected to the master 1: Device is connected to the master
1	Reserved
2	Configured (fixed as "1" because LS ELECTRIC EtherNet/IP is not supported)
3	Reserved
4	0 : Unknown
5	2: Faulty IO connection
6	3: IO connection has not been made
7	5 : Major Fault
7	6: IO connection has been made
8	Minor recoverable fault (Inverter is in warning status)

Bit	Description
9	Minor unrecoverable fault (N/A)
10	Major recoverable fault (inverter H/W trip occurred)
11	Major recoverable fault (inverter non-H/W trip occurred)

(Note 4) The serial number uses the last four digits of the MAC ID.

e.g.) The serial number is 0x29000022 when the MAC ID is "00:0B:29:00:00:22."

Service

Service Code	Definition	Support for Class	Support for Instance
0x0E	Get Attribute Single	No	Yes
0x05	Reset	No	Yes
0x01	Get Attribute All	No	Yes

② Motor Data Object (Class 0x28, Instance 1)

Attribute

Attribute ID	Access	Attribute Name	Range	Definition
3	Get	Motor Type	0 - 10	0 : Non-standard motor 1 : PM DC Motor 2 : FC DC Motor 3 : PM Synchronous Motor 4 : FC Synchronous Motor 5 : Switched Reluctance Motor 6 : Wound Rotor Induction Motor 7 : Squirrel Cage Induction Motor 8 : Stepper Motor 9 : Sinusoidal PM BL Motor 10 : Trapezoidal PM BL Motor
6	Get/Set	Motor Rated Curr	0.0 - 1000.0	[Get] Reads the value at BAS-13 (Rated Curr). [Set] The set value is reflected to BAS-13 (Rated Curr). Scale 0.1
7	Get/Set	Motor Rated	0 -	[Get]

Attribute ID	Access	Attribute Name	Range	Definition
		Volt	690	Reads the value at BAS-15 Rated Voltage. [Set] The set value is reflected to BAS-15 (Rated Voltage). Scale 1

Service

Service Code	Definition	Support for Class	Support for Instance
0x0E	Get Attribute Single	No	Yes
0x10	Set Attribute Single	No	Yes

③ Control Supervisor Object (Class 0x29, Instance 1)
Attribute

Attribute ID	Access	Attribute Name	Range	Definition
3	Get / Set	Forward Run Cmd.	0	Stopped
			1	Forward run (Note 1)
4	Get / Set	Reverse Run Cmd.	0	Stopped
			1	Reverse run (Note 1)
5	N/A	Net Control	-	Configurable only with the inverter parameter.
6	Get	Drive State	0	Vendor Specific
			1	Startup
			2	Not Ready (resetting in progress)
			3	Ready (stopping in progress)
			4	Enabled (running, not applicable to deceleration stop)
			5	Stopping (decelerating)
			6	Fault Stop
			7	Faulted (trip occurred)
7	Get	Running Forward	0	Stopping in progress
			1	Running Forward
8	Get	Running Reverse	0	Stopping in progress
			1	Running Reverse
9	Get	Drive Ready	0	Resetting in progress or trip occurred
			1	Inverter is ready for operation
10	Get	Drive Fault	0	Trip has not occurred
			1	Trip has occurred

Attribute ID	Access	Attribute Name	Range	Definition
12	Get / Set	Drive Fault Reset	0	Trip reset to release the trip. Resetting will begin only when the value changes from FALSE to TRUE. (Note 2)
			1	
13	Get	Drive Fault Code		Refer to the following Drive Fault Code table (Note 2)
15	Get	Control From Net.	0	Commands are made using other sources than the Ethernet communication.
			1	Commands are made using the Ethernet communication as the source.

(Note 1) Drive Run Command
Inverter operation using Forward Run Cmd. and Reverse Run Cmd.

Run1	Run2	Trigger Event	Run Type
0	0	Stop	NA
0 → 1	0	Run	Run1
0	0 → 1	Run	Run2
0 → 1	0 → 1	No Action	NA
1	1	No Action	NA
1 → 0	1	Run	Run2
1	1 → 0	Run	Run1

In the table above, Run 1 indicates Forward Run Cmd. and Run 2 indicates Reverse Run Cmd. Commands are made by the Ethernet communication module when the value changes from "0 (FALSE)" to "1 (TRUE)." The Forward Run Cmd. value does not indicate the present operation status of the inverter; it indicates the operation command value on the communication module.

(Note 2) Drive Fault

The Drive Fault becomes TRUE when the inverter is tripped.
Drive Fault Codes for the trips are as follows.

Drive Fault Code

Fault Code Number	Description		
0x0000	None		
0x1000	Ethermal	Out Phase Open	InverterOLT
	InPhaseOpen	ThermalTrip	UnderLoad
	ParaWriteTrip	IOBoardTrip	PrePIDFail

Fault Code Number	Description		
	OptionTrip1	OptionTrip2	OptionTrip3
	LostCommand	UNDEFINED	LostKeypad
0x2200	OverLoad		
0x2310	OverCurrent1		
0x2330	GFT		
0x2340	OverCurrent2		
0x3210	OverVoltage		
0x3220	LowVoltage		
0x2330	GroundTrip		
0x4000	NTCOpen		
0x4200	OverHeat		
0x5000	FuseOpen		HWDiag
0x7000	FanTrip		
0x7120	No Motor Trip		
0x7300	EncorderTrip		
0x8401	SpeedDevTrip		
0x8402	OverSpeed		
0x9000	ExternalTrip		BX

Drive Fault Reset

The Drive Fault Reset gives TRIP RESET reference to the inverter when the setting value changes from “0” to “1” (from FALSE to TRUE). Overwriting “1 (TRUE)” over “1 (TRUE)” does not generate a RESET reference for a trip. To allow the Ethernet communication module to send a RESET reference to the inverter when the value is “1 (TRUE),” write “0 (FAULT)” first, then write “1(TRUE)” again.

Service

Service Code	Definition	Support for Class	Support for Instance
0x0E	Get Attribute Single	No	Yes
0x10	Set Attribute Single	No	Yes

④ AC Drive Object (Class 0x2A, Instance 1)

Attribute

Attribute ID	Access	Attribute Name	Range	Definition
3	Get	At Reference	0	The output frequency has not reached the reference frequency.
			1	The output frequency has reached the reference frequency.
4	N/A	Net Reference	-	
6	Get	Drive Mode (Note 1)	0	Vendor Specific Mode
			1	Open Loop Speed(Frequency)
			2	Closed Loop Speed Control
			3	Torque Control
			4	Process Control(e.g.PI)
7	Get	SpeedActual	0 - 24000	Displays the present output frequency in [rpm].
8	Get / Set	SpeedRef	0 - 24000	Displays the reference frequency in [RPM]. Reflected when DRV-07 (Freq Ref Src) is set to "FieldBus."
9	Get	Actual Current	0 - 111.0 A	Monitors the present current in 0.1 A increment/decrement.
29	Get	Ref.From Network	0	Command source is not the Ethernet communication.
			1	Command source is the Ethernet communication.
100	Get	Actual Hz	0 - 400.00 Hz	Monitors the present operation frequency (Hz).
101	Get / Set	Reference Hz	0 - 400.00 Hz	Speed reference may be given via a network communication if DRV-07 (Freq Ref Src) is set to 8 (FieldBus).
102	Get / Set	Acceleration Time (Note 2)	0 - 6000.0 sec	Sets/monitors the acceleration time of the inverter.
103	Get /Set	Deceleration Time (Note 3)	0 - 6000.0 sec	Sets/monitors the deceleration time of the inverter.

(Note 1) For the H100 inverter products, this value is fixed as "1: Open Loop Speed (Frequency)."

(Note 2) Value at DRV-03 (Acc Time)

(Note 3) Value at DRV-04 (Dec Time)

Service

Service Code	Definition	Support for Class	Support for Instance
0x0E	Get Attribute Single	No	Yes
0x10	Set Attribute Single	No	Yes

⑤ **DLR Object (Class 0x47, Instance 1)**

Attribute

Attribute ID	Access	Attribute Name	Range	Definition
1	Get	Network Topology	0	Linear Network
			1	Ring Network
2	Get	Network Status	0	Normal
			1	Ring Fault
10	Get	Active Supervisor Address		The IP and MAC address of the ring supervisor
12	Get	Capability Flags		Announce-based Ring Node

Service

Service Code	Definition	Support for Class	Support for Instance
0x0E	Get Attribute Single	No	Yes
0x10	Set Attribute Single	No	Yes

⑥ **Class 0x64 (Inverter Object) – Manufacture Profile**

This object is used to access the Keypad Parameters of the inverter.

Attribute

Instance	Access	Attribute Number	Attribute Name	Attribute Value
1 (DRV Group)	Get/Set	Identical to the H100 Manual Code number.	H100 Keypad Title (Refer to the H100 User Manual)	Parameter setting range for the H100 inverter (Refer to the H100 User Manual)
2 (BAS Group)		Identical to the H100 Manual Code number.		
3 (ADV Group)		Identical to the H100 Manual Code number.		
4 (CON Group)		Identical to the H100 Manual Code number.		
5 (IN Group)		Identical to the H100 Manual Code number.		
6 (OUT Group)		Identical to the H100 Manual Code number.		
7 (COM Group)		Identical to the H100 Manual Code number.		
8 (PID Group)		Identical to the H100 Manual Code number.		
9 (EPID Group)		Identical to the H100 Manual Code number.		
10 (AP1 Group)		Identical to the H100 Manual Code number.		
11 (AP2 Group)		Identical to the H100 Manual Code number.		
12 (AP3 Group)		Identical to the H100 Manual Code number.		
13 (PRT Group)		Identical to the H100 Manual Code number.		
14 (M2 Group)		Identical to the H100 Manual Code number.		

Service

Service Code	Definition	Support for Class	Support for Instance
0x0E	Get Attribute Single	No	Yes
0x10	Set Attribute Single	No	Yes

11.4 Modbus TCP

11.4.1 Modbus/TCP frame structure

MBAP Header(7 bytes)	PDU (5 bytes -)
-----------------------	-----------------

In general, Ethernet communication uses the EtherNet II frames.

MODBUS Application Protocol Header (MBAP Header)

The following table explains the components of a MBAP header.

Section	Length	Description
Transaction Identifier	2 Bytes	Unique transmission number, which increases by 1 each time the client sends data frame to the server
Protocol Identifier	2 Bytes	Fixed at 0.
Length	2 Bytes	Data frame length of the Modbus communication, which represents the length (in byte) from the MBAP header to the unit identifier
Unit Identifier	1 byte	When communications using Modbus TCP and Modbus RTU are connected via a gateway, the unit identifier indicates the slave number. The address is fixed to 0xFF when Modbus TCP communication is used alone.

Protocol Data Unit (PDU)

PDU is the actual data in the Modbus TCP communication, which is composed of a function code and data.

Refer to “11. 4. 2 Function Code” below for detailed information.

11.4.2 Function codes

The Modbus TCP communication involves clients and a server. During communication, clients send commands to the server, and the server responds to the commands. In general, devices, such as a PLC, HMI, and PC, are used as the client, and the inverter works as a server.

① Read Holding Registers

Read Holding registers are functions used to read the server (inverter) data.

The following table explains the components of a request data frame from a client to a server.

Request frame	Length	Value
Function Code	1 Byte	0x03
Comm. address	2 Bytes	0x0000 - 0xFFFF
Number of data requests	2 Bytes	1–16 (LS ELECTRIC inverters)

The following table explains the components of a response data frame from a server to a master.

Response frame	Length	Value
Function Code	1 Byte	0x03
Comm. address	1 Byte	2 x the number of data requests
Number of data requests	Number of data requests x 2 bytes	Data value of the given number from the comm. address

② Read Input Registers

Read Holding registers are functions used to read the server (inverter) data.

The following table explains the components of a request data frame from a client to a server.

Request frame	Length	Value
Function Code	1 Byte	0x04
Comm. address	2 Bytes	0x0000 - 0xFFFF
Number of data requests	2 Bytes	1–16 (LS ELECTRIC inverters)

The following table explains the components of a response data frame from a server to a master.

Response frame	Length	Value
Function Code	1 Byte	0x04
Comm. address	1 Byte	2 x the number of data requests
Number of data requests	Number of data requests x 2 bytes	Data value of the given number from the comm. address

③ Write Single Register

Write Single registers are functions used to write one server (inverter) data.

The following table explains the components of a request data frame from a client to a server.

Request frame	Length	Value
Function Code	1 Byte	0x06
Comm. address	2 Bytes	0x0000 - 0xFFFF
Data value	2 Bytes	0x0000 - 0xFFFF

The following table explains the components of a response data frame from a server to a master.

Response frame	Length	Value
Function Code	1 Byte	0x06
Comm. address	2 Bytes	0x0000 - 0xFFFF
Data value	2 Bytes	0x0000 - 0xFFFF

④ Write Multiple Register

Write Multiple registers are functions used to write 1 to 16 consecutive data on the server (inverter).

The following table explains the components of a request data frame from a client to a server.

Request frame	Length	Value
Function Code	1byte	0x10
Comm. address	2bytes	0x0000 - 0xFFFF
Number of data to write	2bytes	1–16 (LS ELECTRIC inverters)

Request frame	Length	Value
Byte Count	1 byte	2 x the number of data
Data value to write	Number of data x 2 bytes	Data to write

The following table explains the components of a response data frame from a server to a master.

Response frame	Length	Value
Function Code	1 Byte	0x10
Comm. address	2 Bytes	0x0000 - 0xFFFF
Number of data to write	2 Bytes	1–16 (LS ELECTRIC inverters)

⑤ Read Device Identification

The Read Device Identification is a function used to read the ID and additional information related to the functional description of remote devices from the server (inverter). This function is used to identify the information about the built-in Ethernet communication module.

Object ID	Object Name	Description	Category
0x00	Manufacturer Name	Manufacturer	Basic
0x01	Modbus Map Identifier	Modbus map ID of the product	
0x02	Modbus Map Version	Modbus map version	
0x03	Product URL	URL for the product origin	Regular
0x04	Product Name	Product name	
0x05	Model Name	Model type	
0x06	User-defined Device Name	-	
0x80	Serial Number	Serial number of the communication module	Extended
0x81	Product Number	Product number of the communication module	
0x82	Hardware Version	H/W number of the communication module	
0x83	Software Version	S/W number of the communication module	
0x84	Model Description	Description about the communication module	

Address and type of the requested object are decided depending on the Read Device

ID code.

0x01: Used to request an object in the Basic category as a stream.

0x02: Used to request an object in the Regular category as a stream.

0x03: Used to request an object in the Extended category as a stream.

0x04: Used to request a single, specific object.

The following table explains the components of a request data frame from a client to a server.

Request frame	Length	Value
Function Code	1 byte	0x2B
MEI Type	1 byte	0x0E
Read Device ID code	1byte	01 / 02 / 03 / 04
Object Id	1byte	0x00 - 0x06, 0x80 - 0x84; Start Object ID to request

The following table explains the components of a response data frame from a server to a master.

Response frame	Length	Value
Function Code	1 Byte	0x2B
MEI Type	1 Byte	0x0E
Read Device ID code	1 Byte	01 / 02 / 03 / 04
Conformity level	1 Byte	0x83
More Follows	1 Byte	0x00, no more Object are available
Next Object Id	1 Byte	0x00
Number of objects	1 Byte	Number of requested objects
List Of_ Object ID	1 Byte	Object ID of the requested object
List Of_ Object length	1 Byte	Object ID data length
List Of_ Object Value	(Object length) Bytes	Object ID data (Depending on the object ID)
...

11.4.3 Exception frame

An exception frame is a response frame from a server when an error occurs while responding to the client.

Exception frame structure

Error frame	Length	Value
Error code	1 byte	0x80 + Function Code requested by the client
Exception Code	1 byte	0x0000 - 0xFFFF

Exception code types

Type	Code	Description
ILLEGAL FUNCTION	0x01	Unsupported function has been requested
ILLEGAL DATA ADDRESS	0x02	An unused address has been requested or modification has been requested for the data at an unused address.
ILLEGAL DATA VALUE	0x03	A data modification request has been made out of the range of the available value.
SLAVE DEVICE FAILURE	0x04	Server error occurred (CAN communication error with the inverter, communication module initialization error, or data communication error with the inverter)
SLAVE DEVICE BUSY	0x06	Server is unable to respond because it is executing another process (When an initialization of the inverter or the communication module is in progress, etc.)
WRITE PERMISSION ERROR	0x14	Unique code for LS ELECTRIC inverters. An attempt was made to change a write-protected parameter

11.5 LED Indications and troubleshooting

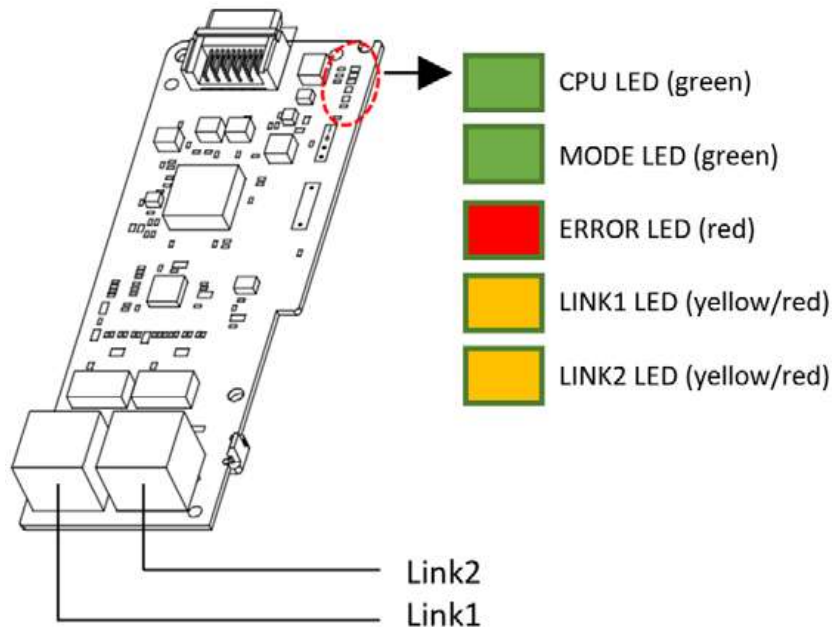

LED indicator	Color	Description	Operation	Status
LINK1	Red	Network normal	ON	Network connection at LINK 1 is operating normal
		LINK 1 Not connected	OFF	Trying Ethernet communication or the network cable not connected to LINK 1
	Yellow	Switch speed *1	ON	100 Mbps
			OFF	10 Mbps
LINK2	Red	Network normal	ON	Network connection at LINK 2 is operating normal.
		LINK 2 Not connected	OFF	Trying Ethernet communication or the network cable not connected to LINK 2
	Yellow	Switch speed *1	ON	100 Mbps
			OFF	10 Mbps

*1: Check the second bits set at COM-11 to view the Ethernet speed settings.

LED indicator	Color	Description	Operation	Status
CPU	Green	Normal	Blinking	The communication module has

LED indicator	Color	Description	Operation	Status
		operation	0.5s on/ 0.5 off	been properly installed on the inverter.
			OFF	Standing by for communication module operation
			ON	Communication module is booting up.
			Single Flash	-
MODE *2	Green	Normal operation	Always ON	BACNet/IP is in operation
			Blinking 0.5s ON /0.5s OFF	Ethernet/IP is in operation
			Blinking 0.2s ON /0.8s OFF	Modbus TCP is in operation
ERROR	Red	Normal operation	OFF	Operating properly
		ESC communication fault	Blinking 0.5s ON / 0.5 OFF	Communication module error
			Blinking 0.1s ON /0.1s OFF	IP address collision occurred. * The LED disappears only when IP address is set and rebooted.
			Single Flash 0.2s ON /1s OFF	EEPROM error
			Double Flash 0.2s ON /0.2s OFF /0.2s ON /1s OFF	LOST COMMAND
			ON	Fault occurred

*2 The MODE indicator will be lit when the setting at COM-21 (Opt parameter-12) is applied to the communication module after COM-94 (Comm Update) has been set to "1: yes."

12 Web server

12.1 Overview

Because the H100 Ethernet communication module has built-in web server functionalities, you can monitor the H100 inverter and check parameter settings, network status, and trip fault history on a web browser without installing additional programs. As long as a web browser (Chrome) is available, you can connect to the H100 Ethernet communication module in any environment.

12.2 Logging in

Chrome web browser fully supports access to the H100 Ethernet communication module’s web server. However, compatibility with other web browsers cannot be guaranteed. Also, the network environment must be configured without duplications and all wiring connections must be properly made. Run Chrome and enter the target IP address.



(The default IP is “192.168.1.10” without additional user settings.)

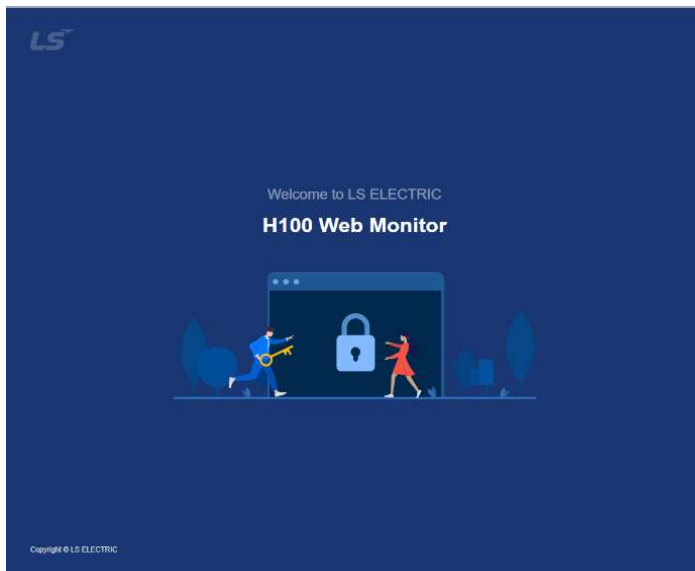

Log in to access your account

Admin

Password

There are two accounts available: Admin and User Each account has differentiated permission levels. The following table lists the permissions allowed for each account.

Account	Permission	Description
Admin	Accessing Dashboard, Monitoring,	The password is set with

Account	Permission	Description
	Drive Parameter, Setting, and Alarm menus is allowed and parameter changes are allowed within the Setting menu.	the BAC password parameter within the H100 inverter.
User	Accessing Dashboard, Monitoring, Drive Parameter, and Alarm menus are allowed.	Password is not required.

When you log in to the web server, a notification message is provided in a pop-up window. You can proceed with the login process after agreeing to the notification message.

12.3 Basic layout

When you log in to the web server for the first time, the Dashboard page will be displayed on the screen. The following table explains the basic layout of the H100 web server.

Menu	Item	Description	Description
Dashboard	Overall status of the H100 inverter	Main page of the web server. Provides the overall status at a glance.	
Monitoring	Drive	A page that allows you to monitor the inverter's operation status.	
	DI/DO	A page that allows you to monitor the inverter's I/O terminal status.	
	Chart	A page that allows you to select and monitor a specific item.	1Item; (10datas/Sec)
	Communication Module	A page that allows you to view the operation status of the Ethernet communication module.	
Drive Parameter	DRV,BAS ... M2	A page that allows you to view the parameter settings within the inverter.	
Setting	Communication Module	A page that allows you to view operation status of the Ethernet communication module and configure network settings.	Cannot be accessed with the user account
	Maintenance	A page that allows you to enter	Cannot be

Menu	Item	Description	Description
		information related to the inverter maintenance information, etc.	accessed with the user account
Alarm	Alarm List	A page that allows you to view the trip and warning history.	

The web server menus do not provide features to operate the inverter. Also, only data related to remote protocols, the network, etc. can be written on the web server.

12.3.1 Dashboard

A main page of the web server, which provides key information at a glance.

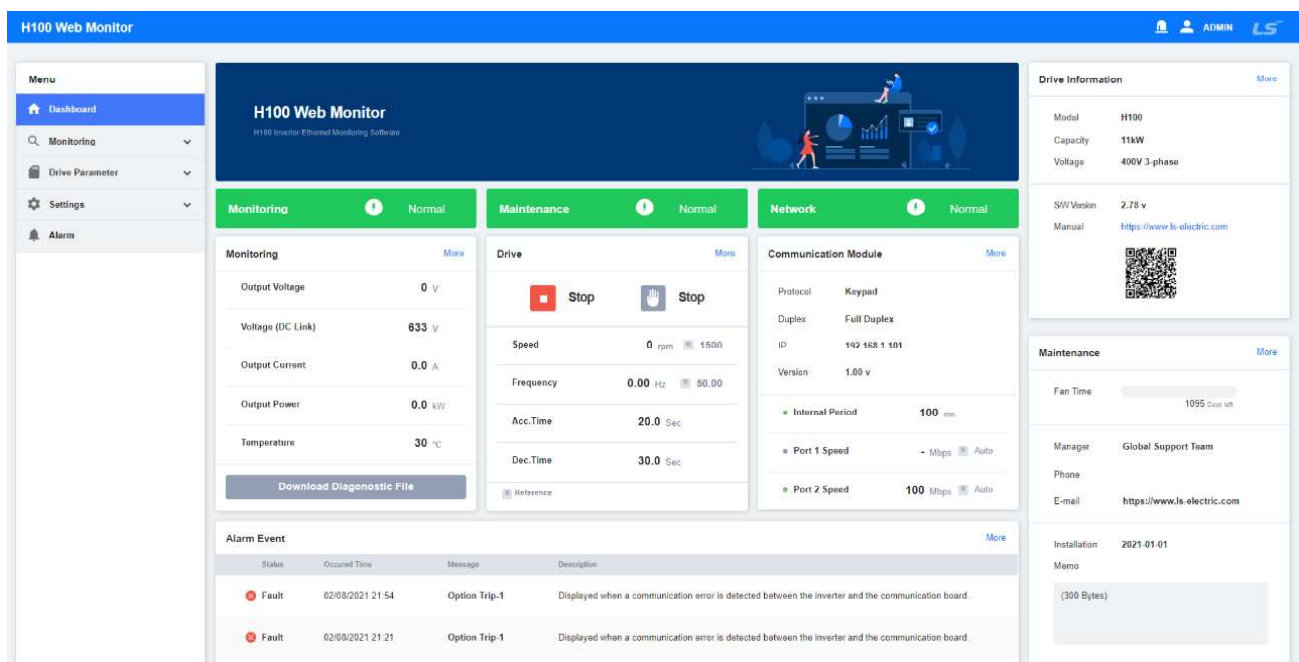

The status bars beneath the main banner indicate the event status for the given keywords. You can click the status bar to access the relevant information page.

Status Bar	Normal	Warning	Fault
Monitoring	Inverter is normal	Warning according to the inverter setting	Trip according to the inverter

Status Bar	Normal	Warning	Fault
			specification/setting
Maintenance	Fan condition is OK for the period	Warning about the period and fan status	Fatal failure of the built-in fan.
Network	Communication module network status is OK	-	Background CAN communication error between the inverter and the communication module

The Monitoring and Drive windows provide the current operation status of the inverter. You can click “More” to access the Drive page under the Monitoring menu.

The Drive Information window provides the model type, capacity, voltage, and software version of the currently installed inverter. You can click “More” to access the Drive page under the Drive Parameter menu.

The Maintenance window shows the notes written by the administrator and the fan status. You can click “More” to access the Maintenance page under the Setting menu.

The Alarm Event window provides the list of events that occurred since the installation of the communication module to the inverter and the first power on, while the Dashboard window shows only the two most recent events. You can click “More” to access the Alarm page.

12.3.2 Monitoring

A menu item that includes the monitoring area of the inverter and the communication module. All monitored items except for Chart are refreshed once every three seconds. On all subordinate pages under the Monitoring menu, you can download the diagnostics files.

12.3.2.1 Monitoring > Drive

A page that allows you to view the current operation status of the inverter. **R** (reference) stands for the target value of the current operation.

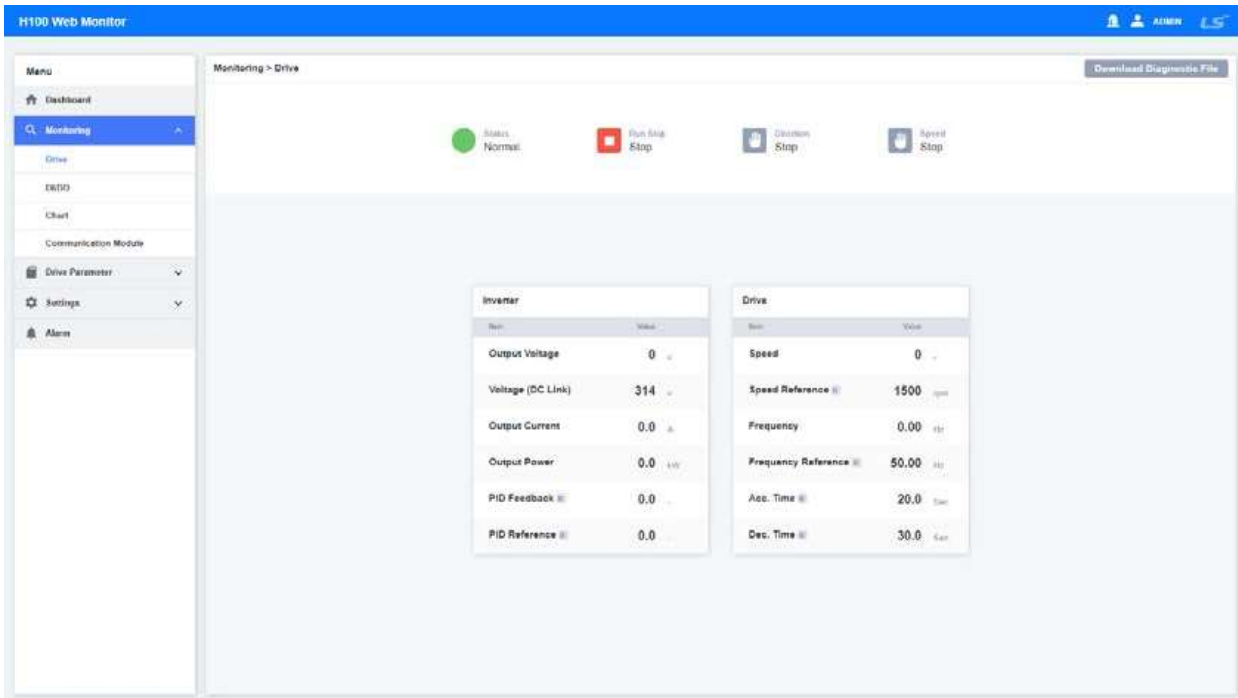

12.3.2.2 Monitoring > DI/DO

A page that allows you to view the current I/O terminal status of the inverter.

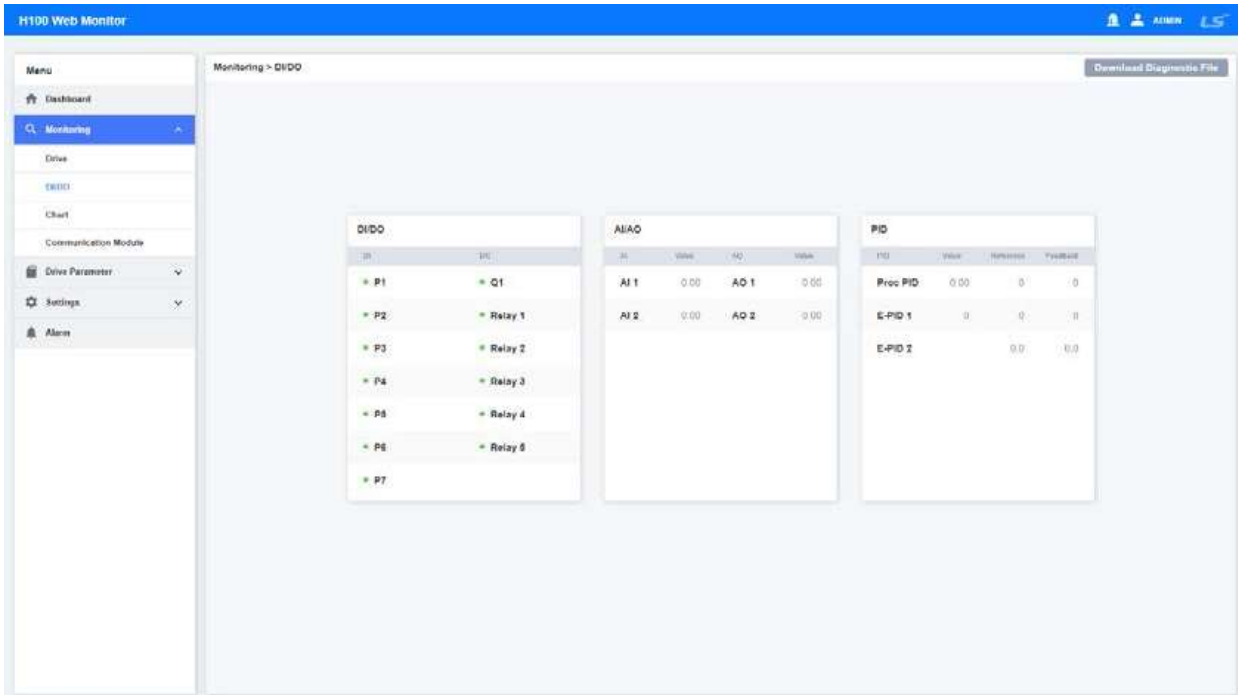

Green: Close

Grey: Open

12.3.2.3 Monitoring > Chart

A page that allows you to view the real-time operating values of the inverter. You can select up to eight items for real-time monitoring.

The screenshot shows the H100 Web Monitor interface. The top header is blue and contains the text 'H100 Web Monitor' on the left and user information 'ADMIN' on the right. A left-hand menu is visible, with 'Monitoring' selected. The main content area is titled 'Monitoring > Chart' and features a 'Download Diagnostic File' button in the top right. Below the title, there is a prompt 'Select 0 or fewer objects to monitor' and three dropdown menus for 'General', 'Analog', and 'Binary', each currently showing 'Selected (0)'. A green 'Start' button is positioned to the right of these dropdowns. The central part of the page is a large empty grid for a chart, with a y-axis ranging from 0 to 1.0 and an x-axis from 0 to 100. A 'Download' button is located at the bottom center of the chart area. To the right of the chart is a 'Real-time Legend' section.

Click “Start” to start monitoring. Click “Stop” to stop monitoring.

To view the detailed information about a trend, you can zoom in a part of the trend by dragging the mouse cursor over it while the monitoring feature is stopped. To return to the previous view (zoom out), click “Reset.”

The Real-time Legend shows the most recent values in real time.

Click “Download” to download the data up to the point that was last monitored. The data can be downloaded only for up to 10 minutes.

12.3.2.4 Monitoring > Communication Module

A page that allows you to view the current operation status of the communication module. **R** (reference) stands for the target value of the current operation.

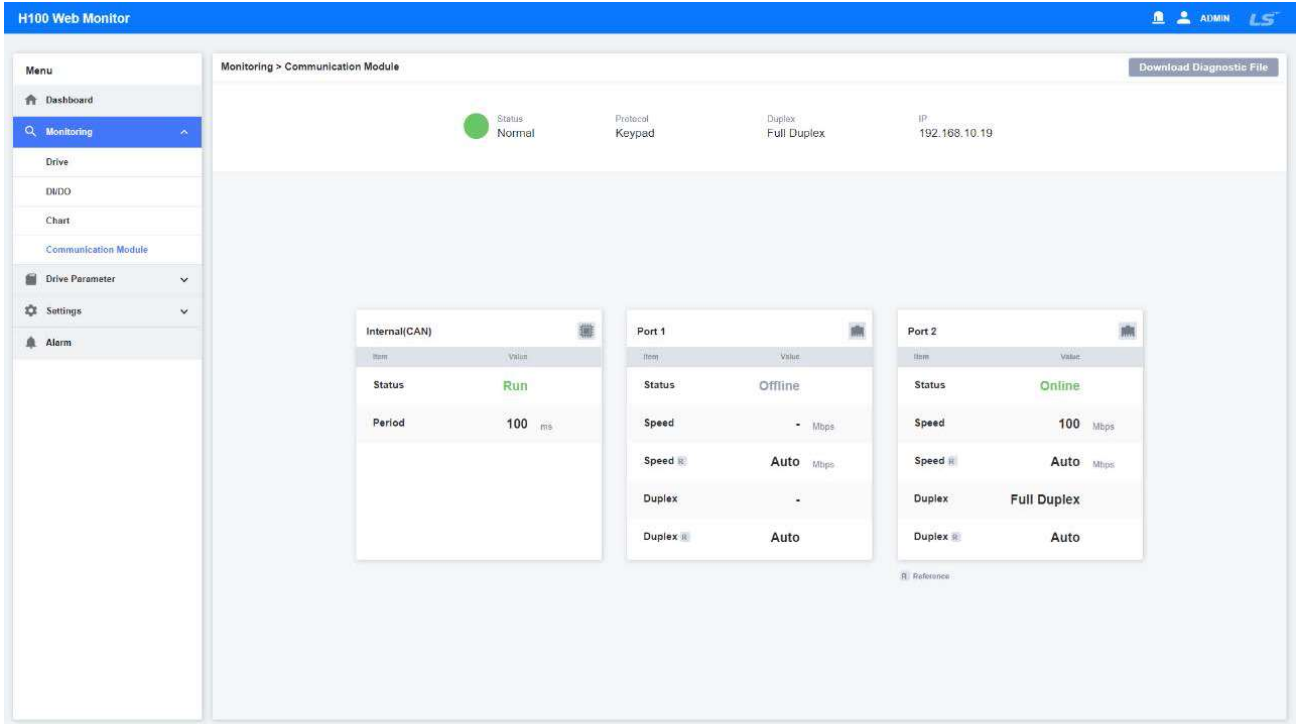

Interface (CAN): Refers to the communication status between the inverter and the Ethernet communication module. Period stands for the background communication interval between the devices.

Port 1 and 2: Refer to the actual link statuses of the Ethernet port and the switch operation speed/mode. Configure COM-11 (Opt Parameter2) to change the settings.

Note) The web server may become unstable when the speed is set as “10 Mbps.”

12.3.3 Drive Parameter

Loads the parameter values set within the inverter. All parameter values are based on the information included in H100 User Manual. Refer to H100 User Manual for detailed information.

The parameter values at the time when the communication module was first installed to the inverter will be displayed here. To identify the parameter value changes after the communication module was operated, click “Refresh” on each parameter group page to reload the changed values. When the values are refreshed, not all values of all parameter groups will be newly loaded; only the parameter values provided on

each page will be separately loaded.

The screenshot shows the 'H100 Web Monitor' interface. The main content area is titled 'Drive Parameter > Drive' and contains a table with the following data:

Item	Value	Unit	Default	Range	Writable
Command Frequency	0.00	Hz	0.00	0.00: Low Freq - High Freq	○
Keypad Run Dir	1		1	0: Reverse 1: Forward	○
Acceleration Time	20.0	sec	20.0	0.0 - 600.0 (sec)	○
Deceleration Time	30.0	sec	30.0	0.0 - 600.0 (sec)	○
Keypad H.O.A Lock	1		1	0: Locked 1: Diarming Run 2: Unlocked	△
Command Source	1		1	0: Keypad 1: Fx/Rx-1 2: Fx/Rx-2 3: Int 485 4: Field Bus 5: Time Event	△
Frequency Reference Source	0		0	0: Keypad-1 1: Keypad-2 2: V1 3: V2 4: I2 5: Int 485 7: FieldBus 8: Pulse 10: V3 11: I3	△
Control Mode	0		0	0: V/F 1: Slip Compens	△
Jog Frequency	10.00	Hz	10.00	0.00: Low Freq - High Freq	○
Jog Acc Time	20.0	sec	20.0	0.0 - 600.0 (sec)	○

The 'Drive Information' panel on the right shows the following details:

- Model: H100
- Capacity: 5.5KW
- Voltage: 200V 3-phase
- SW Version: 2.76 v
- Manual: <https://lselectric.co.kr>

As shown in the figure above, green dots are displayed for the items with changed values that do not match the initial values. Besides this, parameter values that were changed or unspecified by third party devices will also be indicated with green dots. However, these indications will not be provided for external parameter groups.

(Example: “-”, “Motor setting”)

12.3.4 Setting

This menu allows you to view other information related to the H100 Ethernet communication module and the inverter. This menu can only be accessed with the Admin account.

12.3.4.1 Setting > Communication Module

This menu allows you to configure the protocol and TCP/IP settings for the H100 Ethernet communication module and update the firmware.

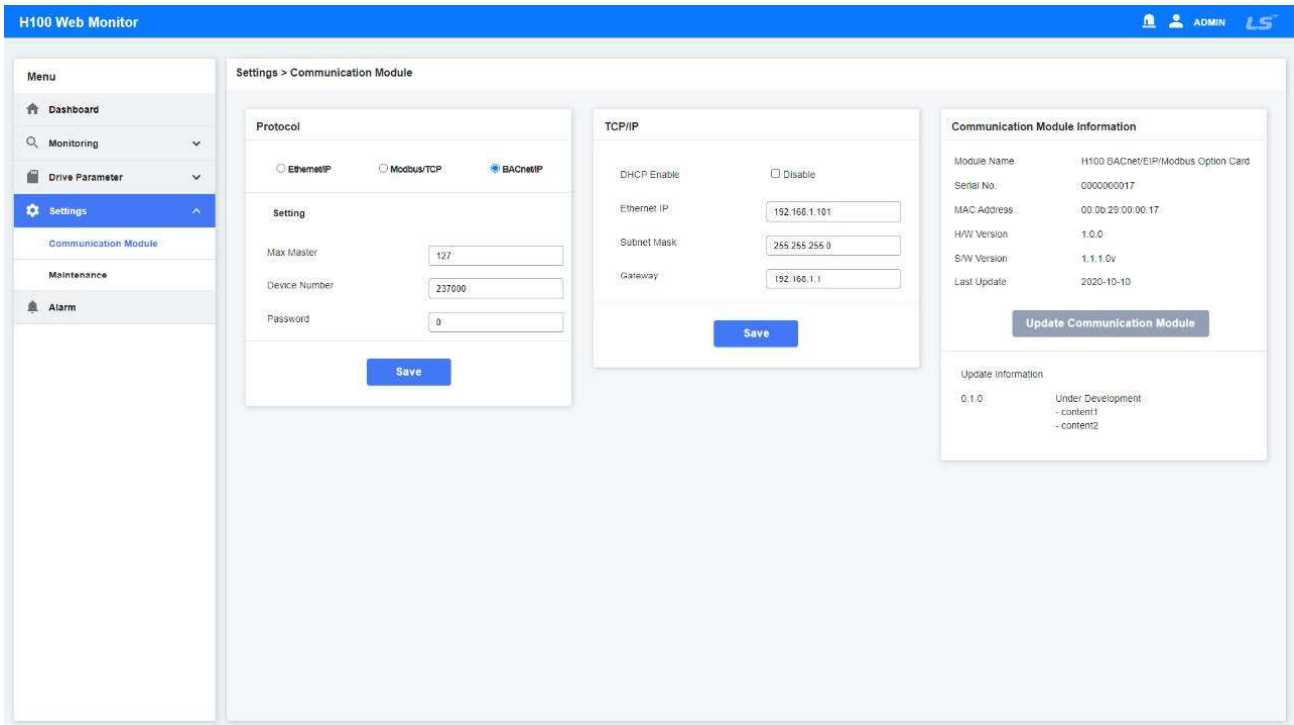

Protocol: Set the options for the currently selected protocol. After selecting the check box and saving the protocol, the changes will take effect from the next booting of the device.

Related parameters - COM-21, COM-22, COM-23, COM-83,
COM-84, COM-85, and COM-86

TCP/IP: Configure the network settings. These settings provides the same functions as parameters from COM-12 to COM-20.

Communication Module Information: This window provides detailed information about the currently installed Ethernet communication module. You can click “Update Communication Module” to update the firmware for the Ethernet communication module only.

12.3.4.2 Setting > Maintenance

This page allows you to enter other information related to the inverter.

Installation: This window allows you to record brief information about the inverter and the communication module, or write memos.

Asset Management: Indicates the effective lifespan of the cooling fan and the operation period of the inverter.

12.3.5 Alarm

This page allows you to view event history of the inverter. By default, the most recent fault trip event history (for up to five items) is displayed here. In addition to this, the most recent warning event history (up to five items) is stored on the communication module while it is powered on. The warning event history will be erased when the power to the communication module is turned off.

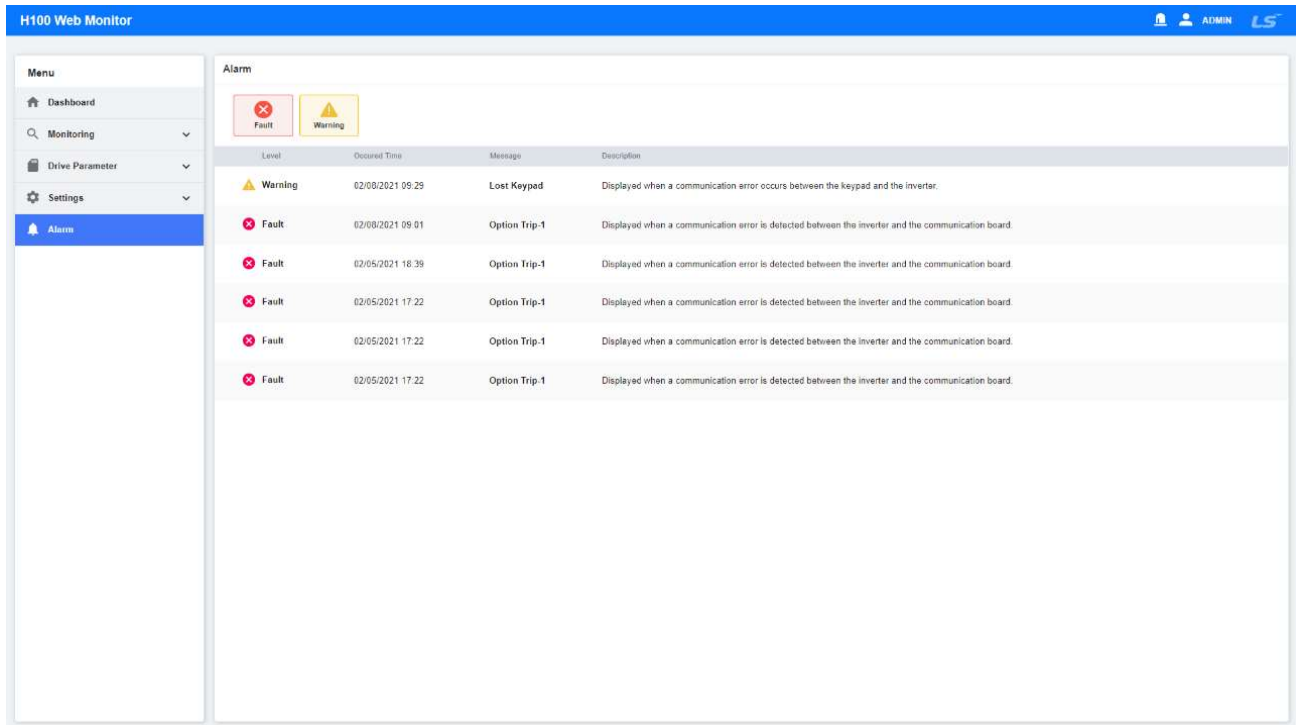

The Occurred Time on the alarm list is decided according to the Application 3 Now Date (AP3-01), Now Time (AP3-02), and Date Format (AP3-06) settings in the Drive Parameter menu.

Click the relevant list to view detailed information about the fault trip history. Identify the detailed history at the time of any event. However, the detailed event history of a warning cannot be identified.

12.3.6 Notes

Note the following information related to the Chrome browser.

- a. The downloading of files (diagnostics and chart files) is available in Safari (on devices running iOS). However, the download feature is not supported in Chrome due to the browser's internal problems.
- b. During the next booting process, the protocol selections (checked protocols) in the Setting > Protocol menu will be applied.

- c. When you reboot the inverter on the web server or via the keypad, all currently established web connections will be forcibly terminated.
- d. Excessive remote/web requests (by each protocol) will result in a heavy system load for internal processing, deteriorating the performance of the chart feature (Monitoring > Charts).
- e. Please proceed with the update when the Drive isn't working.
- f. If the Diagnostic File contains any unintended content, please remove the cache in the browser and reconnect to proceed with the download.