

MEsoftstart – industry-hardened low-voltage soft starter

USERS INSTALLATION & INSTRUCTION MANUAL

Applies to models:

- MEsoftstart/I00 (100A soft starter)
- MEsoftstart/I01 (200A soft starter)
- MEsoftstart/I02 (390A soft starter)
- MEsoftstart/I03 (600A soft starter)
- MEsoftstart/I04 (900A soft starter)

Thank you for choosing this Mitsubishi Electric Europe B.V. soft starter. This Instruction Manual provides installation instructions and guidelines for advanced use of the MEsoftstart series soft starters. Before using the soft starter carefully read this Manual and ensure to follow all Safety Instructions.



1. INTRODUCTION	7
2. INSTALLATION INSTRUCTIONS	17
3. WIRING	32
4. PRECAUTIONS FOR USE OF THE SOFT STARTER	45
5. BASIC OPERATION – CORE MODELS	49
6. BASIC OPERATION – PRO MODELS	62
7. MESOFTSTART COMMUNICATION INTERFACE	82
8. PROTECTIVE FUNCTIONS & TROUBLESHOOTING (PRO)	100
9. MAINTENANCE AND INSPECTION	106
10. SPECIFICATIONS	110
APPENDICES	117

This document is a DRAFT. Please ensure to get the latest release from your distributor

Revision History

Date	Document Number and Revision	Change log
February 2018	A018_070_INT_EN_001	Release edition for training
August 2018	A018_070_INT_EN_002 – Draft A	First update
September 2018	A018_070_INT_EN_002	Updated for upgraded build of MEssoftstart
November 2018	A018_070_INT_EN_003	Name update (MEsoftstart)
December 2018	A018_070_INT_EN_003B	Updated wiring diagrams, Auto/Maintenance feature, Bypass contactor specs updated
February 2019	A018_070_INT_EN_003D	Updates for Core error pattern

For Maximum Safety

- Mitsubishi Electric Europe B.V. Soft starters are not designed or manufactured to be used in equipment or systems in situations that can affect or endanger human life
- When considering this product for operation in special applications such as machinery or systems in passenger transportation, medical, aerospace, atomic power or submarine applications, please contact your nearest Mitsubishi Electric sales representative
- Although this product was manufactured under conditions of strict control, you are strongly advised to install safety devices to prevent serious accidents when it is used in facilities where breakdowns of the product are likely to cause serious accident.
- Please check upon receiving your soft starter whether this instruction manual corresponds to the delivered Soft starter. Compare the specifications on the label with the specifications given in this manual

TABLE OF CONTENTS

1. INTRODUCTION	7
1.1 SOFT STARTER SELECTION	8
1.2 CHECKING THE PRODUCT WHEN UNPACKING	13
1.3 COMPONENT AND TERMINAL IDENTIFICATION	14
2. INSTALLATION INSTRUCTIONS	17
2.1 PREPARING FOR SOFT STARTER INSTALLATION	18
2.2 MOTOR CONTROL CENTRE CABINET DESIGN	23
2.3 SOFT STARTER INSTALLATION	27
3. WIRING	32
3.1 TERMINAL IDENTIFICATION	33
3.2 WIRING INSTRUCTIONS	35
4. PRECAUTIONS FOR USE OF THE SOFT STARTER	45
4.1 CHECKLIST BEFORE APPLYING POWER	46
5. BASIC OPERATION – CORE MODELS	49
5.1 POWER-UP THE SOFT STARTER	50
5.2 CONFIGURE THE SOFT STARTER FOR THE APPLICATION	51
5.3 CONTROLLING THE SOFT STARTER	53
5.4 TROUBLESHOOTING THE MESOFTSTART/I CORE VARIANT	56
6. BASIC OPERATION – PRO MODELS	62
6.1 OPERATIONAL MODES OF THE SOFT STARTER	63
6.2 POWER-UP THE SOFT STARTER	64
6.3 METHOD OF VIEWING AND CHANGING CONFIGURATION PARAMETERS	64
6.4 PARAMETERS	65
6.5 PARAMETER INTER-DEPENDENCIES	75
6.6 BASIC OPERATION PROCEDURE - OPERATION FROM TFT DISPLAY PANEL	76
6.7 BASIC OPERATION PROCEDURE – OPERATION FROM A REMOTE CONTROLLER	79
6.8 USING THE AUTO/MAINTENANCE-FEATURE	81
7. MESOFTSTART COMMUNICATION INTERFACE	82
7.1 MESOFTSTART PC APP	83
7.2 MESOFTSTART MODBUS INTERFACES	98
8. PROTECTIVE FUNCTIONS & TROUBLESHOOTING (PRO)	100
8.1 SOFT STARTER FAULT AND ALARM INDICATIONS	101
8.2 HOW TO RESET THE SOFT STARTER AFTER A FAULT HAS OCCURRED	101
8.3 TROUBLESHOOTING USING THE FAULT DISPLAY ON THE SOFT STARTER	102
8.4 GENERAL TROUBLESHOOTING	105
9. MAINTENANCE AND INSPECTION	106
9.1 INSPECTION ITEM	107
10. SPECIFICATIONS	110
10.1 SOFT STARTER SPECIFICATION	111
10.2 OUTLINE DIMENSION DRAWINGS	112
APPENDICES	117
ADVANCED MAINTENANCE: REPLACEMENT OF THE FAN	118

Safety Instructions

Do not attempt to install, operate, maintain or inspect the product until you have read through this Instruction Manual and can use the equipment correctly. Do not use this product unless you have a full knowledge of the equipment, safety information and instructions and are qualified to do installations of this nature.

Installation, operation, maintenance and inspection must be performed by qualified personnel. Here, an expert means a person who meets all the conditions below:

- A person who has proper engineering training. Such training may be available at your local Mitsubishi Electric office. Contact your local sales office for schedules and locations.
- A person who can access the operating manuals.
- A person who has read and familiarized themselves with the manuals.

In this Instruction Manual, the safety instruction levels are classified into "Warning" and "Caution":

WARNING

Incorrect handling may cause hazardous conditions, resulting in death or severe injury.

CAUTION

Incorrect handling may cause hazardous conditions, resulting in medium or slight injury, or may cause only material damage.

Note that even the CAUTION level may lead to serious consequences under certain conditions. Please follow the instructions of both levels. They are important for personnel safety.

Electric Shock Prevention

WARNING

- Do not open the soft starter enclosure while there is power on the soft starter power terminals.
- Ensure that the power is OFF (MCCB open) before working on the motor or any load connected to the motor. Do not assume that the power at the motor is OFF while the power to the soft starter is still ON.
NOTE: When wired for inside-delta connection, the six motor terminals remain live even when the motor is off.
- Do not run the soft starter with the cover removed - this increases the risk of access to the exposed terminals and electric shock.
- Even if power is OFF, do not open the soft starter enclosure.
- Before wiring or inspection, the power must be switched OFF.
- This soft starter must be earthed (grounded). Earthing (grounding) must conform to the requirements of national and local safety regulations and electrical code (NEC section 250, IEC 536 class 1 and other applicable standards).
- Any person who is involved in wiring or inspection of this equipment shall be fully competent to do the work.
- The soft starter must be installed before wiring otherwise there is a risk of electric shock or injury.
- Ensure that cables are not damaged, under excessive stress or pinched anywhere otherwise there is a risk of causing a short circuit or even electric shock.
- Do not change the cooling fan while power is ON - this is dangerous.
- Do not touch any part of the soft starter or handle the cables with wet hands- this increases the risk of electric shock.

Fire Prevention

CAUTION

- The soft starter must be installed against a non-flammable surface - mounting it in proximity of flammable material may result in a fire.
- If the soft starter has become faulty, the soft starter power must be switched OFF. A continuous flow of large current may cause a fire.
- Be sure to perform daily and periodic inspections as specified in the Instruction Manual. If a product is used without regular inspection, damage or even a fire may occur.

Injury Prevention

CAUTION

- The voltage applied to each terminal must be as specified in the Instruction Manual - otherwise damage will occur.
- The cables must be connected to the correct terminals - otherwise damage may occur.
- The connection order of the phases must be correct.
- While power is ON or for some time after it was ON, do not touch the soft starter as it may be extremely hot and could inflict a burn injury.

Usage

CAUTION

- The soft starter's built-in temperature trip functions can only protect the motor from overheating if the motor temperature sensor is wired in and connected to the motor at an appropriate temperature sensing location.
- The effect of electromagnetic interference must be reduced by using a noise filter or by other means. Otherwise nearby electronic equipment may be affected.
- Before running a soft starter, which had been stored for a long period, inspection and test operation must be performed.
- Static electricity in your body must be discharged before you touch the product.
- Some of the diagrams, drawings and photographs in the Instruction Manual shows the product without a cover or partially open for explanation. Never operate the product in this manner. The cover(s) must be always re-installed before operating the soft starter.
- Earthing Leakage detection is not active when Inside Delta motor wiring configuration is used.

Transportation and Installation

CAUTION

- Any person who is opening a package using a sharp object, such as a knife and cutter, must wear gloves to prevent injuries caused by the edge of the sharp object.
- The product must be transported in an appropriate method for the weight of the package. Failure to do so may lead to injuries.
- Do not stand or rest heavy objects on the product.
- Do not stack the boxes containing soft starters higher than the number recommended.
- During installation, caution must be taken not to drop the soft starter as doing so may cause injuries and damage to the product.
- The product must be installed against a surface that withstands the weight of the soft starter.
- Do not install the product on a hot surface.
- The mounting orientation of the soft starter must be correct.
- The soft starter must be installed on a strong surface securely with screws so that it will not drop.
- Do not install or operate the soft starter if it is damaged or has parts missing.
- Foreign conductive objects must be prevented from entering the soft starter. That includes screws and metal fragments or flammable substance such as oil.
- As the soft starter is a precision instrument, do not drop or subject it to impact.
- For the all ranges of the soft starter, the surrounding air temperature must be 0 to +50°C - Otherwise the soft starter may be damaged.
- The ambient humidity specification must be adhered to. Otherwise the soft starter may be damaged. (Refer to par 2.2.2.2 for details.)
- The storage temperature (applicable for a short time, e.g. during transit) specification must be adhered to. Otherwise the soft starter may be damaged.
- The soft starter must be used indoors (without corrosive gas, flammable gas, oil mist, dust and dirt etc.) Otherwise the soft starter may be damaged.
- The soft starter can be used as rated, at an altitude of 1400 m or less above sea level. Higher altitudes require de-rating.
- The soft starter should not be subjected to operational vibration. The soft starter is designed for transportation vibration only. (Refer to paragraph 2.2.2.7 for details.)
- If halogen-based materials (fluorine, chlorine, bromine, iodine, etc.) infiltrate into a Mitsubishi Electric product, the product will be damaged. Halogen-based materials are often included in fumigant, which is used to sterilize or disinfest wooden packages. When packaging, prevent residual fumigant components from being infiltrated into Mitsubishi Electric products, or use an alternative sterilization or disinfection method (heat disinfection, etc.) for packaging. Sterilization or disinfection of wooden package should also be performed before packaging the product.

Wiring

CAUTION

- The motor side terminals (terminals T1, T2 and T3) must be connected correctly. The soft starter will protect against phase reversal if configured to do so. If the soft starter is configured to not check the phase rotation, the motor will rotate inversely – which may, or may not be a problem in the installation.
- Never connect the motor side terminals (terminals T1, T2 and T3) to the grid power supply. Applying the grid power supply to motor terminals (T1, T2, T3) will damage the soft starter. The induction motor may be connected to the grid power supply only via a bypass contactor that is under control of the soft starter.
- Return wires from an Inside Delta motor connection should be connected to the Supply lines on L1, L2, L3 (and NOT on the Bypass terminals BL1 BL2 BL3)

Commissioning

CAUTION

- Before starting operation, each configuration parameter must be adjusted for the installation and motor size. A failure to do so may cause unexpected behaviour or damage to the motor.

Emergency Stop

CAUTION

- An independent hardware Emergency Stop must be provided as a safety measure to prevent hazardous conditions to the machine and equipment in case of soft starter failure (refer paragraph 2.2.2.8).
- When the breaker on the soft starter input side trips, the wiring must be checked for fault (short circuit). The cause of the trip must be identified and removed before turning ON the power on the breaker.
- When a fuse on the soft starter input blows, the wiring and the soft starter needs to be checked for faults. The cause of the blown fuse must be identified and removed before replacing the fuse and turning on again.
- When a protective function activates, take appropriate corrective action, then reset the soft starter and resume the operation.

Maintenance, inspection and parts replacement

CAUTION

- Do not carry out a megger (insulation resistance) test on the soft starter when connected. It may cause damage.

Disposal

CAUTION

- When unserviceable, the soft starter should be treated as industrial waste.

List of Abbreviations

Abbreviation	Definition
AC	Alternating Current
AC3	Device category for squirrel cage motors
AM	Amplitude Modulation
BAUD	Bits per second (relating to the Modbus link)
CE	Conformité Européenne (for conformity with protection standards of the European Economic Area)
COM	Communication port on PCs
CT	Current Transformer
EMC	Electromagnetic Compatibility
EMI	Electromagnetic Interference
FC	Function Codes (Modbus)
GND	Ground / Earthing
GPRS	General Packet Radio Service
HMI	Human Machine Interface
I/O	Input / Output
IEC	International Electro-technical Commission
L1	Supply Line Phase 1
L2	Supply Line Phase 2
L3	Supply Line Phase 3
MCCB	Moulded Case Circuit Breaker
MFLC	Maximum Full Load Current
MFS	Motor Frame Size (in kW)
MODBUS	Communication Protocol originally published by Modicon (now Schneider Electric) in 1979
MOLC	Motor Overload Current
MSC	Maximum Starting Current
MULC	Motor Underload Current
OC	Open Circuit
PC	Personal Computer
PF	Power Factor
PLC	Programmable Logic Controller
PTC	Positive Temperature Coefficient thermistor
RJ45	Connector standard (used for Modbus RTU and TCP communications on MESoftstart)
RMS	Root Mean Square
RPM	Revolutions per Minute
RS485	Electrical standard for use in serial communications (used for Modbus in MESoftstart)
RTD	Resistance Temperature Detector (e.g. PTC)
RTU / TCP	Protocol variants for Modbus (RTU for RS485 serial and TCP for Ethernet communication)
SC	Short Circuit
SCADA	Supervisory Control and Data Acquisition
SCR	Silicon Controlled Rectifier
SICD	Software Interface Control Document
TFT	Thin Film Transistor (display)
USB	Universal Serial Bus
VL-L	Voltage Line to Line

1. INTRODUCTION

Mitsubishi Electric Europe’s **MEsoftstart** microprocessor-based advanced digital soft starter range features bypass control for internal or external bypass and full 3-phase control. It incorporates both enhanced soft-start and soft-stop characteristics providing the best solution for a wide range of applications. Its comprehensive motor protection package guarantees long term reliability while the external bypass connections ensure flexibility and excellent performance – all in a compact, versatile design.

Two MEsoftstart variants are available namely “Core” and “Pro”:

- **Core** – Low-cost, simple-to-configure models, using 6 potentiometers each for start and stop ramp definition and a few slider switches to fully configure the soft starter. Monitoring and control with PC Application on Modbus RTU.
- **Pro** – Used for complex applications where more advanced control options are required. Setting up, Monitoring and Control with full-function local colour touch TFT screen (as shown) and/or PC Application on Modbus RTU or TCP.

This manual contains the Installation and Operating instructions for the MEsoftstart/I00 and MEsoftstart/I01 Core variants and the MEsoftstart/I01, MEsoftstart/I02, MEsoftstart/I03 and MEsoftstart/I04 Pro variants of the MEsoftstart range of Industrial soft starters.



⚠ Always read the instructions before connecting and using the equipment.

1. INTRODUCTION	7
1.1 SOFT STARTER SELECTION.....	8
1.2 CHECKING THE PRODUCT WHEN UNPACKING.....	13
1.3 COMPONENT AND TERMINAL IDENTIFICATION.....	14

1.1 Soft starter selection

The correct soft starter model needs to be selected according to the user's intended application and installation environment. The selection of the soft starter model can also be driven by a cost compromise between an expensive motor control centre enclosure / cabinet / panel design / long cables, or a higher rated soft starter model.

The selection of the soft starter model is dependent on the following characteristics of the user's installation:

- 1) **Motor size and connection type** – in general the soft starter current must be greater or equal to the motor full load current.
- 2) **Typical operating temperature** – the soft starter is rated at a nominal operational temperature of 50°C but may be operated up to 60°C. Implement de-rating of the soft starter maximum current at temperatures above 50°C. The operating temperature is determined by the environmental factors as well as the soft starter workload.
- 3) **Soft starter workload** – The workload is defined in two categories: Normal duty and Heavy duty. This comprises the typical starting time, the typical number of starts per hour and the running time (if no Bypass Contactor is installed)
 - a. **Typical starting time** – the shorter the starting time, the lower the thermal loading on the soft starter. A starting time of less than 30 seconds is considered normal duty. 30 second-starts and longer, are considered heavy duty.
 - b. **Typical number of starts per hour** – frequent starting increases temperature of the heat sink in the soft starter. Number of starts less than 10 per hour (or 6 minutes or longer between starts) are deemed normal duty. 10 or more starts per hour (or less than 6 minutes between starts) are considered heavy duty.
 - c. **Bypass contactor installed** – if the soft starter is used with an internal or external bypass contactor, the 'on-time' of the soft starter is only during starting and stopping – this reduces thermal loading and a smaller soft starter model may be appropriate. A bypass contactor is recommended for applications where the motor is started and then runs for a long time before it is stopped. For applications where frequent start-stop cycles are required, a bypass contactor is not recommended.
- 4) **Altitude above sea-level** – the MEsoftstart range of soft starters are designed and tested for operation up to 1400m above sea level. De-rating of the soft starter maximum and operating currents is needed for operation at higher altitude.

Definition of motor duty applied to MEsoftstart soft starters:

1. **Normal duty** is defined as no more than 10 starts per hour (> 6 min between starts) and start ramp shorter than 30s.
2. **Heavy duty** is defined as more than 10 starts per hour (<6 min between starts) or start ramp longer than 30s.

1.1.1 Motor size

The tables below serve as a guideline for selecting the correct model soft starter for the application according to the motor starting current and type of application. The tables below show the allowable starting current for the listed motor sizes as a percentage of their maximum normal running current at power factor of 0.8.

A bypass contactor is recommended for applications where the motor runs for a long or continuous periods. A bypass contactor reduces the current through the soft starter switching elements and can allow the use of a smaller soft starter and increases the efficiency of the installation.

Applications with short, frequent start and stop ramps should not use a bypass contactor for mechanical life reasons of the contactor. However, the soft starter needs to be sized correctly to handle the switching current for such heavy duty use.

Model **MEsoftstart/I00** soft starter is rated at 100A continuous current and can be used at 240A starting current for normal duty and at 125A starting current for heavy duty applications and can be ordered with a built-in bypass contactor or can be installed with an external bypass contactor, or without a bypass contactor. MEsoftstart/I00 can be ordered for voltage ranges from 400Vac to 690Vac and can be ordered with a built-in bypass contactor or can be installed with an external bypass contactor, or without a bypass contactor.

Model: **MEsoftstart/I00**

Continuous rated current: 100A
 Max. starting current: 240A Normal duty
 Max starting current: 125A Heavy Duty

Table 1: MEsoftstart/I00 guideline for motor sizes¹

Motor Size [kW]	MEsoftstart/I00 Normal 3-wire circuit						MEsoftstart/I00 6-wire inside delta circuit					
	400Vac Supply Voltage		525Vac Supply Voltage		690Vac Supply Voltage		400Vac Supply Voltage		525Vac Supply Voltage		690Vac Supply Voltage	
	Normal Duty	Heavy	Normal Duty	Heavy	Normal Duty	Heavy	Normal Duty	Heavy	Normal Duty	Heavy	Normal Duty	Heavy
11		625%										
15		446%		595%								
18.5		368%		481%		625%		625%				
22	600%	313%		403%		521%		521%		694%		
30	436%	227%		298%		391%		391%		521%		658%
37	358%	187%		245%		321%		321%		417%		543%
45	293%	152%		202%		260%		260%		347%		446%
55	240%			164%		216%		216%	667%	284%		368%
75				164%		158%		158%	400%	208%	522%	272%
90				231%		253%		253%	333%	174%	436%	227%
110									273%		358%	187%
132											296%	154%
160											245%	
200												

Model **MEsoftstart/I01** is rated at 200A continuous current and can be used at 480A starting current for normal duty and at 250A starting current for heavy duty applications. MEsoftstart/I01 can be ordered for voltage ranges from 400Vac to 690Vac and can be ordered with a built-in bypass contactor or can be installed with an external bypass contactor, or without a bypass contactor.

Model: **MEsoftstart/I01**

Continuous rated current: 200A
 Max. starting current: 480A Normal duty
 Max starting current: 250A Heavy Duty

¹ The tables show the allowable starting current for the listed motor sizes as a percentage of their maximum normal running current at power factor of 0.8 – in the case of motors with heavy duty starting requirements, use only the values from columns marked “Heavy duty”.

Table 2: MEdsoftstart/I01 guideline for motor sizes¹

Motor Size [kW]	MEdsoftstart/I01 Normal 3-wire circuit						MEdsoftstart/I01 6-wire inside delta circuit					
	400Vac Supply Voltage		525Vac Supply Voltage		690Vac Supply Voltage		400Vac Supply Voltage		525Vac Supply Voltage		690Vac Supply Voltage	
	Normal Duty	Heavy	Normal Duty	Heavy	Normal Duty	Heavy	Normal Duty	Heavy	Normal Duty	Heavy	Normal Duty	Heavy
22		625%										
30		455%		595%								
37		373%		490%		641%		641%				
45	585%	305%		403%		521%		521%		694%		
55	480%	250%	632%	329%		431%		431%		568%		
75	353%	184%	462%	240%	608%	316%	608%	316%		417%		543%
90	294%	153%	387%	202%	505%	263%	505%	263%	667%	347%		455%
110	241%		316%	164%	414%	216%	414%	216%	545%	284%		373%
132			264%		345%	180%	345%	180%	453%	236%	593%	309%
160					286%	149%	286%	149%	375%	195%	490%	255%
200									300%	156%	393%	205%
250									240%		316%	164%
315											250%	
355												
400												

Model **MEdsoftstart/I02** is rated at 390A continuous current and can be used at 730A starting current for normal duty and at 390A starting current for heavy duty applications. MEdsoftstart/I02 can be ordered for voltage ranges from 400Vac to 690Vac and can be ordered with a built-in bypass contactor or can be used with an external bypass contactor, or without a bypass contactor.

Model: **MEdsoftstart/I02**

Continuous rated current: 390A

Max. starting current: 730A Normal duty

Max starting current: 390A Heavy Duty

Table 3: MEdsoftstart/I02 guideline for motor sizes¹

Motor Size [kW]	MEdsoftstart/I02 Normal 3-wire circuit						MEdsoftstart/I02 6-wire inside delta circuit					
	400Vac Supply Voltage		525Vac Supply Voltage		690Vac Supply Voltage		400Vac Supply Voltage		525Vac Supply Voltage		690Vac Supply Voltage	
	Normal Duty	Heavy	Normal Duty	Heavy	Normal Duty	Heavy	Normal Duty	Heavy	Normal Duty	Heavy	Normal Duty	Heavy
22												
30												
37		582%										
45		476%		629%								
55		390%		513%		672%		672%				
75	537%	287%		375%		494%		494%		650%		
90	448%	239%	589%	315%		411%		411%		542%		
110	367%	196%	480%	257%	629%	336%	629%	336%		443%		582%
132	305%	163%	401%	214%	525%	281%	525%	281%	689%	368%		481%
160	253%		332%	177%	435%	232%	435%	232%	570%	305%		398%
200	202%		265%		348%	186%	348%	186%	456%	244%	598%	320%
250			212%		279%	149%	279%	149%	365%	195%	480%	257%
315					221%		221%		290%	155%	380%	203%
355					196%		196%		257%		338%	181%
400									229%		300%	160%
450									203%		267%	
500											240%	
560											215%	
630											191%	
710												

Model **MEdsoftstart/I03** is rated at 600A continuous current and can be used at 1440A starting current for normal duty and at 750A starting current for heavy duty applications. MEdsoftstart/I03 can be ordered for voltage ranges from 400Vac to 690Vac and can be ordered with a built-in bypass contactor or can be used with an external bypass contactor, or without a bypass contactor.

Model: **MEdsoftstart/I03**

Continuous rated current: 600A

Max. starting current: 1440A Normal duty

Max starting current: 750A Heavy Duty

Table 4: MSoftstart/I03 guideline for motor sizes¹

Motor Size [kW]	MSoftstart/I03 Normal 3-wire circuit						MSoftstart/I03 6-wire inside delta circuit					
	400Vac Supply Voltage		525Vac Supply Voltage		690Vac Supply Voltage		400Vac Supply Voltage		525Vac Supply Voltage		690Vac Supply Voltage	
	Normal Duty	Heavy	Normal Duty	Heavy	Normal Duty	Heavy	Normal Duty	Heavy	Normal Duty	Heavy	Normal Duty	Heavy
75		551%										
90		460%		605%								
110		377%		493%				647%		647%		
132	603%	314%		412%				540%		540%		
160	498%	260%		655%		341%		446%		586%		
200	399%	208%		524%		273%		686%		357%		615%
250	319%	166%		419%		218%		550%		286%		493%
315	253%			332%		173%		436%		227%		391%
355				295%		154%		387%		202%		667%
400				262%				344%		179%		347%
450								306%		159%		309%
500								275%				275%
560								246%				247%
630										245%		247%
710										322%		221%
800										286%		196%
900										254%		174%
1000												154%
1120												264%

Model **MSoftstart/I04** is rated at 900A continuous current and can be used at 1600A starting current for normal duty and at 900A starting current for heavy duty applications. MSoftstart/I04 can be ordered for voltage ranges from 400Vac to 690Vac and can be used with an external bypass contactor, or without a bypass contactor.

Model: **MSoftstart/I04**

Continuous rated current: 900A
 Max. starting current: 1600A Normal duty
 Max starting current: 900A Heavy Duty

⚠ Note: a built-in bypass contactor option is **not** available with model MSoftstart/I04.

Table 5: MSoftstart/I04 guideline for motor sizes¹

Motor Size [kW]	MSoftstart/I04 Normal 3-wire circuit						MSoftstart/I04 6-wire inside delta circuit					
	400Vac Supply Voltage		525Vac Supply Voltage		690Vac Supply Voltage		400Vac Supply Voltage		525Vac Supply Voltage		690Vac Supply Voltage	
	Normal Duty	Heavy	Normal Duty	Heavy	Normal Duty	Heavy	Normal Duty	Heavy	Normal Duty	Heavy	Normal Duty	Heavy
75		662%										
90		552%										
110		452%		592%								
132	669%	377%		495%				647%		647%		
160	554%	311%		409%				536%		536%		
200	443%	249%		582%		327%		429%		563%		
250	354%	199%		465%		262%		611%		344%		592%
315	281%	158%		369%		207%		485%		273%		469%
355	250%			328%		184%		430%		242%		417%
400	222%			291%		164%		382%		215%		370%
450	197%			258%				340%		191%		330%
500	177%			233%				306%		172%		296%
560				208%				273%		154%		265%
630				185%				243%				235%
710								215%				209%
800								191%				185%
900										251%		165%
1000										223%		148%
1120										201%		
1400										179%		
1500												188%

1.1.2 Typical operating temperature

The operating temperature is determined by the typical ambient temperature in the immediate vicinity of the soft starter, air flow through the soft starter and cooling mechanisms that are used, as well as the soft starter workload. Refer par 2.2.3 for a description of how the cabinet design can also be used to best regulate operating temperature.

De-rate the soft starter starting capacity at 1.4% per °C for higher temperatures above 50°C.

Example of temperature de-rating:

The requirement is for a 75kW 400Vac motor (normal, 3-wire connected) in a heavy duty application, to operate in an environment where the operating temperature is likely to be 60°C. From Table 2, the motor's FLC = 136A (at 0.8 power factor), while the MEdsoftstart/I01 model soft starter can provide a maximum starting current of 184% (or 250A) if operated below 50°C.

*These values should be de-rated for operation at 60°C i.e. $(60^{\circ}\text{C} - 50^{\circ}\text{C}) * 1.4\% = 14\%$, thus $184\% - 14\% = 170\%$ (or 231A).*

If this is insufficient for the application, then more robust selection for this application may be MEdsoftstart/I02 with a de-rated starting current of $287\% - 14\% = 273\%$ (or 371A) – see Table 3.

1.1.3 Soft starter workload

Soft starter workload is made up of the starting time, stopping time and number of starts per hour, as well as any run time when a bypass contactor is not used. If the expected work load is high, a soft starter with a larger current margin should be selected.

If the expected starting time is longer than 30 seconds, a higher rated soft starter should be selected. If the application requires frequent starts with short running time, select a soft starter from the heavy duty columns.

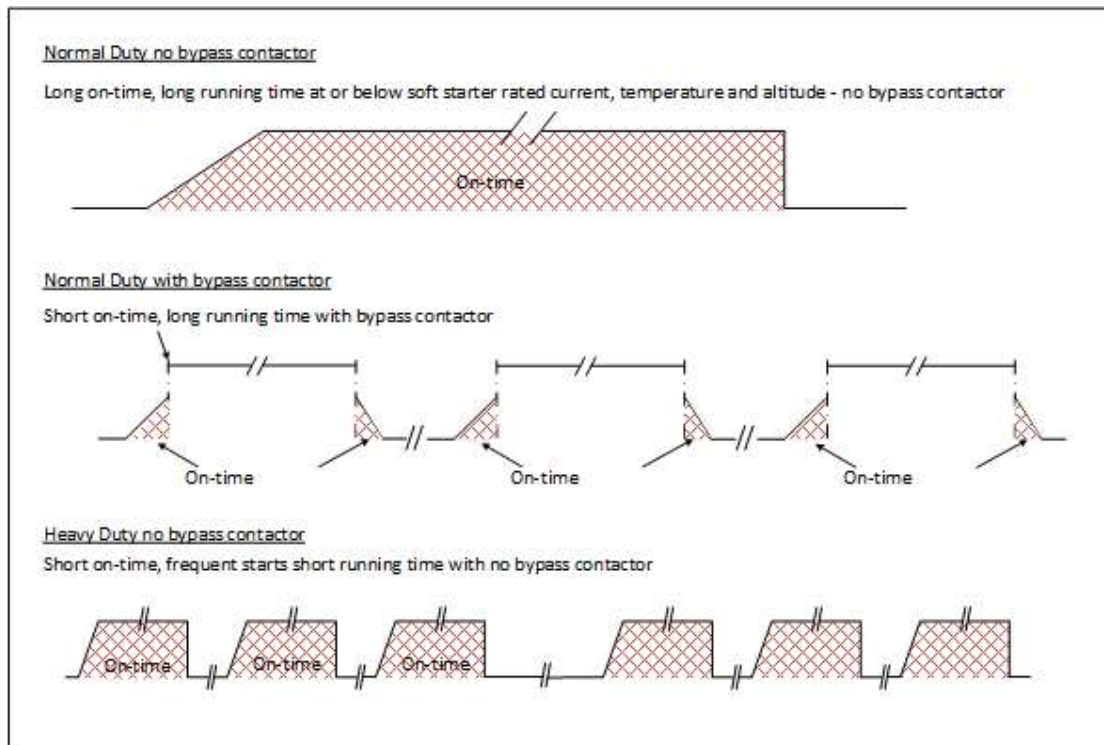

Figure 1 –Normal and Heavy duty applications as defined by soft starter on-time

1.1.4 Altitude of installation.

The MEsoftstart range of soft starters are designed and tested at 1400m above sea level. When planning to use the soft starter at altitudes higher than 1400m the soft starter the guideline is to de-rate at 0.67% per 100m for higher altitudes.

1.1.5 Selection example

1. The application is a fan in a 400V AC3 distribution, which does not require high starting torque. A normal 3-wire configuration (with bypass) 90kW fan motor is specified, with normal duty starting: Ramp-start of 20s duration, requiring no more than 200% of the motor's running current during start-up:

a) Calculations:

- Normal full-load current $= P(\text{kW}) / (\sqrt{3} \times \text{PF} \times \text{VL-L}) \times 1000$
 $= 90 / (\sqrt{3} \times 0.8 \times 400) \times 1000$
 $= 162.4\text{A}$
- Starting current needed $= 200\% \times 162.4$
 $= 324.8\text{A}$

b) Conclusion: our starting current < 480A allowed for normal duty with MEsoftstart/I01
⇒ **Use soft starter (MEsoftstart/I01).**

2. The application is a compressor or conveyor in a 400V AC3 distribution, requiring high starting torque. The same 90kW motor – this time driving a compressor motor – is specified (with bypass), with heavy duty starting: slow ramp longer than 30s duration and approximately 400% of the motor's running current during start-up:

a) Calculations:

- Here, starting current needed $= 400\% \times 162.4$
 $= 649.6\text{A}$

b) Conclusion: our starting current >250A allowed for heavy duty with MEsoftstart/I01. Looking at MEsoftstart/I02, its heavy duty starting current of 390A is also too low, i.e. MEsoftstart/I03 with a heavy duty starting current of 900A would suffice.
⇒ **Use soft starter (MEsoftstart/I03).**

1.2 Checking the Product when unpacking

Unpack the product and check the label on the soft starter to ensure that the model agrees with the order and that the product is intact. Figure 2 shows product labels for the MEsoftstart/I01 and MEsoftstart/I02 models. From the label can be seen the rated continuous current of the MEsoftstart soft starter, as well as the maximum starting current for normal duty. The rated supply voltage is also visible on the label.

Note that the labels in Figure 2 are both labels for MEsoftstart models without built-in bypass contactors. This can be seen from the grid side and motor side bypass terminal markings on the label.

Recommended motor sizes are shown on the label. These motor sizes are applicable for normal 3-wire installation. Also refer to the tables in paragraph 1.1.1 for more information about the supported motor sizes.

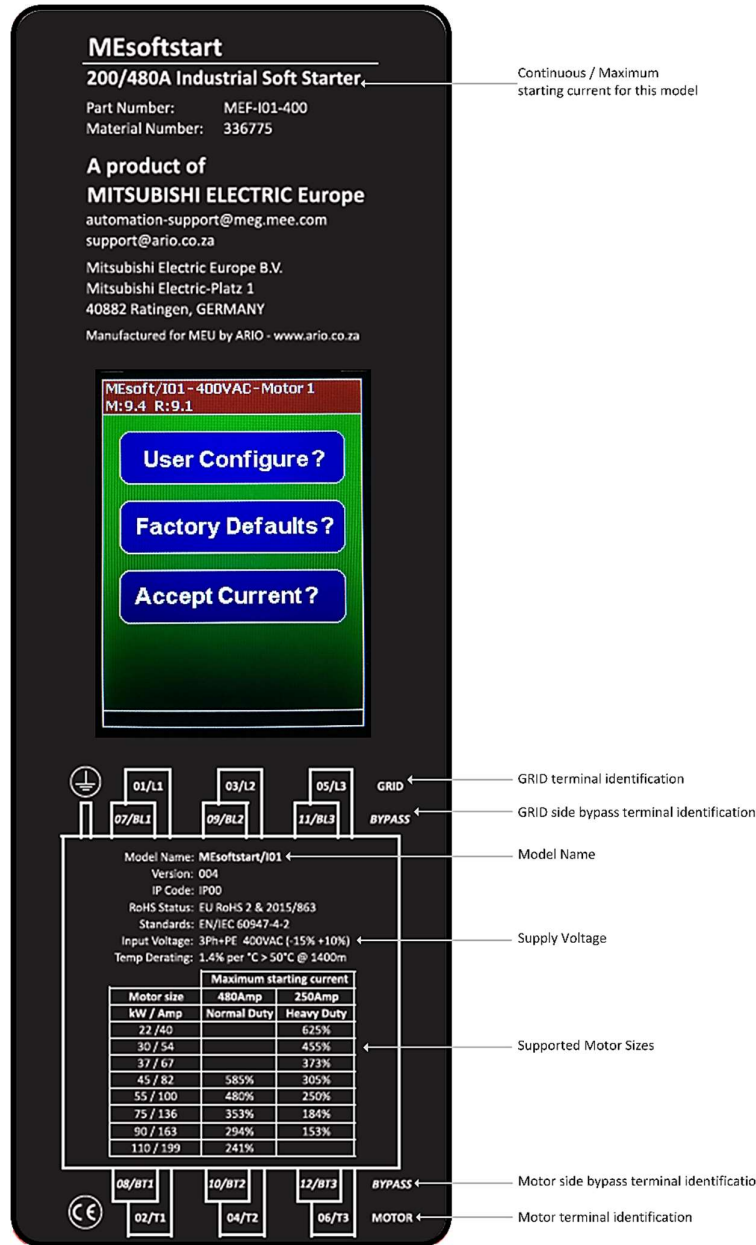

Figure 2 – Product marking

1.3 Component and Terminal identification

Component and terminals are identified in Figure 3 and Table 6 below. Comparable markings are used on all other models.

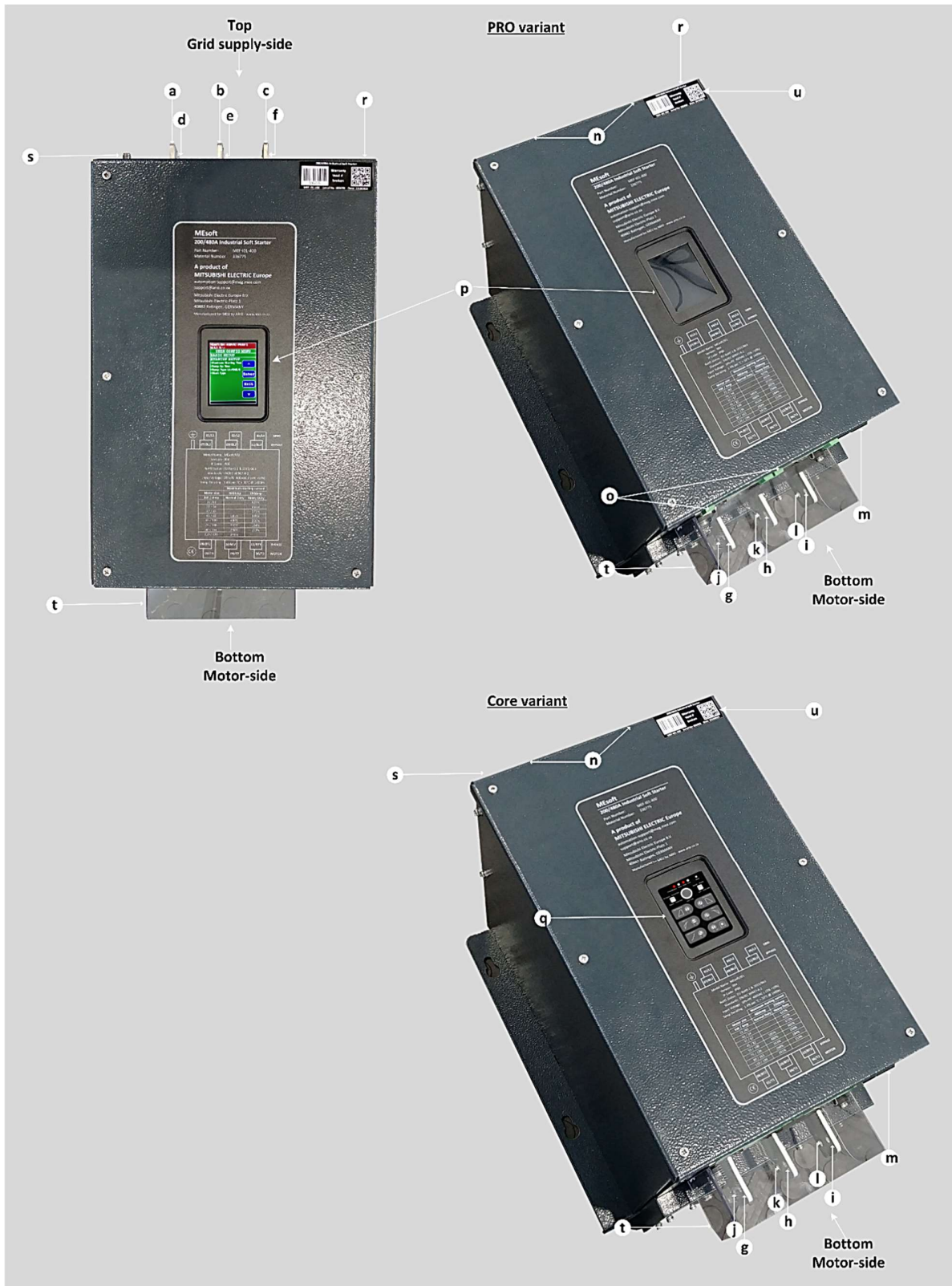

Figure 3 – Soft starter terminal and component identification

Table 6: List of components and terminals

Symbol	Name	Description	Notes	Ref
a)	Busbar 1 / L1	Grid supply L1		3.2.1
b)	Busbar 3 / L2	Grid supply L2		
c)	Busbar 5 / L3	Grid supply L3		
d)	Busbar 7 / BL1	Supply L1 to bypass contactor L1	Only on models without internal bypass contactor	
e)	Busbar 9 / BL2	Supply L2 to bypass contactor L2		
f)	Busbar 11 / BL3	Supply L3 to bypass contactor L3		
g)	Busbar 2 / T1	Motor phase U		
h)	Busbar 4 / T2	Motor phase V		
i)	Busbar 6 / T3	Motor phase W		
j)	Busbar 8 / BT1	Bypass contactor supply L1 to motor T1	Only on models without internal bypass contactor	
k)	Busbar 10 / BT2	Bypass contactor supply L2 to motor T2		
l)	Busbar 12 / BT3	Bypass contactor supply L3 to motor T3		
m)	RJ 45 (x 2)	Two RS485 to MEssoftstart PC App / Modbus RTU interface	Two ports of the same Modbus port for easy daisy-chaining	7
n)	10 Pin Wiring terminal connector (x2)	Green Wiring terminals on top side		3.2.4 3.2.5
o)	10 Pin Wiring terminal connector (X2)	Green Wiring terminals on bottom side	Only on Pro variants	3.2.4
p)	TFT touchscreen	TFT touchscreen for monitoring and controlling the soft starter	Only on Pro variants	6
q)	HMI panel	Potentiometer HMI panel	Only on Core variants	5
r)	RJ 45	TCP to MEssoftstart PC App / Modbus TCP interface	Only on Pro variants	7.2
s)	Earthing stud	Chassis ground		3.2.2
t)	Protective cover	Finger guard for terminals		3.2.3
u)	Warranty label	Do not remove this label. The warranty is void if the label is removed or damaged		

2. INSTALLATION INSTRUCTIONS

This chapter explains the installation of the MEsoftstart/I00, MEsoftstart/I01, MEsoftstart/I02, MEsoftstart/I03 and MEsoftstart/I04 model soft starters. Note that for safety reasons, it is important to install the soft starter in a cabinet or enclosure where the terminals will not pose a hazard to personnel. This section shows how to safely install the soft starter and provides guidelines for the selection or design of a suitable motor control centre cabinet / enclosure.

⚠ Always read the instructions before installing, connecting and using the equipment.

2. INSTALLATION INSTRUCTIONS	17
2.1 PREPARING FOR SOFT STARTER INSTALLATION	18
2.2 MOTOR CONTROL CENTRE CABINET DESIGN	23
2.3 SOFT STARTER INSTALLATION	27

2.1 Preparing for soft starter installation

The peripheral devices that are needed around the soft starter need to be specified before planning the installation of the soft starter.

The soft starter can be wired to start a normal 3-wire motor or inside-delta on a six-wire motor. The installation and wiring of the soft starter is similar for the normal and the inside-delta connections, but there may be implications for the enclosure size and cable length, as well as the selection of external bypass contactor for the different ways of connecting the motor.

2.1.1 Normal Delta 3-wire connection

The diagram below shows the connection diagram for the soft starter with and without built-in bypass contactor, for normal 3-wire connection. With this method of connecting the motor, the full motor starting current flows through the soft starter switching elements during start-up. After start-up and if a built-in or external bypass contactor is used, the full running current of the motor flows through the contactor. If no bypass contactor is used, the motor's continuous running current flows through the soft starter switching elements.

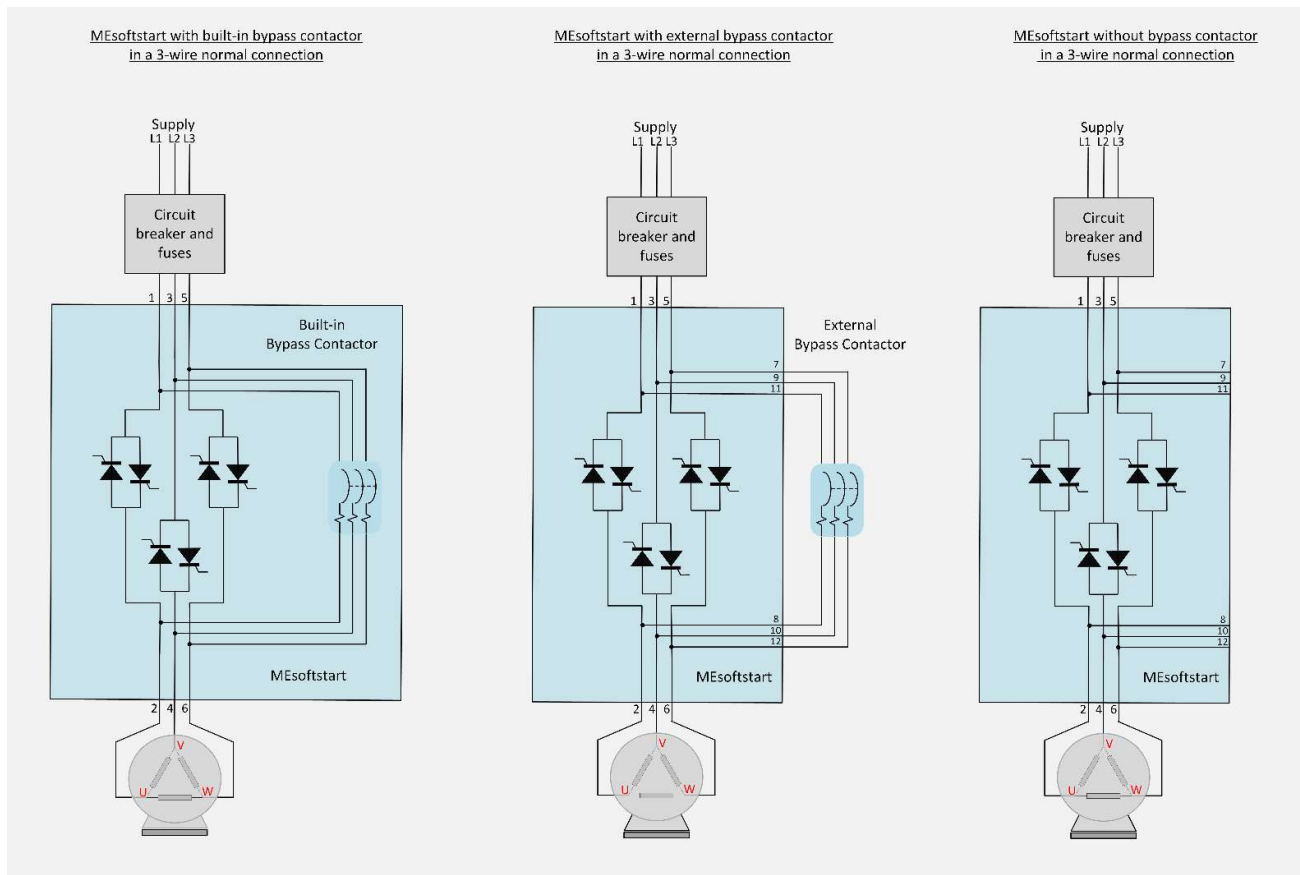

Figure 4 – Soft starter circuit diagram for 3-wire delta motor

With this method of installation, the bypass contactor must be scaled for the full running current of the motor. Only three cables are needed to run the distance to the motor.

2.1.2 Inside-delta 6-wire connection

The diagram below shows the connection diagram for the soft starter with and without built-in bypass contactor, for an inside-delta 6-wire connection. With this method of connecting the motor, 58% of the motor's starting current flows through the soft starter switching elements during the start-up ramp. After start-up and if a built-in or external bypass contactor is used, 58% of the running current of the motor flows through the bypass contactor. If no bypass contactor is used, 58% of the motor's continuous running current flows through the soft starter switching elements.

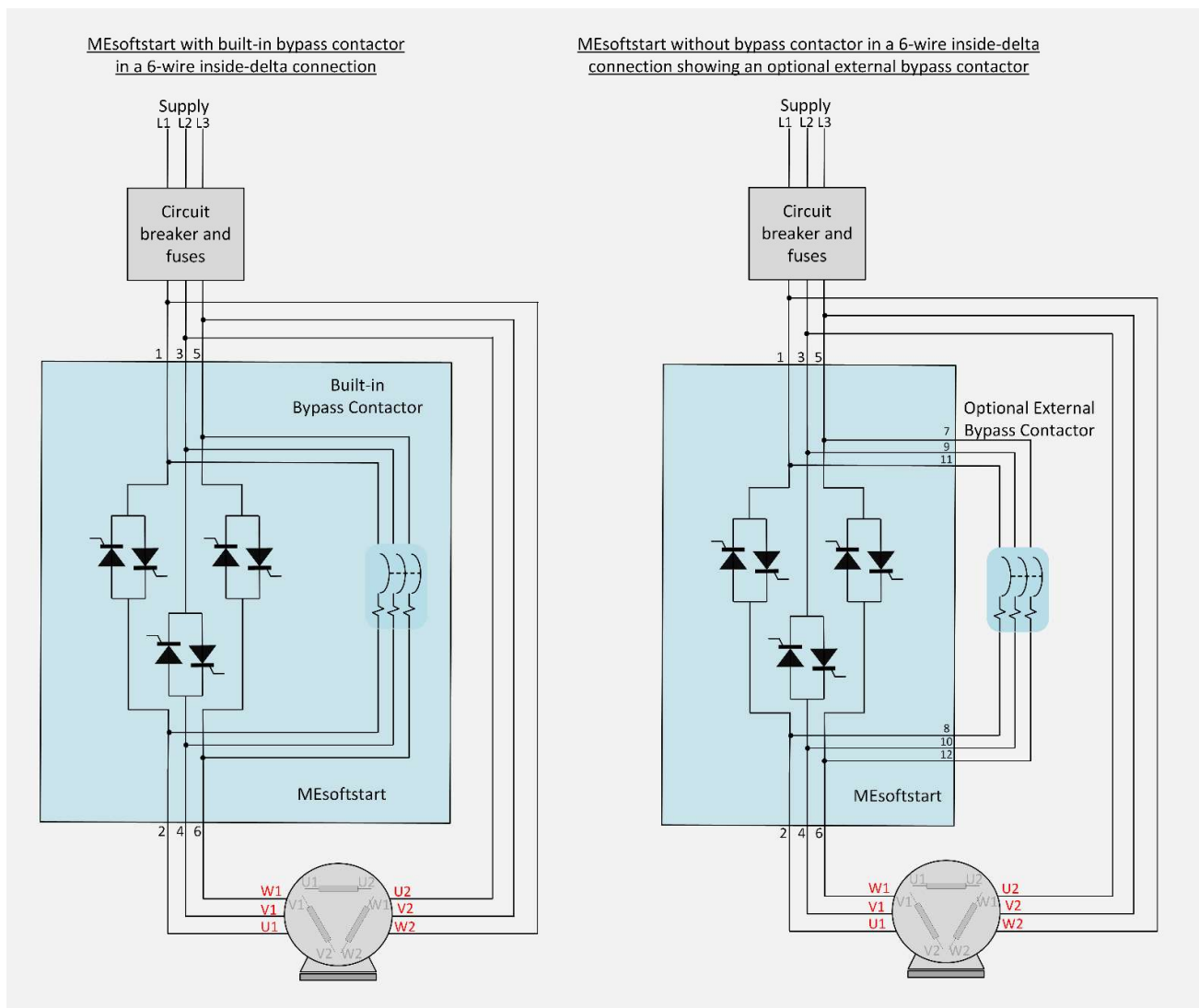
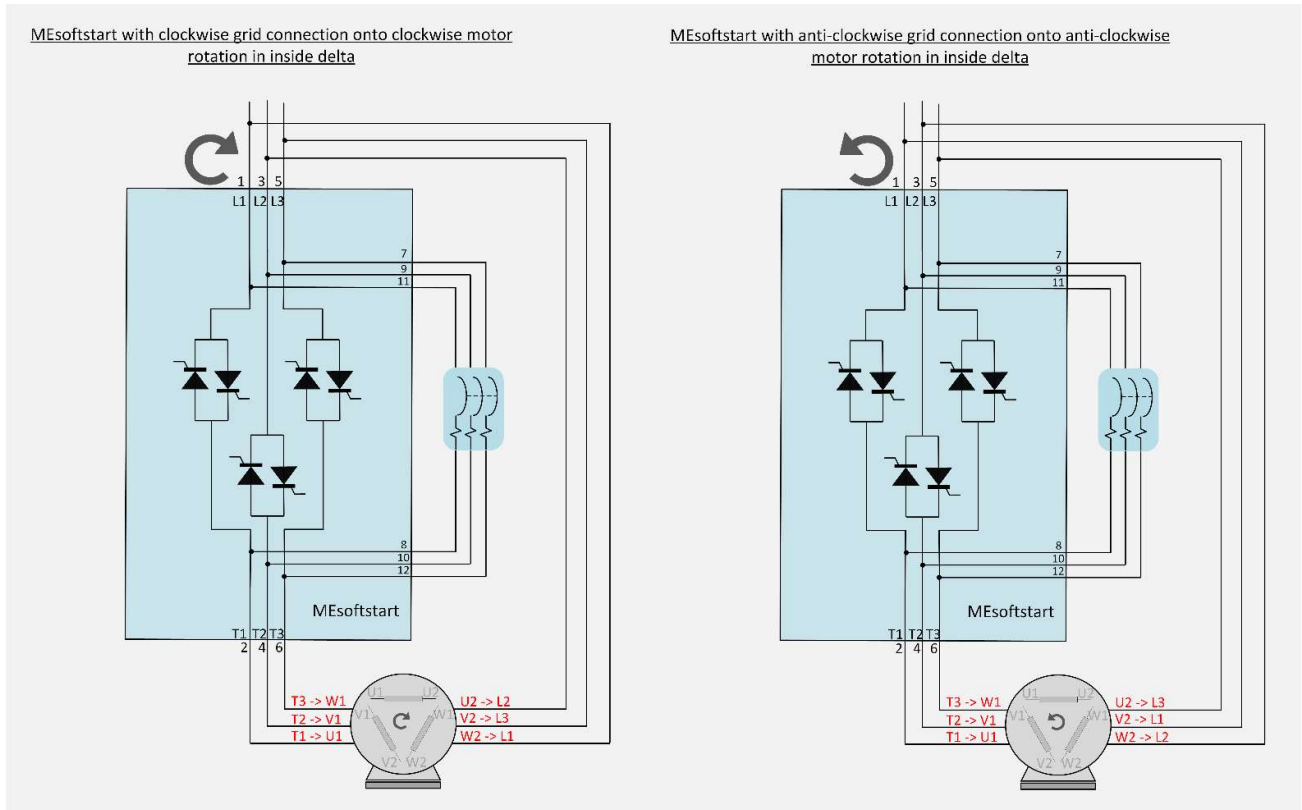

Figure 5 – Soft starter circuit diagram for 6-wire inside-delta motor

- ⚠ Ensure to connect the grid-side terminals of the inside-delta motor to the soft starter L1, L2, L3 terminals. Incorrectly connecting them to the Bypass terminals may damage the soft starter. Refer Figure 19.
- ⚠ Note that for inside delta wiring the Earthing Leakage protection is not active.

Take special note of the wiring of an inside delta motor when the grid connection on the soft starter is clockwise or anti-clockwise. Refer to Figure 6 to understand the difference.



2.1.3 Soft starter and Peripheral devices

⚠ Always check the nameplate information on your motor before designing the peripheral devices

Figure 7 shows the MSoftstart/I01 Core model soft starter and the associated peripheral devices. The installation for the other MSoftstart models will be the same.

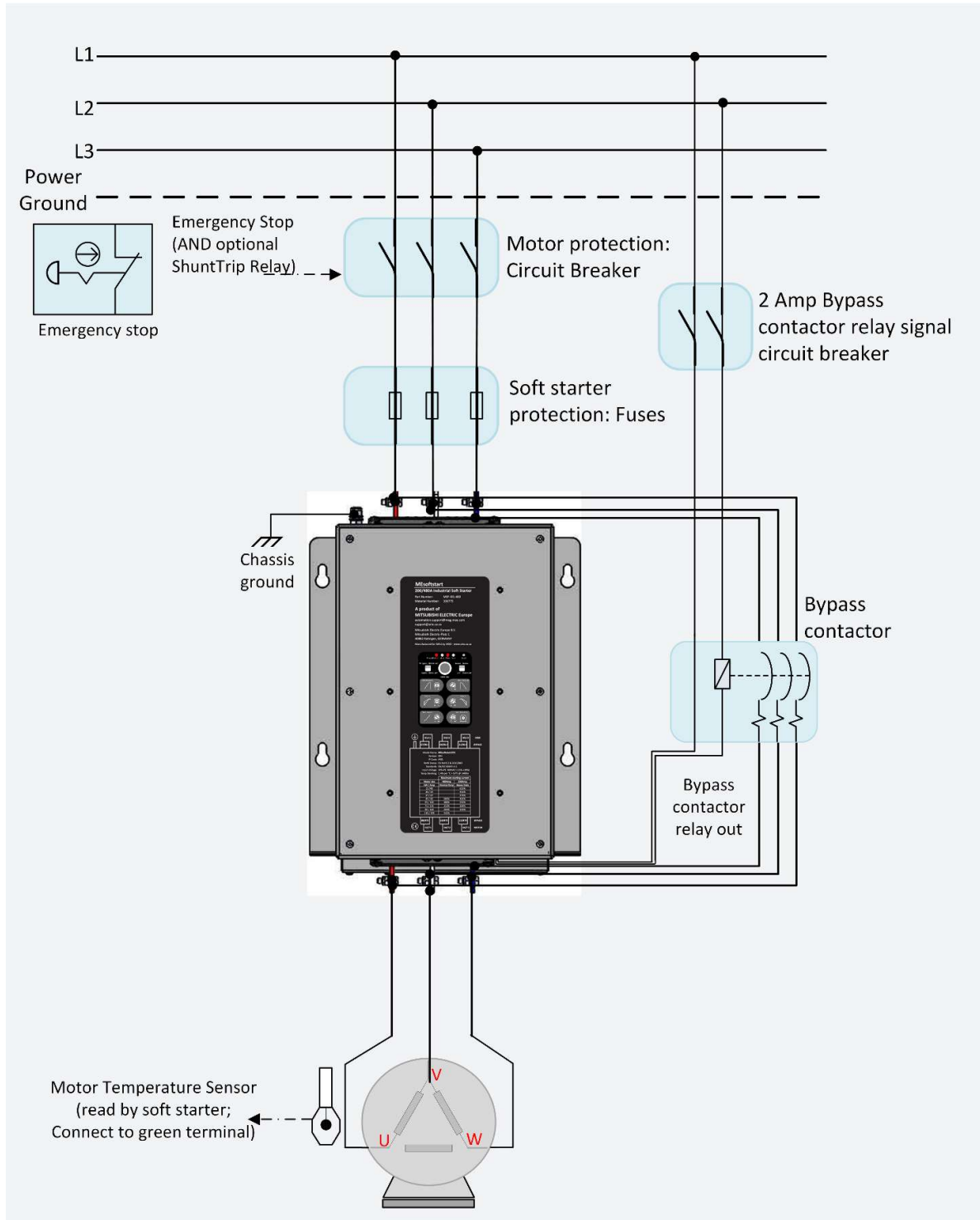

Figure 7 – Soft starter circuit diagram with peripheral devices

The items in Figure 7 are further described in Table 7 below.

Table 7: Peripheral devices in the soft starter installation

Item	Name	Description	Refer																														
1.	Soft starter (MEsoftstart/I00, MEsoftstart/I01, MEsoftstart/I02, MEsoftstart/I03, MEsoftstart/I04)	The MEsoftstart soft starter connects to the supply voltage on the top side and to the motor on the bottom side.	Figure 3																														
2.	Moulded case circuit breaker (MCCB)	The circuit breaker must be selected according to the maximum current of the motor. The circuit breaker should ideally be controllable from an Emergency Stop button and the soft starter Shunt Trip Relay.	-																														
3.	Fuses	The fuses are required to protect the soft starter SCRs against excessive currents. The fuses should ideally be in line between the circuit breaker and the soft starter and outside the delta for 6-wire installations. The fuses should be selected as follows for the different MEsoftstart models:	Figure 5																														
		<table border="1"> <thead> <tr> <th>Model</th> <th>Minimum Fuse current</th> <th>Max I²t rating</th> <th>Recommended Mersen² Fuse</th> <th>30 sec rating @ 690V</th> </tr> </thead> <tbody> <tr> <td>MEsoftstart/I00</td> <td>160A</td> <td>6050</td> <td>pc31ud69v160tf</td> <td>330A</td> </tr> <tr> <td>MEsoftstart/I01</td> <td>315A</td> <td>125000</td> <td>pc30ud69v315tf</td> <td>750A</td> </tr> <tr> <td>MEsoftstart/I02</td> <td>500A</td> <td>322000</td> <td>pc31ud69v500tf</td> <td>1300A</td> </tr> <tr> <td>MEsoftstart/I03</td> <td>900A</td> <td>1330000</td> <td>pc33ud69v900tf</td> <td>2890A</td> </tr> <tr> <td>MEsoftstart/I04</td> <td>1000A</td> <td>1330000</td> <td>pc33ud69v1000tf</td> <td>3200A</td> </tr> </tbody> </table>		Model	Minimum Fuse current	Max I ² t rating	Recommended Mersen ² Fuse	30 sec rating @ 690V	MEsoftstart/I00	160A	6050	pc31ud69v160tf	330A	MEsoftstart/I01	315A	125000	pc30ud69v315tf	750A	MEsoftstart/I02	500A	322000	pc31ud69v500tf	1300A	MEsoftstart/I03	900A	1330000	pc33ud69v900tf	2890A	MEsoftstart/I04	1000A	1330000	pc33ud69v1000tf	3200A
		Model		Minimum Fuse current	Max I ² t rating	Recommended Mersen ² Fuse	30 sec rating @ 690V																										
		MEsoftstart/I00		160A	6050	pc31ud69v160tf	330A																										
		MEsoftstart/I01		315A	125000	pc30ud69v315tf	750A																										
		MEsoftstart/I02		500A	322000	pc31ud69v500tf	1300A																										
MEsoftstart/I03	900A	1330000	pc33ud69v900tf	2890A																													
MEsoftstart/I04	1000A	1330000	pc33ud69v1000tf	3200A																													
4.	Bypass contactor <i>(Only applicable to MEsoftstart models without built-in bypass contactor)</i>	Installed to run the motor when at full speed. The 'BYPASS CONTACTOR' discrete output signal (refer Table 13) from the soft starter should be used to control the bypass contactor. Select the bypass contactor according to the maximum running current of the motor as indicated on the motor manufacturer's label. If the motor is wired in an inside-delta circuit, the bypass contactor may be selected to be 58% of the motor rated running current. Refer to Mitsubishi Electric's non-reversing Magnetic Contactors.	Figure 25																														
5.	Bypass contactor relay circuit breaker <i>(Only applicable to MEsoftstart installations with external bypass contactor)</i>	This circuit breaker is a 2A circuit breaker protecting the Soft starter output signal that activates the external Bypass contactor via a 50/60Hz coil. The contactor coil is powered from the supply voltage and should be selected according to the supply voltage																															
6.	Emergency stop	A STOP button that will open the MCCB to disconnect all power to the soft starter and motor.	-																														
7.	Motor Temperature Sensor	The motor temperature sensor is read by the soft starter. The soft starter uses this reading to protect the motor from overheating.	-																														
8.	Induction motor	Configured as a 3-wire motor for normal delta connection or 6-wire for inside delta wiring.	-																														

2.1.4 Capacitors for power factor improvement

Capacitors for power factor improvement must not be connected on the output of the soft starter (between the soft starter and the motor). If power factor correction is required, add the capacitors on the grid-side of the soft starter.

² Mersen is a tradename of Mersen S.A. headquarted in France.

2.2 Motor control centre cabinet design

A soft starter unit uses semiconductor devices. To ensure reliable operation and long service lifetime for the soft starter, it is important to operate the soft starter in the ambient environment that complies with the equipment specifications.

When designing or selecting a soft starter cabinet, the structure, size and device layout inside the cabinet should be determined by considering issues such as:

- Safe and easy access for wiring;
- Safe and easy access to the HMI for configuring and monitoring;
- Heat generation and cooling of the soft starter;
- Peripheral devices that need to be in the cabinet and
- The operating environment.

2.2.1 Minimum cabinet size

The minimum cabinet size should be decided upon by considering the following:

- a) The circuit layout with peripheral devices (refer par 2.1);
- b) The installation environment (refer paragraph 2.2.2);
- c) Air flow requirements of the soft starter (refer par 2.3.3);
- d) Cooling requirements inside the cabinet (refer paragraph 2.2.3);
- e) Minimum space required around the soft starter (refer par 2.3.3).

2.2.2 Soft starter installation environment

The following table lists the standard specifications of the soft starter installation environment.

Table 8: Soft starter environmental specification

Environmental parameter	Model	Specification	Notes
Surrounding Air temperature	MEsoftstart/I00 MEsoftstart/I01 MEsoftstart/I02 MEsoftstart/I03 MEsoftstart/I04	-10°C to +60°C	Measurement position 5 cm from the soft starter inside the closed cabinet De-rate above 50°C at 1.4% per °C
Relative humidity		< 85%	Ideally < 50% @ 50° to < 85% @20°C
Storage temperature		-30°C to +70°C	
Atmosphere		Indoors - free from corrosive gas, flammable gas, oil mist, dust and dirt	
Altitude		1400 m above sea level.	For the installation at an altitude above 1400m de-rate the rated current of the soft starter at 0.67% per 100 m
Vibration		0.02g ² /Hz from 10 to 50Hz, reducing linearly on a log-linear plot to 0.0001g ² /Hz at 500Hz. (directions of X, Y, Z axes)	Road transport vibration only

Using the soft starter in an environment that does not satisfy these conditions, will deteriorate its performance, shorten its life span and can lead to failure. The following paragraphs contain suggested measures to ensure that the environment complies with the specification.

2.2.2.1 Temperature

For the MEsoftstart range of soft starters, the permissible surrounding air temperature of the soft starter is between -10°C and +60°C. Always operate the soft starter within this temperature range. Operation outside this range will considerably shorten the service lives of the semiconductors, parts, capacitors and other electronics. Take the following measures to keep the surrounding air temperature of the soft starter within the specified range.

(a) Measures against high temperature

- Use a forced ventilation system or similar cooling system. (Refer to par 2.2.3 on page 26.)
- Install the cabinet in an air-conditioned chamber.
- Block direct sunlight.
- Provide a shield or similar plate to avoid direct exposure to the radiated heat and wind of a heat source.
- Ventilate the area around the cabinet well.

(b) Measures against low temperature

- Provide a space heater in the cabinet.
- Do not power OFF the soft starter. (Keep the motor start signal of the soft starter OFF.)

(c) Sudden temperature changes

- Select an installation place where temperature does not change suddenly.
- Avoid installing the soft starter near the air outlet of an air conditioner.
- If temperature changes are caused by opening/closing of a door, install the soft starter away from the door.

2.2.2.2 Humidity

Operate the soft starter within the specified ambient air humidity. Too high humidity will pose problems of reduced insulation and metal corrosion. On the other hand, too low humidity is conducive to the build-up of static electricity and may cause dielectric breakdown in solid state devices.

(a) Measures against high humidity

- Seal the cabinet and provide it with a hygroscopic agent.
- Provide dry air into the cabinet from outside.
- Provide a space heater in the cabinet.

(b) Measures against low humidity

- Air with proper humidity can be blown into the cabinet from outside. Also, when installing or inspecting the unit, discharge your body (static electricity) beforehand.

(c) Measures against condensation

Condensation may occur if the cabinet temperature changes suddenly or if the outside air temperature changes suddenly. Condensation causes faults such as reduced insulation and corrosion.

- Take the measures against high humidity in (a) above.
- Do not power OFF the soft starter.

2.2.2.3 Dust, dirt, oil mist

Dust and dirt may cause such faults as poor contacts, reduced insulation and cooling effect due to the moisture-absorbed accumulated dust and dirt and in-cabinet temperature rise due to a clogged filter. In an atmosphere where conductive powder floats, dust and dirt may cause such faults as malfunction, deteriorated insulation and short circuit in a short time.

Since oil mist may cause similar conditions, it is necessary to take adequate measures.

Countermeasures:

- Place the soft starter in a totally enclosed cabinet.
- Take measures if the in-cabinet temperature rises. (Refer to paragraph 2.2.2.1)
- Purge air.
- Pump clean air from outside to make the in-cabinet air pressure higher than the outside air pressure.

2.2.2.4 Corrosive gas, salt damage

If the soft starter is exposed to corrosive gas or to salt (e.g. near the sea), the printed circuit board and components will corrode, the relays and switches can deteriorate resulting in unreliable contact.

When it is required to operate the soft starter in this environment, take the measures suggested in the paragraph 2.2.2.3.

2.2.2.5 Explosive, flammable gases

It is not recommended to install and use the soft starter in an environment where flammable gasses are present. The soft starter is not explosion proof and it will have to be contained in a certified explosion-proof cabinet. If possible, avoid installation in such environments and install the soft starter in a non-hazardous place.

2.2.2.6 High altitude

The soft starter may be used at its recommended current rating, at altitudes lower than 1400m above sea-level. For the installation at an altitude above 1400 m, de-rate the rated current of the soft starter at 0.67% per 100 m.

If it is used at a higher altitude than 2500m above sea level, thin air will reduce the cooling effect and low air pressure will deteriorate dielectric strength and a higher rated soft starter model should be selected.

2.2.2.7 Vibration, impact

The soft starter is not designed to withstand periods of high vibration or high impact. The vibration resistance of the soft starter vibration spectrum is tested at $0.02g^2/Hz$ from 10 to 50Hz, reducing linearly on a log-linear plot to $0.0001g^2/Hz$ at 500Hz for the directions of X, Y, Z axes. Applying vibration and impacts for a long time may loosen the structures and cause poor contacts of connectors, even if those vibration and impacts are within the specified values. (Refer to IEC 60068-2-6).

Especially when impacts are applied repeatedly, caution must be taken because such impacts may break the installation feet.

Countermeasures:

- Provide the cabinet with rubber vibration isolators.
- Strengthen the structure to prevent the cabinet from resonance.
- Install the cabinet away from the sources of the vibration.

2.2.3 Cooling system types for soft starter cabinet

The heat that the soft starter and other equipment (transformers, lamps, resistors, etc.) generates, as well as any incoming heat (such as direct sunlight) must be dissipated to keep the temperature inside the cabinet lower than the permissible operating temperature of the soft starter.

When selecting or designing a cabinet for the soft starter, the following cooling considerations (for the cabinet) must be considered:

The cooling systems are classified as follows in terms of the cooling calculation method.

- (a) Cooling by natural heat dissipation from the cabinet surface (totally enclosed type).
- (b) Cooling by heatsink (e.g. aluminium fin).
- (c) Cooling by ventilation (forced ventilation type, pipe ventilation type).
- (d) Cooling by heat exchanger or cooler (e.g. heat pipe, cooler).

Table 9: Cooling systems for soft starter cabinet

Cooling system		Cabinet layout	Comment
Natural cooling	Natural ventilation (enclosed, open type)		This system is low in cost and generally used, but the cabinet size increases as the soft starter capacity increases. This system is for relatively small capacities.
	Natural ventilation (totally enclosed type)		Being a totally enclosed type, this system is the most appropriate for hostile environment having dust, dirt, oil mist, etc. The cabinet size increases depending on the soft starter capacity.
Forced cooling	Heatsink cooling		This system has restrictions on the heatsink mounting position and area. This system is for relatively small capacities.
	Forced ventilation		This system is for general indoor installation. This is appropriate for cabinet downsizing and cost reduction and often used.
	Heat pipe		This is a totally enclosed for cabinet downsizing

2.3 Soft starter installation

2.3.1 Soft starter placement

Placement of the soft starter needs careful planning. The clearance below the soft starter is required for terminal access for wiring as well as air inlet and the clearance above the soft starter is required for heat dissipation as well as terminal access for wiring. Consider the following:

- Install the soft starter securely on a sturdy horizontal or vertical surface with bolts (refer paragraph 2.3.6).
- Leave enough clearances and take measures to cool the device (refer par 2.3.3).
- Leave enough clearance to access terminals to wire the soft starter.
- Avoid places where the soft starter is subjected to direct sunlight, high temperature and high humidity (refer paragraph 2.2.2).
- Install the soft starter on a non-flammable wall surface.
- When encasing multiple soft starters, install them in parallel as a cooling measure (refer paragraph 2.3.4)
- For heat dissipation and maintenance, keep clearance between the soft starter and the other devices or cabinet surface.

2.3.2 Installation orientation of the soft starter

The MEdsoftstart models without internal bypass contactor may be mounted at any orientation, but the recommended orientation is upright against a wall or against the cabinet back or side (max. deviation from vertical is 22.5°).

This allows for easy access to the HMI, terminals and with natural air flow from bottom to top as shown in Figure 9.

If a MEdsoftstart model with an internal bypass contactor is used, the orientation guidelines in Figure 8 should be adhered to.

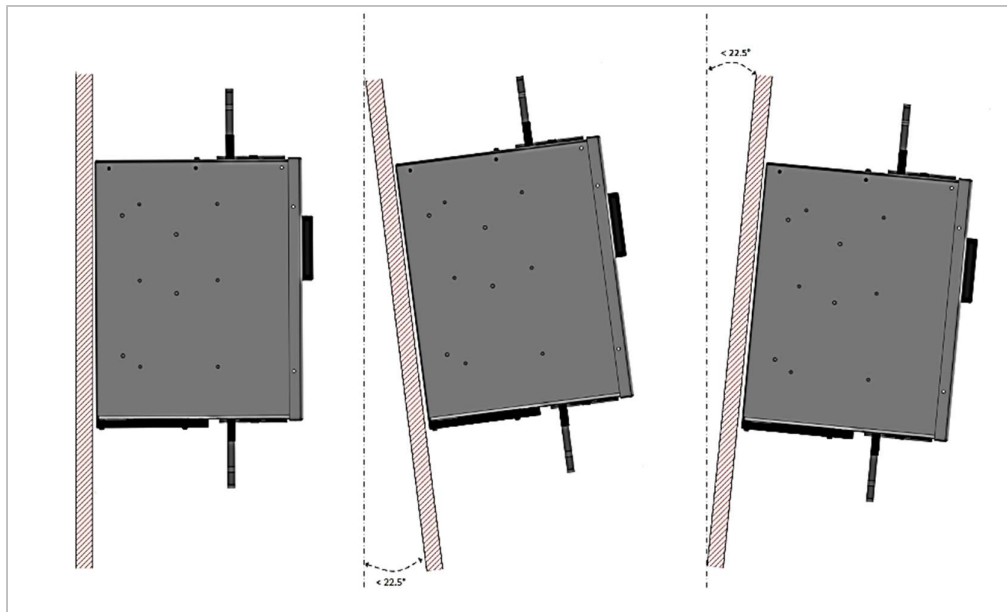

Figure 8 – Mounting orientation

2.3.3 Air flow around the soft starter

Heat is blown up from inside the soft starter by the small built-in fan. Leave space around the soft starter for ample air flow through the soft starter cabinet. Any equipment placed above the soft starter should be heat resistant.



Figure 9 – Air flow around the soft starter

2.3.4 Arrangement of multiple soft starters

When encasing multiple soft starters in the same cabinet, generally arrange them horizontally as shown in the right Figure 10 (a). When it is inevitable to arrange them vertically to minimize space, take such measures as to provide guides since heat from the bottom soft starters can increase the temperatures in the top soft starters, causing soft starter overheating.

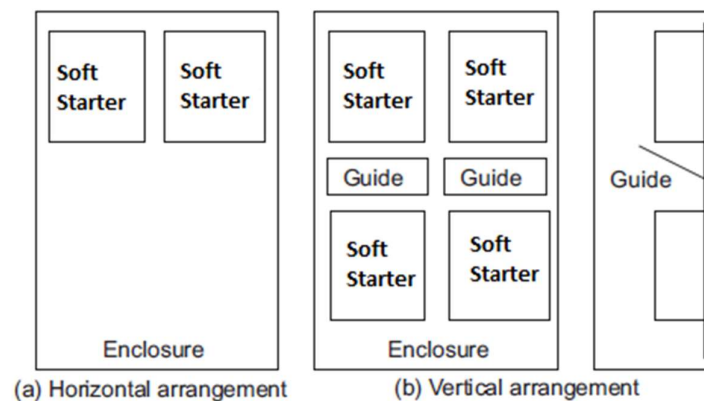

Figure 10 – Arrangement of multiple soft starters in a single cabinet

When mounting multiple soft starters, take caution not to make the surrounding air temperature of the soft starter higher than the permissible value by providing ventilation and increasing the cabinet size.

2.3.5 Arrangement of the ventilation fan and soft starter

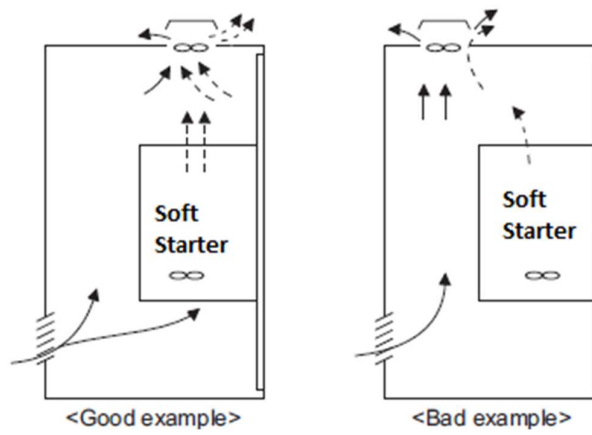

Figure 11 – Arrangement of the ventilation fan and soft starter

Heat generated in the soft starter is blown up from the bottom of the unit as warm air by the cooling fan. When installing a ventilation fan for that heat, determine the place of ventilation fan installation after fully considering air flow. (Air passes through areas of low resistance. Make an airway and airflow plates to expose the soft starter to cool air.)

2.3.6 Drilling plan for soft starter installation

When drilling mounting holes in a cabinet, take caution not to allow chips and other foreign matter to enter the soft starter. Figure 12 through Figure 18 below shows the drilling plan for mounting the MEsoftstart soft starter in a cabinet or against a wall.

2.3.6.1 MEsoftstart/I00 and MEsoftstart/I01 Drilling plan

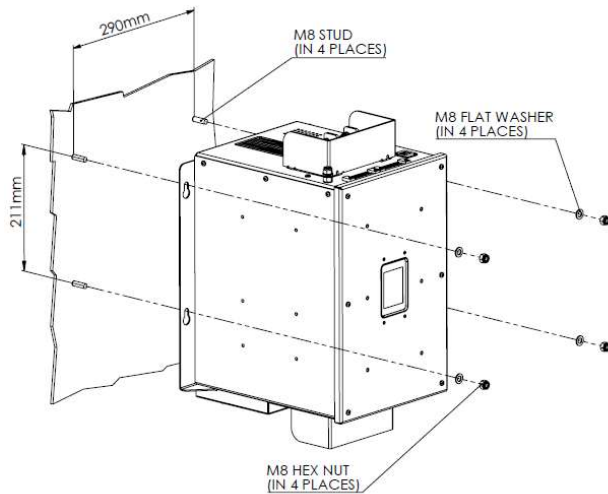

Figure 12 – Drilling plan: MEsoftstart/I00 with and without bypass contactor and MEsoftstart/I01 without bypass contactor

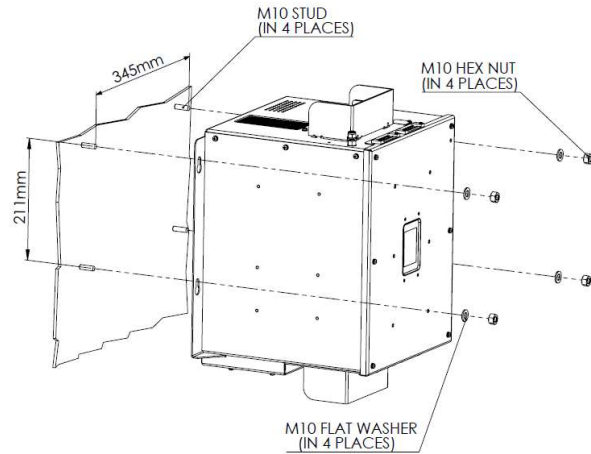

Figure 13 – Drilling plan: MEsoftstart/I01 with bypass contactor

2.3.6.2 MEsoftstart/I02 Drilling plan

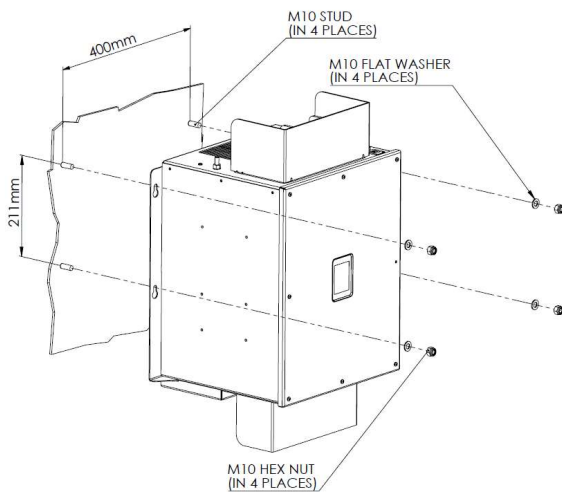

Figure 14 – Drilling plan: MEsoftstart/I02 without bypass contactor

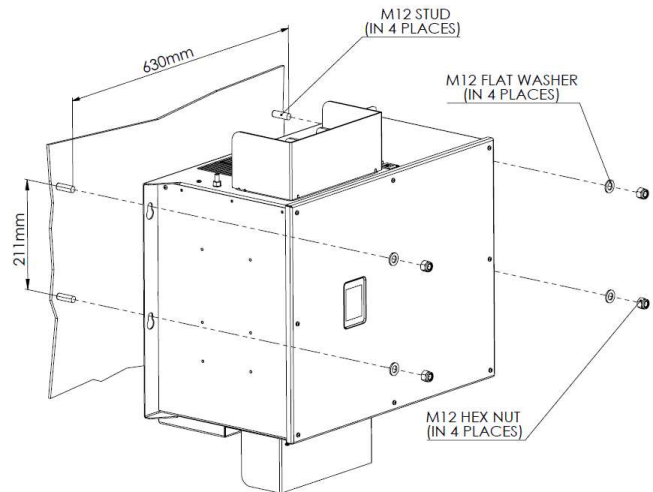

Figure 15 – Drilling plan: MEsoftstart/I02 with bypass contactor

2.3.6.3 MEsoftstart/I03 Drilling plan

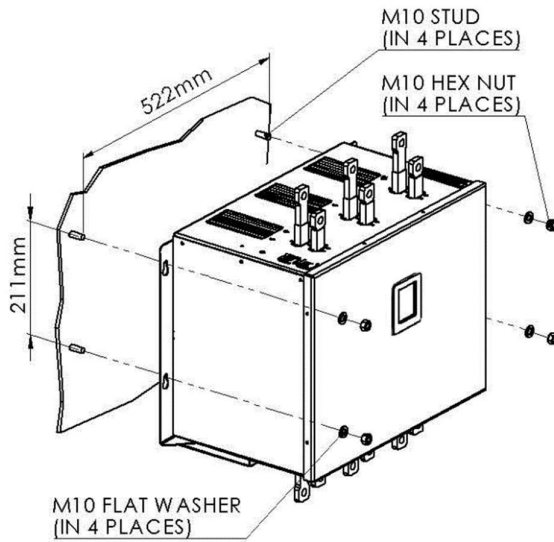

Figure 16 – Drilling plan: MEsoftstart/I03 without bypass contactor

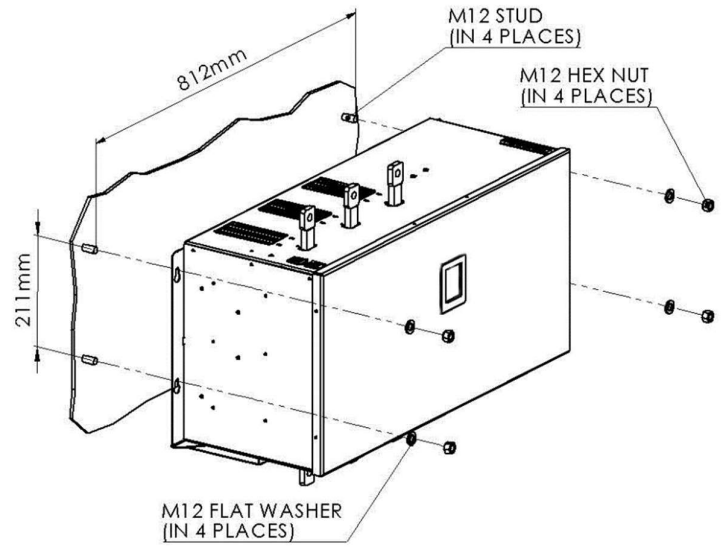

Figure 17 – Drilling plan: MEsoftstart/I03 with bypass contactor

2.3.6.4 MEsoftstart/I04 Drilling plan

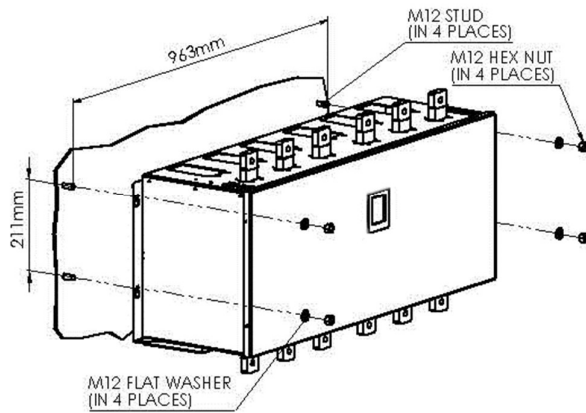

Figure 18 – Drilling plan: MEsoftstart/I03 without bypass contactor

3. WIRING

This chapter identifies the terminals and explains the wiring of the MEsoftstart/I01 and MEsoftstart/I02 models soft starter.

⚠ Always read the instructions before installing, connecting and using the equipment.

3. WIRING	32
3.1 TERMINAL IDENTIFICATION	33
3.2 WIRING INSTRUCTIONS.....	35

3.1 Terminal identification

The soft starter has grid-side and motor-side power terminals, an earthing stud. All variants have Modbus RTU cable connectors and signal terminals on green wiring terminal blocks (grid input side). The terminals are clearly marked on all MEsoftstart models.

3.1.1 Terminal identification – Pro variants

All Pro MEsoftstart variants have a Modbus TCP RJ45 terminal (grid input side) and additional signal terminals on green wiring terminal blocks. Figure 19 shows the terminals/connectors for Pro variant models MEsoftstart/I01 and MEsoftstart/I02 without built-in bypass contactor.

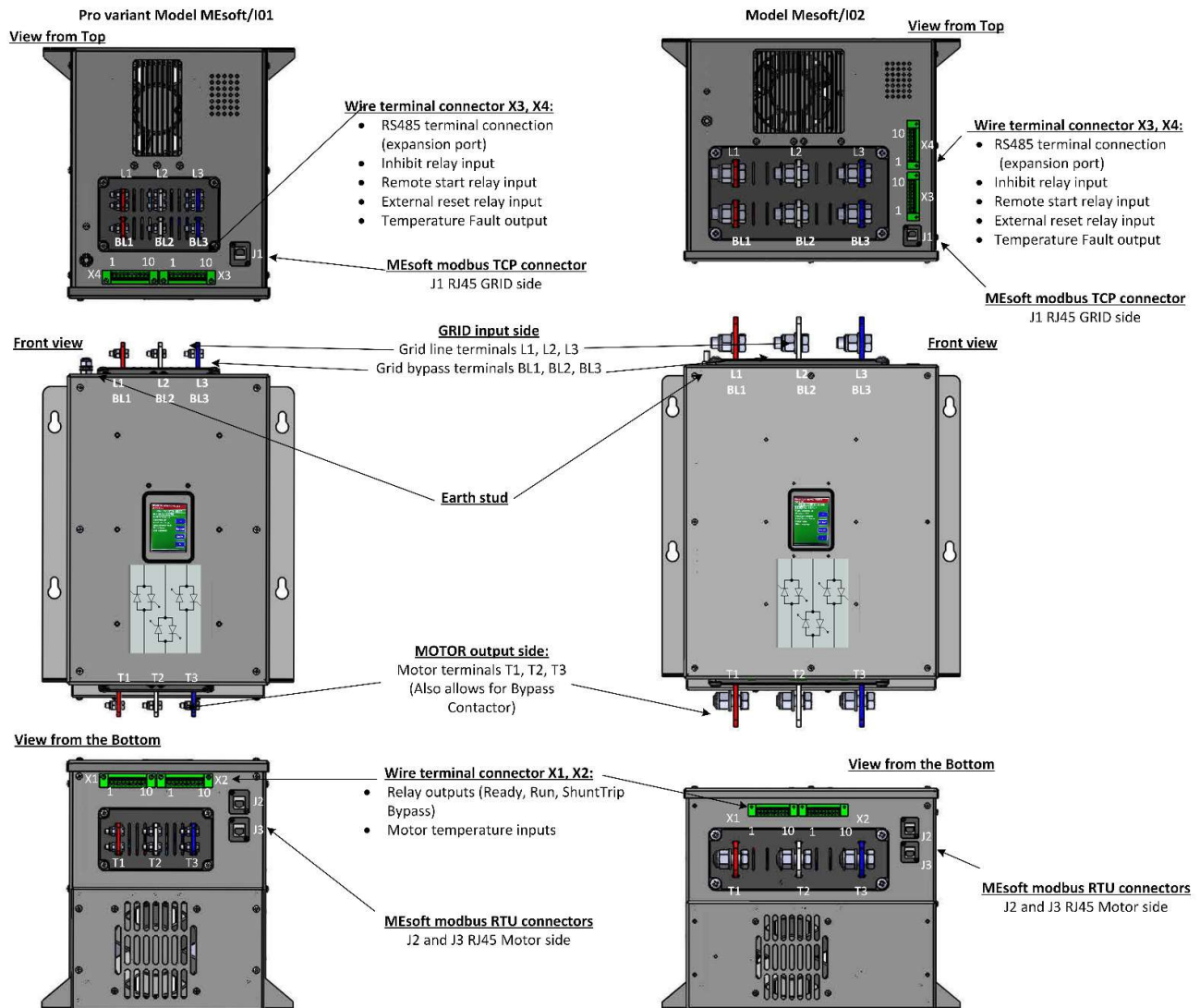

Figure 19 – Soft starter Pro variant terminal identification

3.1.2 Terminal identification – Core variants

Figure 20 shows the terminals for Core variant models MSoftstart/I00 and MSoftstart/I01 without built-in bypass contactor.

MSoftstart/I00 and MSoftstart/I01 Core variants

View from Top

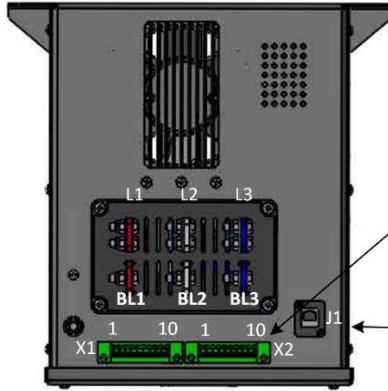

Wire terminal connector X1, X2:

- RS485 terminal connection (also on J1 RJ45)
- Remote start relay input
- External reset relay input
- Inhibit input
- Relay outputs (Ready, Bypass, Fault)
- Motor temperature input

Modbus RTU connector
J1 RJ45 for RS485 signals

Front view

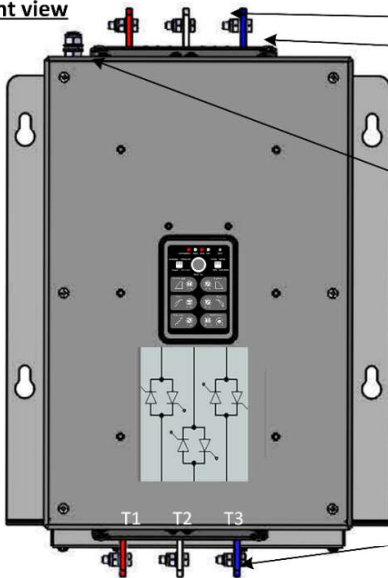

GRID input side

- Grid line terminals L1, L2, L3
- Grid bypass terminals BL1, BL2, BL3

Earth stud

MOTOR output side:

- Motor terminals T1, T2, T3
- (Also allows for Bypass Contactor)

View from the Bottom

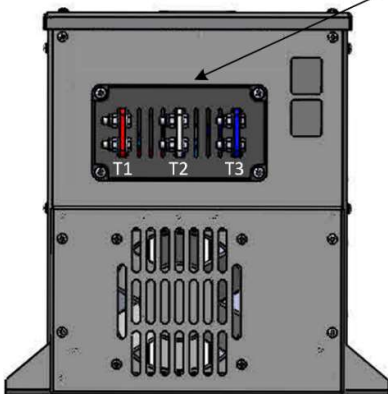

Figure 20 – Soft starter Core variant terminal identification

NOTES:

- To prevent a malfunction due to noise, route the signal cables 10 cm or more away from the power cables. Also, separate the main circuit cables at the input side from the main circuit cables at the output side.
- After wiring, wire offcuts must not be left in the cabinet. Always keep the soft starter cabinet clean. When drilling mounting holes in a cabinet etc., take caution not to allow shavings, chips and other foreign matter to enter the soft starter.

3.2 Wiring instructions

3.2.1 Power Terminals – Main circuit

Wiring of the Main circuit of the soft starter and the motor is specified in Table 10 and Table 11 and shown in Figure 21.

Table 10: Power terminals wiring

Terminal symbol	Terminal name	Terminal function description
L1,L2,L3	3 phase AC power input.	Connect these terminals via fuses and MCCB to the three-phase supply lines. (Refer Figure 7). ⚠ Ensure to connect the supply power to the correct terminals as shown in Figure 21 and Figure 19 or Figure 20
T1,T2,T3	Soft starter power output to motor and for models without built-in bypass contactor:	Connect these terminals straight to a three-phase squirrel cage motor. (No power factor correction capacitors should be fitted between the soft starter and the motor). Connect these terminals from the bypass contactor to the soft starter
BL1,BL2,BL3	3 phase AC power to bypass contactor.	Connect these terminals to the external bypass contactor. The bypass contactor should be controlled by the Soft starter Bypass Relay output.



Figure 21 – Power wiring on the soft starter

- ⚠ Note that if bypass terminals are not used, they should be covered for safety. The cable sizes and connection lugs for the Main circuit are specified in Table 11.

Table 11: Power wiring size and tightening torque specification

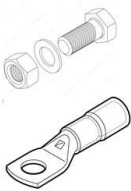
Inverter model	Lug, Nut and Bolt size	Tightening torque [Nm]	Cable size
MEsoftstart/I00		M6	Select the cable size according to the motor maximum starting current. Refer to local installation standards for the site.
MEsoftstart/I01		M6	
MEsoftstart/I02		M8	
MEsoftstart/I03		M12	
MEsoftstart/I04		M12	

3.2.2 Earthing stud

The earthing stud on the soft starter should be connected to the cabinet ground or other low-impedance earthing point using the guidelines shown in Figure 22. The voltage measuring channels of the soft starter require a system earthing to work correctly. A lack of proper earthing connection may cause the soft starter to behave erratically.

The Earthing wire should be as short as possible (preferably less than 0.5 m). The earthing stud is an M8 bolt on all MEsoftstart models. Use the same cable cross section as selected for power wiring in Table 11.

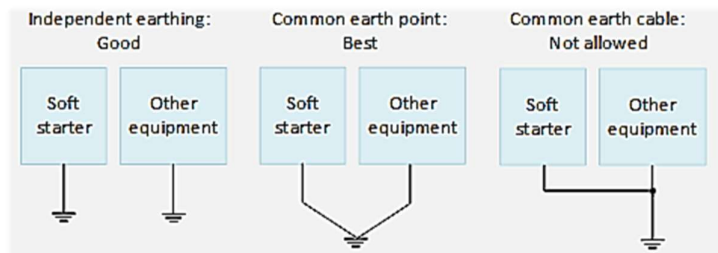

Figure 22 – Earthing wiring on the soft starter

3.2.3 Protective guards over the power terminals

After connecting all the AC cables, and before switching on the grid supply power, fit the protective guards supplied with the soft starter. Pull the side sections slightly apart to slide over the busbar terminal block until the two front lips and lip on each side clip in position under the terminal block.

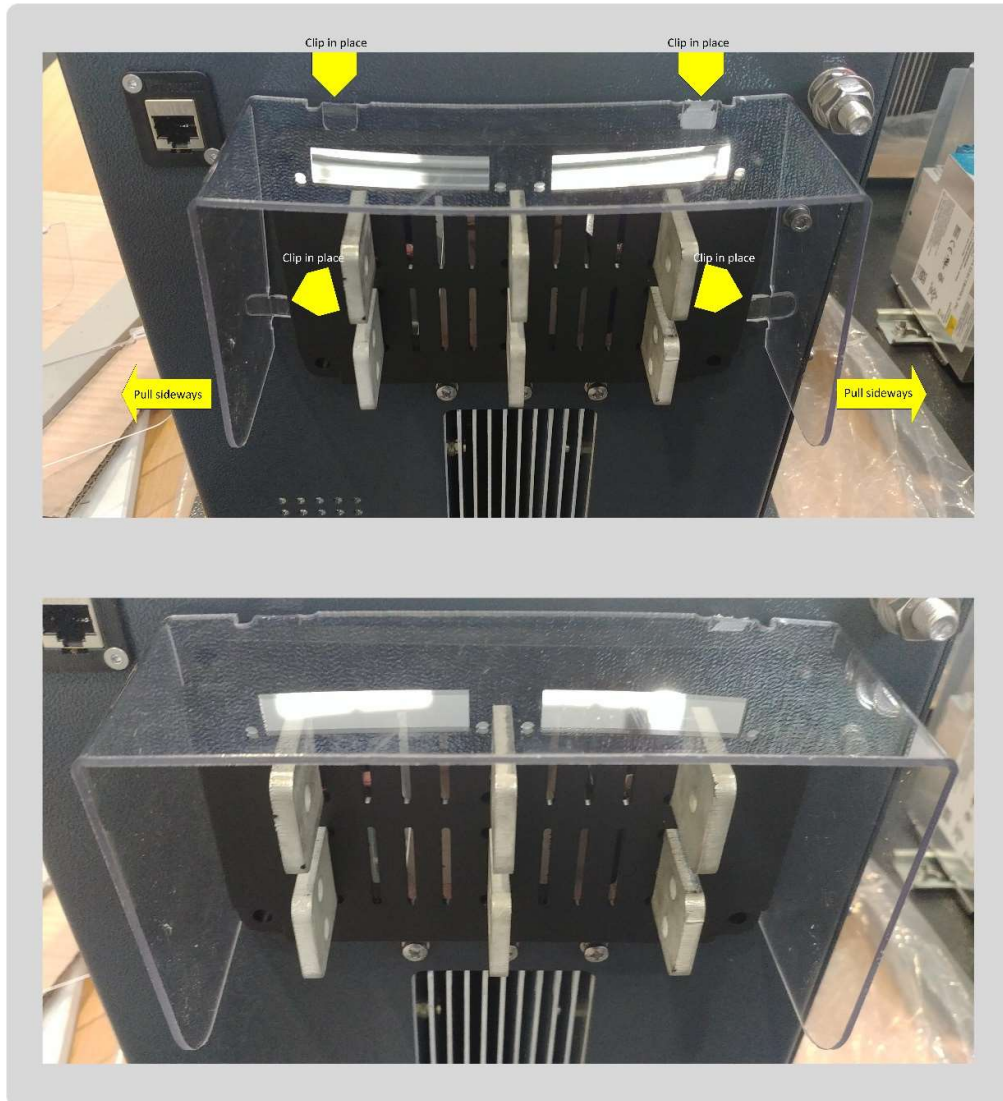

Figure 23 – Fitting protective guards over terminals

3.2.4 Wiring terminals on the Pro variants

This section defines the wiring terminals on the full-featured MEsoftstart/I pro range of soft starters.

3.2.4.1 Wiring terminal X1 (Pro) – Control outputs

The green wiring terminal X1 on the bottom side of the soft starter (refer Figure 19) provides access to the control outputs of the soft starter.

Table 12: Control output wiring terminals on the Pro models

Terminal	Terminal name	Terminal function description
X1-1	Ready-Relay	This output signal from the soft starter will be active when the soft starter is ready to start the motor. It may be used for a remote device to be able to start the motor. The signal will be inactive when configuring the soft starter and while the motor is starting, running, stopping or the delay between starts is implemented.
X1-2	Ready_Relay return	
X1-3	Run-Relay	This output signal from the soft starter will be active when the soft starter is busy starting, running or stopping the motor. It may be used to monitor the operation of the soft starter.
X1-4	Run_Relay return	
X1-5	Shunt Trip Relay	This output signal from the soft starter will be active whenever an internal stack over current is detected.
X1-6	Shunt Trip Relay return	
X1-7	Phase A	These input signals to the soft starter are used to be able to connect a shaft sensor to measure the motor's revolutions per minute. The MEsoftstart soft starter is not delivered with a shaft sensor. A compatible shaft sensor may be ordered with the soft starter.
X1-8	Phase B	
X1-9	Sensor-GND	
X1-10	Not Connected	-

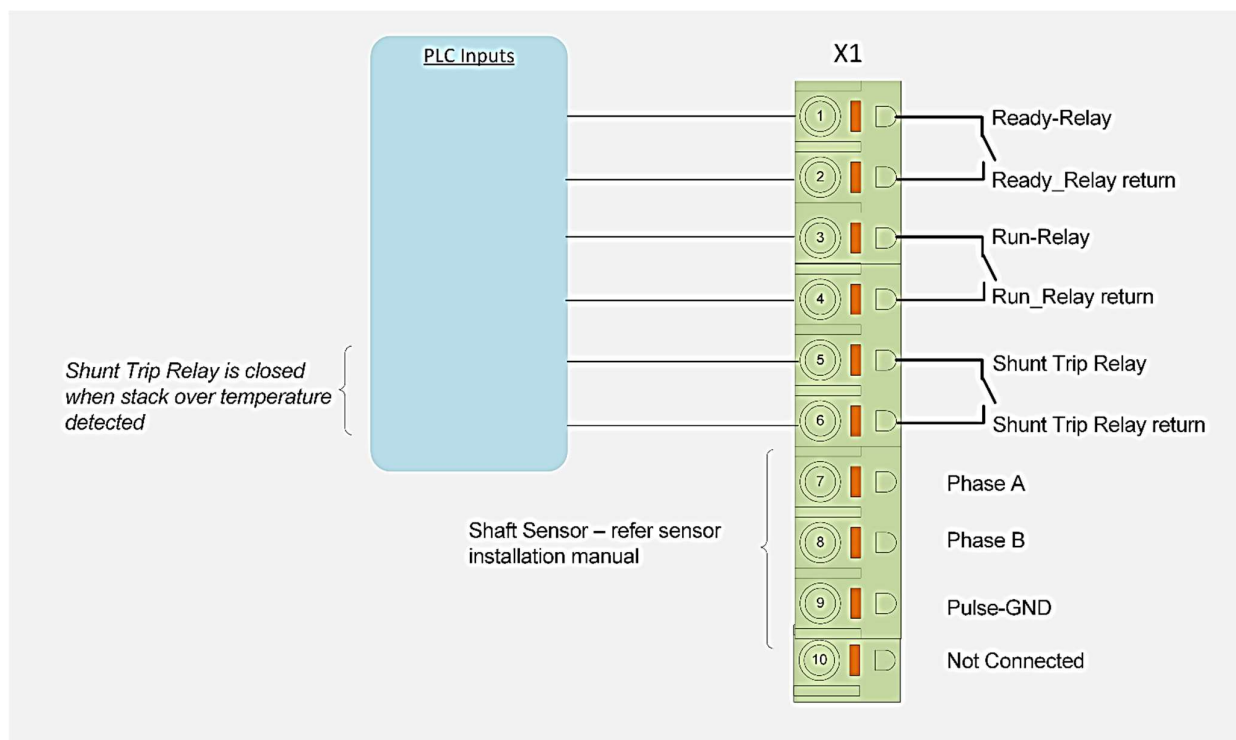

Figure 24 – Terminal X1 (Pro) – wiring example

3.2.4.2 Wiring terminal X2 (Pro) – Temperature Sensors and Contactor control

The green wiring terminal X2 on the bottom side of the soft starter (refer Figure 19) provides access to the terminals where the external temperature sensors should be connected and where the reversing or bypass contactors can be connected.

Table 13: Temperature sensor input and contactor output terminals on the Pro models

Terminal	Terminal name	Terminal function description
X2-1	PT-100 (A)	PT-100 3-wire temperature sensor. <i>Note:</i> MSoftstart soft starters are not delivered with a temperature sensor as standard. Please include the optional, compatible temperature sensor when ordering the soft starter.
X2-2	PT-100 (B)	
X2-3	PT-100 (B)	
X2-4	LM35 GND	These terminals provide access to 24V and ground for an LM35-type temperature sensor on the motor. The soft starter will read the sensor and be able to limit current to the motor when the temperature rises above the pre-configured maximum for the motor. Refer Figure 7. <i>Note:</i> MSoftstart soft starters are not delivered with a temperature sensor as standard. Please include the optional, compatible temperature sensor when ordering the soft starter.
X2-5	LM35 Signal	
X2-6	LM35 +24V	
X2-7	Reversing Contactor	<i>Note:</i> Future function – not available in MSoftstart firmware version 2.0 and earlier Terminals for a reversing contactor that is under the Soft starter control – used for braking a motor for fast stop. The firmware version no. can be found at the top of all TFT touchscreen displays (see Figure 39) and/or on a Modbus master such as the PC App (see Figure 58).
X2-8	Reversing Contactor Return	
X2-9	Bypass Contactor	Terminals for an external bypass contactor that is under the Soft starter control. (* Ensure to configure the soft starter for use with a bypass contactor.)
X2-10	Bypass Contactor Return	

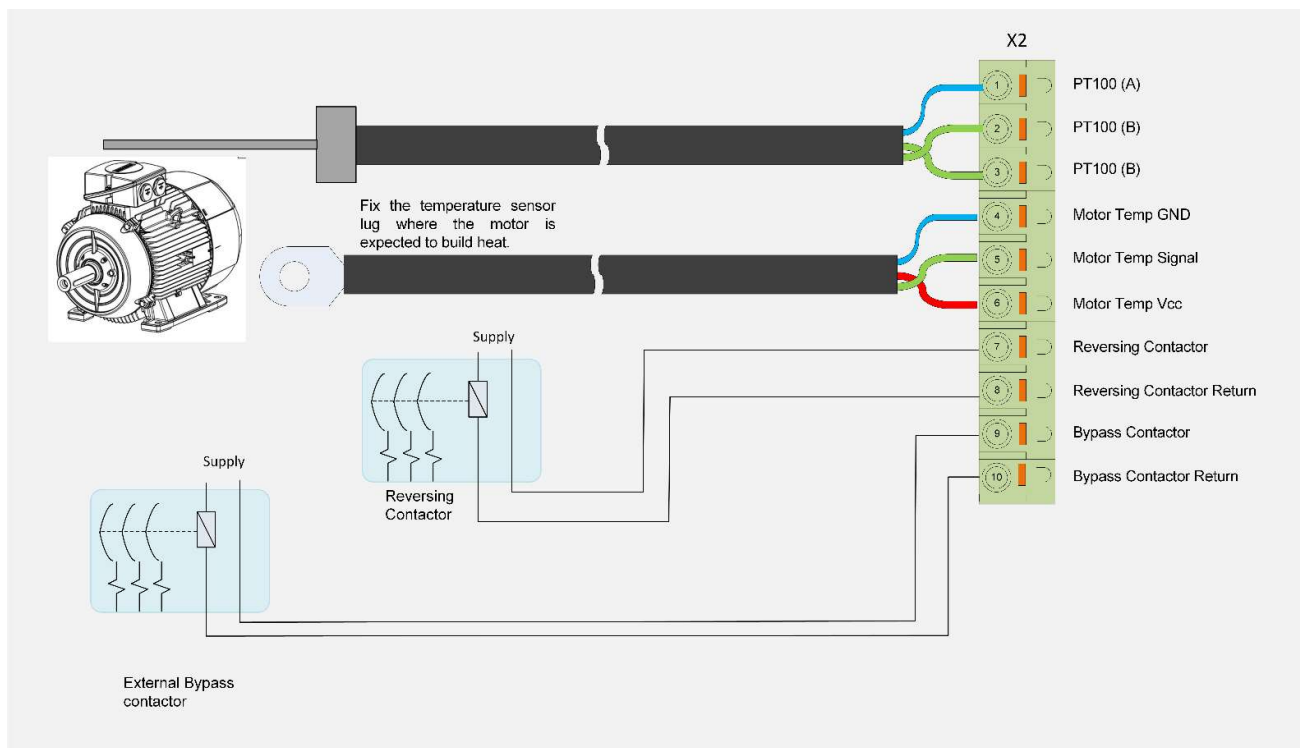

Figure 25 – Terminal X2 (Pro) – wiring example

3.2.4.3 Wiring terminal X3 (Pro) – Communications and Control inputs

The green wiring terminal X3 on the top side of the soft starter (refer Figure 19) provides access to the wiring terminals for the PC Interface and is where the Auto/Maintenance, remote start and reset signals to the soft starter, should be connected.

Table 14: Communication and Control I/O wiring terminals on the Pro models

Terminal	Terminal name	Terminal function description
X3-1	RS-485 A and -B	Communication port for control expansion. Two wire RS485-A and RS485-B terminals. Functionality to be defined.
X3-2		
X3-3		
X3-4	Over Alarm	Output: Motor overload alarm. This output is activated when the measured current is higher than the frame size or higher than the Motor Overload Current (MOLC) parameter in the configuration.
X3-5	Over Alarm Return	
X3-6	Fault / Incoming Alarm	Output: This is a configurable output and can be set to either be an indication of 3 phase power present in the soft starter OR a fault detected by the soft starter. The Fault output is reset when the user presses RESET on the TFT or via the PC interface or remote reset.
X3-7	Fault / Incoming Alarm Return	
X3-8	Auto / Maintenance	Input: Auto / Maintenance. When this signal is active the Soft starter is in 'Auto' and control will be possible from any remote location via RTU, TCP, PLC discrete inputs AND the TFT or Pot HMI on the box. When this signal is not active the Soft starter is in 'Maintenance' and the control will be possible from local location only i.e. via TFT or Pot HMI. ⚠ NOTE that this is a normally-closed switch connection. If not used the terminals must be bridged or the soft starter will be in Maintenance.
X3-9	Return	This is the return signal for Auto/Maintenance input AND Remote Start input.
X3-10	Remote Start	Input: When the soft starter is configured for 'REMOTE' control, this input will start the soft starter. This is an input signal to the soft starter and may be used to remotely start the motor from e.g. a PLC controller. The controller should use the Ready Relay output (refer Table 12 X1-1 and X1-2) to be able to detect when the soft starter is ready to start the motor. ⚠ NOTE that the system must be configured for REMOTE operation (refer paragraph 6.7.1). Close this contactor to start the motor, open it to Stop the motor.

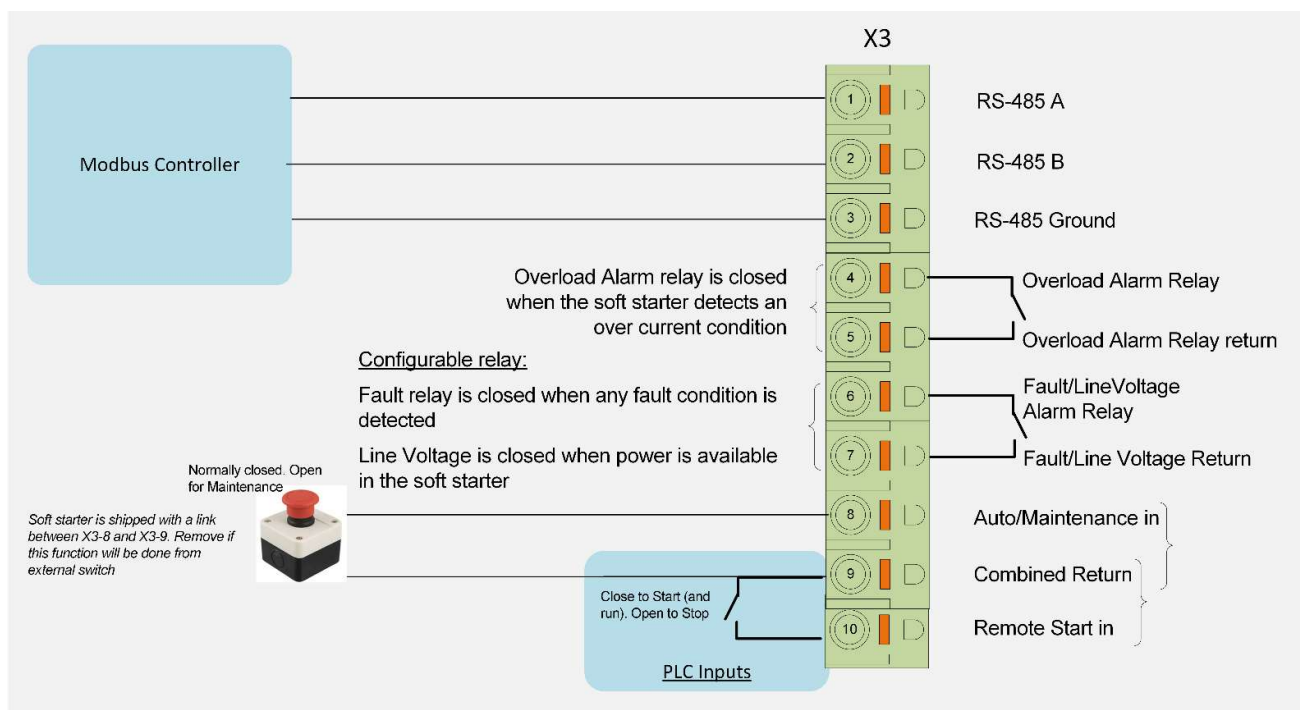

Figure 26 – Terminal X3 (Pro) – wiring example

3.2.4.4 Wiring terminal X4 (Pro) – Control I/O and power

The green wiring terminal X4 on the top side of the soft starter (refer Figure 19) provides access to the wiring terminals for the PC Interface and is where the Reset, Temperature fault monitoring and external 24V DC may optionally be connected.

Table 15: DC power and Control I/O wiring terminals on the Pro models

Terminal	Terminal name	Terminal function description
X4-1	External reset-in	This is an input signal to the soft starter and may be used to remotely reset the soft starter from e.g. a PLC controller.
X4-2	External reset-in return	⚠ NOTE that the system must be configured for REMOTE operation (refer paragraph 6.7.1). Close this contactor to reset the soft starter, open it to allow the soft starter to continue.
X4-3	Temperature Fault	Output: This output is set active when the soft starter trips due to a high temperature on internal heatsinks or on the motor.
X4-4	Temperature Fault return	
X4-5	Not Connected	-
X4-6	Not Connected	-
X4-7	Not Connected	-
X4-8	Not Connected	-
X4-9	24V DC	Provide 24V DC (1A) on this input to be able to safely configure the soft starter, or update software, without having the 3 phase power connected.
X4-10	DC Ground	

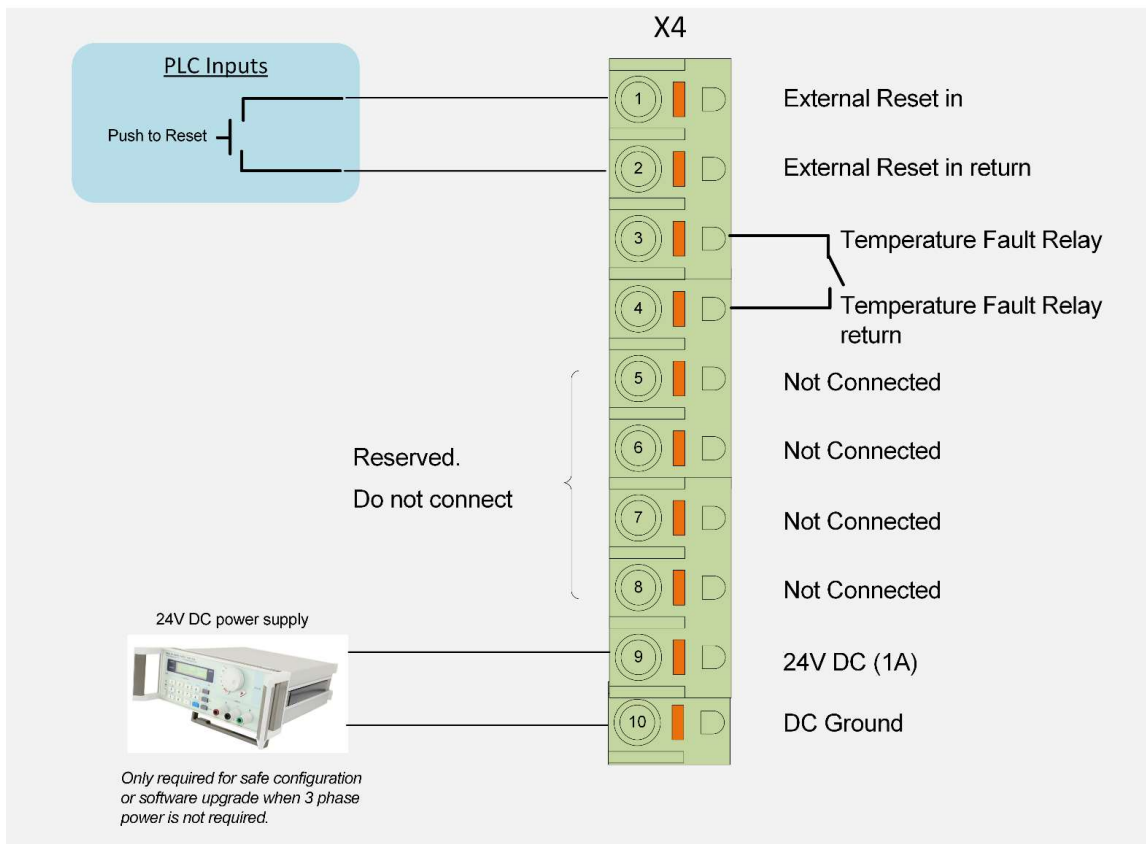

Figure 27 – Terminal X4 (Pro) – wiring example

3.2.5 Wiring terminals on the Core variants

This section defines the wiring terminal connectors for the MEdsoftstart/I Core variants of Industrial soft starters.

3.2.5.1 Wiring terminal X1 (Core) – Control outputs

The green wiring terminal X1 on the top side of the soft starter (refer Figure 20) provides access to the control outputs of the soft starter and is where the external temperature sensors should be connected.

Table 16: Control output and temperature sensor wiring terminals on the Core models

Terminal	Terminal name	Terminal function description
X1-1	Ready-Relay	This output signal from the soft starter will be active when the soft starter is ready to start the motor. It may be used for a remote device to be able to start the motor. The signal will be inactive when configuring the soft starter and while the motor is starting, running, stopping or the delay between starts is implemented.
X1-2	Ready_Relay return	
X1-3	Run/Bypass Relay	This output signal from the soft starter will be active when the start-ramp is completed and the motor is running. It may be used to switch power to the motor using a bypass contactor once the motor is running and to again open the bypass contactor when the soft starter is stopping the motor. Refer Figure 7
X1-4	Run/Bypass_Relay	
X1-5	Fault Relay	This output signal from the soft starter will be active whenever an internal stack over current is detected.
X1-6	Fault Relay return	
X1-7	Not connected	
X1-8	PT-100 (A)	-PT-100 3-wire temperature sensor. <i>Note:</i> MEdsoftstart soft starters are not delivered with a temperature sensor as standard. Please include the optional, compatible temperature sensor when ordering the soft starter.
X1-9	PT-100 (B)	
X1-10	PT-100 (B)	

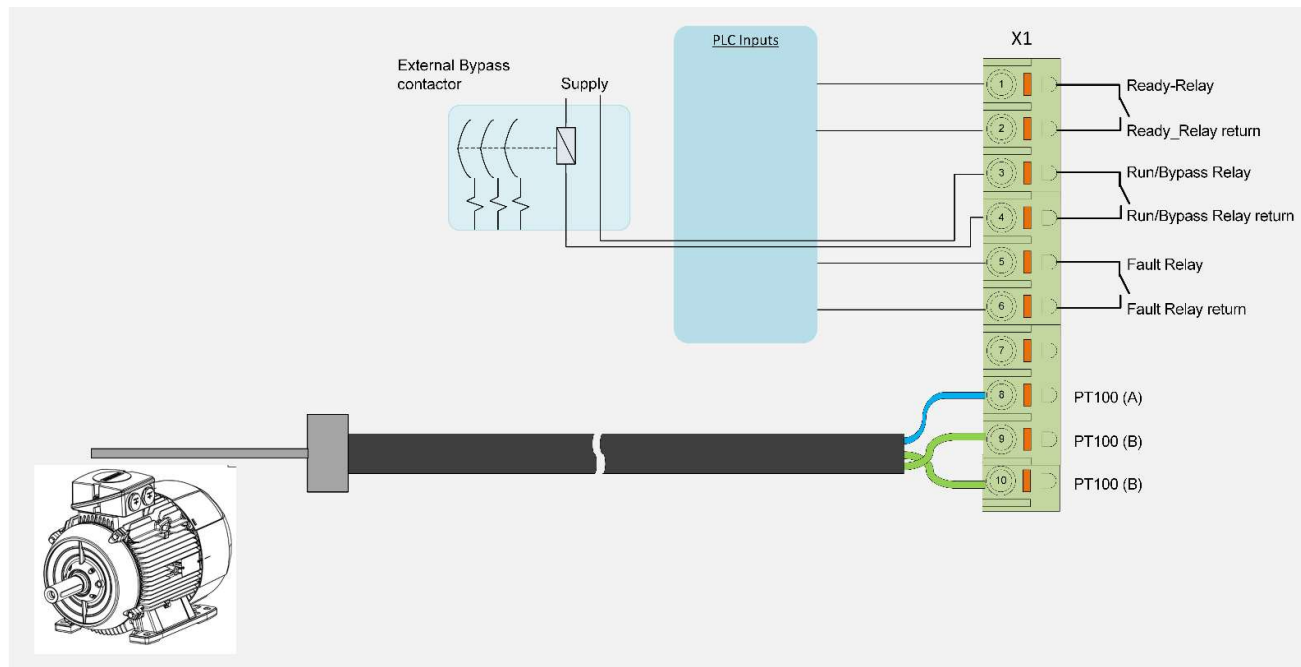

Figure 28 – Terminal X1 (Core) – wiring example

3.2.5.2 Wiring terminal X2 (Core) – Control I/O and power

The green wiring terminal X2 on the top side of the soft starter (refer Figure 20) provides access to the wiring terminals for the PC Interface and is where the Auto/Maintenance, remote start and reset signals to the soft starter, should be connected.

Table 17: Communication and Control I/O wiring terminals on the Core models

Terminal	Terminal name	Terminal function description
X2-1	External reset-in	<p>This is an input signal to the soft starter and may be used to remotely reset the soft starter from e.g. a PLC controller.</p> <p>NOTE that the system must be configured for REMOTE operation (refer paragraph 6.7.1), close this contactor to reset the soft starter, open it to allow the soft starter to continue.</p>
X2-2	External reset-in return	
X2-3	Remote Start/Stop	<p>Input: This input will start the soft starter when the switch is closed and stop the soft starter when the switch is opened.</p> <p>This is an input signal to the soft starter and may be used to remotely start the motor from e.g. a PLC controller. The controller should use the Ready Relay output (refer Table 12 X1-1 and X1-2) to be able to detect when the soft starter is ready to start the motor.</p>
X2-4	Remote Start/Stop Return and Auto / Maintenance Return	<p>NOTE that the if the system is started with this signal and then stopped from the HMI push-button or Modbus controller, this switch will first have to be opened and then again closed before the motor will again start from a remote signal</p>
X2-5	Auto / Maintenance	<p>Input: Auto / Maintenance. When this signal is active the Soft starter is in 'Auto' and control will be possible from any remote location via RTU, TCP, PLC discrete inputs AND the TFT or Pot HMI on the box. When this signal is not active the Soft starter is in 'Maintenance' and the control will be possible from local location only i.e. via the Potentiometer HMI.</p> <p>NOTE that this is a normally-closed switch connection. If not used the terminals must be bridged or the soft starter will be in Maintenance.</p>
X2-6	RS-485 A and -B	<p>Modbus RTU communication port. Two wire RS485-A and RS485-B terminals.</p> <p>(This port is also available on J2 and J3 RJ45 connectors)</p>
X2-7		
X2-8	RS-485 Ground	
X2-9	DC Ground	<p>Provide 24V DC (1A) on this input to be able to safely configure the soft starter, or update software, without having the 3 phase power connected.</p>
X2-10	24V DC	

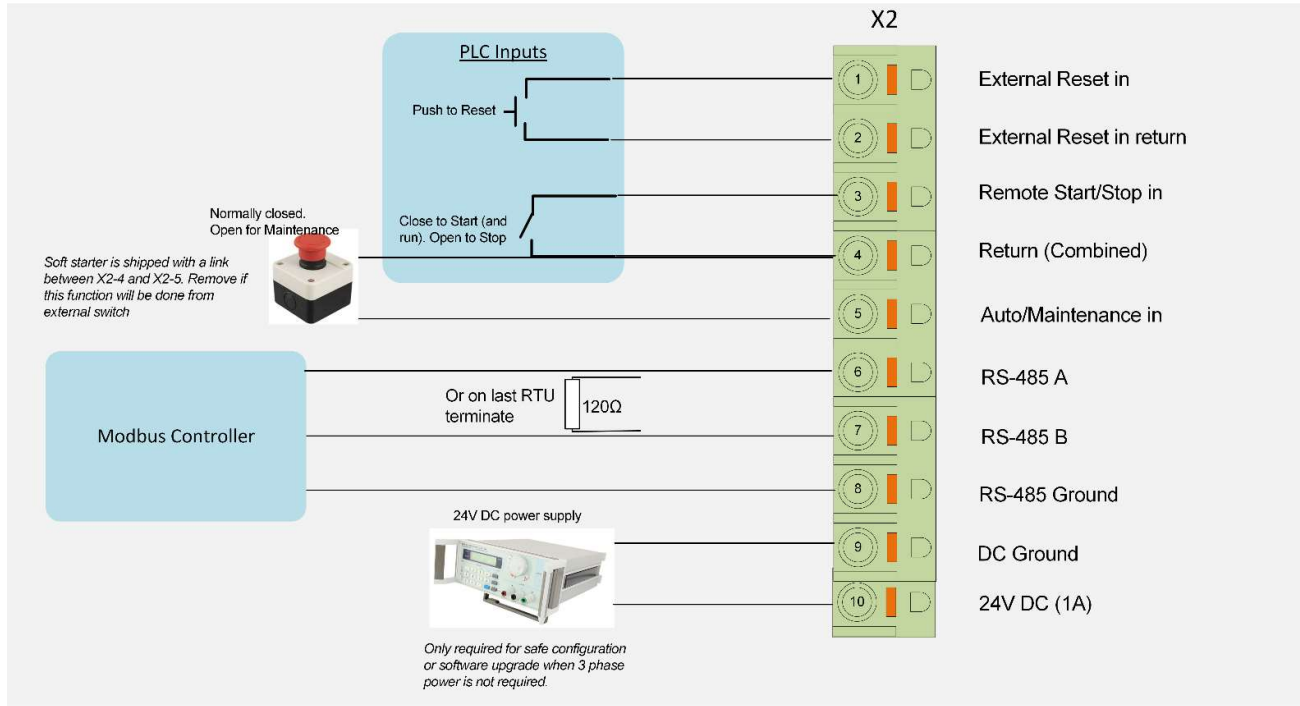

Figure 29 – Terminal X2 (Core) – wiring example

3.2.6 MSoftstart PC Interface

The MSoftstart PC interface is available as a two-wire RS485 port plus ground Modbus RTU interface on all MSoftstart/I models (MSoftstart/I00 – MSoftstart/I04).

On Pro variants of MSoftstart/I01 – MSoftstart/I04, the MSoftstart PC interface is also available on the Modbus TCP interface (on the Ethernet port).

For the Modbus RTU it is recommended to use the dedicated RS485 to USB cable that is available with the MSoftstart PC App. This cable plugs in on the J2 or J3 RJ45 connectors on the soft starter (refer Figure 19) and connects to a USB port on the PC.

Note that drivers for the RS485 to USB converter may need to be installed. For the MSoftstart dedicated cable, the drivers will be provided with the cable. Refer par 7.1 for instructions to install the drivers and the application.

The soft starters may be daisy-chained on the RS485 line to enable the PC to configure them one after the other without having to move the cable. To minimise reflections the RS485 lines need to be terminated with a 120Ω resistor at the far end.

Modbus TCP is available on the Pro variants' Ethernet RJ45 port on J1 and a standard Ethernet cable may be used between the soft starter and the PC, SCADA or PLC as required.

4. PRECAUTIONS FOR USE OF THE SOFT STARTER

 This chapter explains the precautions for use of this product. Always read the instructions before using the equipment.

4.	PRECAUTIONS FOR USE OF THE SOFT STARTER	45
4.1	CHECKLIST BEFORE APPLYING POWER.....	46

4.1 Checklist before applying power

The MEssoftstart/I series soft starter is a highly reliable product, but an incorrect peripheral circuit may shorten the product life or damage the product. Before starting operation, always recheck the following points:

Checkpoint	Countermeasure	Refer	Checked
The soft starter model is appropriate for the motor that will be connected to it.	<p>If the soft starter model is not appropriate for the motor that it is connected to, the starting current may not be enough and the motor can overheat.</p> <ul style="list-style-type: none"> - Consider a larger model soft starter. - Consider connecting the soft starter inside delta to the motor. - Consider adding an external bypass contactor (for models without built in contactor) - this may reduce the thermal load on the soft starter. - Contact your local distributor for assistance to find the best solution. 	<p>Table 1 Table 2 Table 3</p> <p>Model: MEssoftstart/I03</p> <p>Continuous rated current: Max. starting current: Max starting current:</p> <p>600A 1440A 750A</p> <p>Normal duty Heavy Duty</p> <p>Table 4 Table 4 Table 5</p>	
There is adequate space for air-flow around the soft starter.	If the air-flow is restricted, the soft starter will overheat and trip.	Paragraph 2.3.3	
Terminals are insulated.	Use terminals with insulation sleeves to wire the power supply and the motor.	Figure 21	
The main circuit cable gauge is adequate.	Use an appropriate cable gauge to suppress the voltage drop to 2% or less. If the wiring distance is long between the soft starter and motor, the voltage drop in the main circuit will cause the motor torque to decrease.	Local standards	
The wiring is correct:	<p>Direct application of power to the motor-side output terminals (T1, T2, T3) of the soft starter will damage the soft starter. Inadvertently connecting the supply lines to the Bypass terminals will damage the soft starter</p> <ul style="list-style-type: none"> - Confirm that the line voltage is within the soft starter's rated voltage range. - Confirm that the circuit breaker selected is adequate for the motor maximum starting current. - Confirm that the fuses that are installed are according to the specification in Table 7 for the selected soft starter model. - Confirm that if an external bypass contactor is used, the contactor is rated for the operating current of the motor. 	Table 7	
Wiring between the supply lines (L1, L2, L3), Circuit breaker, Fuses, soft starter and motor is correct.			
If an external bypass contactor is used, the wiring between the bypass terminals is correct.			

Checkpoint	Countermeasure	Refer	Checked
	<ul style="list-style-type: none"> - If the phases to or from the bypass contactor are swapped around, a short circuit will be caused between phases when the soft starter closes the bypass. - Before switch-on, inspect to confirm that the phases on the bypass contactor are wired using the same orientation as on the soft starter. 		
No wire offcuts or remnants from drilling are left in the enclosure.	Wire offcuts can cause failure or malfunction. Always keep the soft starter and enclosure clean. When drilling mounting holes in a cabinet etc., take caution not to allow chips and other foreign matter to enter the soft starter or to remain in the enclosure.	Paragraph 2.3.6	
The protective covers are in place over the Grid and Motor terminals.	The protective covers should be replaced once the wiring is done and before applying power to the soft starter.	Par 3.2.3	
Emergency stop is wired to the circuit breaker and is in a position where the operator has easy access.	The emergency stop should remove all power to the soft starter and the motor and should be hard wired to the main circuit breaker to ensure that the operator can reliably stop the motor in case of an emergency.	Figure 7	
Countermeasures are taken against EMI.	The input/output (main circuit) of the soft starter includes high frequency components, which may interfere with the communication devices (such as AM radios) used near the soft starter. In such case, install a noise filter.	-	
On the soft starter's output side, there should be no power factor correction capacitor, surge suppressor, or radio noise filter installed.	Such installation will cause the soft starter to trip or the capacitor and surge suppressor to be damaged. If any of the above devices are connected, remove it before power is applied.	Paragraph 2.1.4	
No short circuit or ground fault is present on the soft starter's output side.	<ul style="list-style-type: none"> - A short circuit or ground fault on the soft starter's output side may damage the soft starter. - Fully check the insulation resistance of the circuit prior to installing the soft starter. Repeated short circuits caused by peripheral circuits inadequacy or a ground fault caused by wiring insulation inadequacy or reduced motor insulation resistance may damage the soft starter module. - Fully check the phase-to-earthing (ground) insulation and phase-to-phase 	-	

Checkpoint	Countermeasure	Refer	Checked
	<p>insulation of the soft starter's output side before connecting the soft starter.</p> <ul style="list-style-type: none"> - This is especially important for an installation with an existing or old motor or use in a hostile atmosphere to make sure to check the motor insulation resistance. 		
<p>The voltage applied to the soft starter I/O signal circuits is within the specifications.</p>	<p>Application of a voltage higher than the permissible voltage to the soft starter I/O signal circuits or opposite polarity may damage the I/O devices.</p>	<p>Paragraph 3.2</p>	

5. BASIC OPERATION – CORE MODELS

This chapter explains the configuration and the basic operation of the core variants of MSoftstart Industrial soft starter.

⚠ This chapter explains the operation and use of this product. Always read the instructions before using the equipment.

5.	BASIC OPERATION – CORE MODELS	49
5.1	POWER-UP THE SOFT STARTER	50
5.2	CONFIGURE THE SOFT STARTER FOR THE APPLICATION	51
5.3	CONTROLLING THE SOFT STARTER	53
5.4	TROUBLESHOOTING THE MESHFTSTART/I CORE VARIANT	56



5.1 Power-up the soft starter

On power-up, the soft starter will be in IDLE mode. The user will be presented with HMI LEDs that indicates that the power is present and the supply phase is detected.

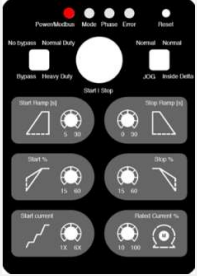
Power LED			
	When 24V power is present this LED will flash at a frequency of 0.5 Hz. When Modbus RTU communication has been established and the soft starter is under Modbus control this LED will flash at 1 Hz.		
	LED state	CPU state	Description
	LED off	No power	No power on the CPU card in the soft starter.
	0.5Hz Flashing	Power present; Modbus not detected	The power is present on the CPU card. CPU is not detecting any Modbus communication.
1 Hz Flashing	Power present; Modbus in control	The power is present on the CPU card. Soft starter is under Modbus control. Use the Modbus commands to start and stop the motor.	

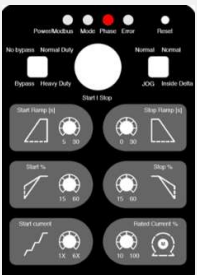
Phase LED			
	This LED indicates the detected phase of the applied 3-phase power. The configured phase orientation must be Clockwise. The interpretation of the Phase LED state is described in the table below.		
	LED state	Detected phase	Description
	LED off	Unknown phase	This occurs before AC power is applied and during phase synchronisation immediately after application of AC power.
	LED on	Correct phase	The phase rotation is correct.
0.5 Hz flashing	Phase error	An incorrect phase rotation is detected.	

If the Phase LED is flashing the indication is that the phase rotation of the 3-phase grid connection to the soft starter is incorrect. Switch off the grid voltage and swap the incoming phases.

The Mode LED should be off at this stage, indicating that the soft starter is in IDLE mode. The operational modes of the MSoftstart/I core model is illustrated in the Figure 30 below:

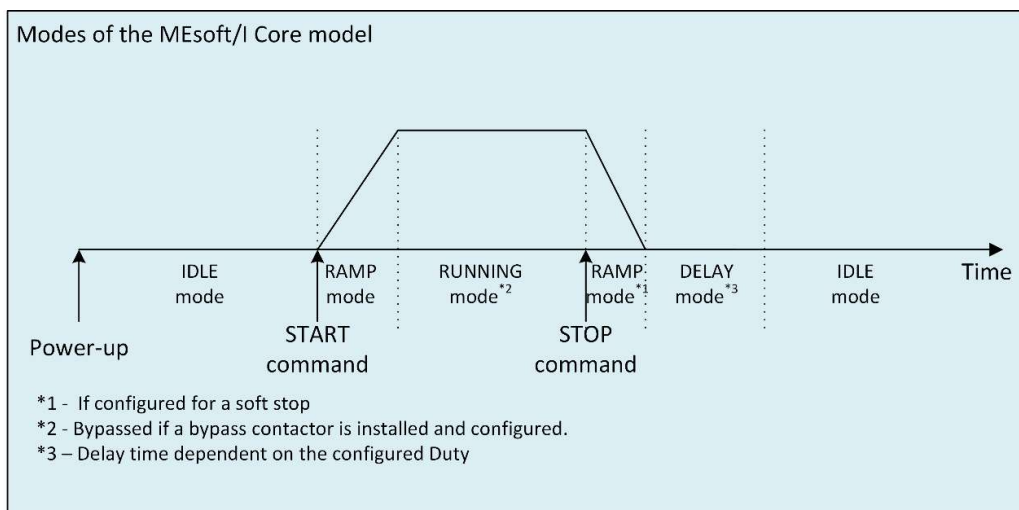

Figure 30 – MSoftstart/I Core operational modes

The Mode LED will indicate the operational mode of the soft starter as shown in the table below.

Mode LED		
LED state	Software mode	Mode description
LED off	Idle mode	This is the state when 24Vdc is present, but prior to application of the AC voltage, or if AC voltage is present but the soft starter is under Modbus control: prior to a START command.
5 Hz Flashing	Ramp mode	After a START or STOP command (HMI panel button, Modbus command or Remote command), while the ramp-up or ramp-down is in progress, the LED flashes.
LED on	Running mode	Ramp-up has been completed and if present, bypass contactor has been engaged. The motor should be running.
1 Hz flashing	Delay mode	After stop or ramp-down is completed, the Soft starter is implementing the restart delay time.
0.5 Hz flashing	Error mode	An error condition was detected. All switching elements are off. The soft starter awaits further operator intervention. See error LED for more details.

In the case that the soft starter is in ERROR mode, the Error LED will help to troubleshoot the cause of the fault – refer paragraph 5.4.

5.2 Configure the soft starter for the application

The MEsoftstart/I core models are easy to configure, using the guidelines listed below. The configuration options from the HMI panel are shown in Figure 31.

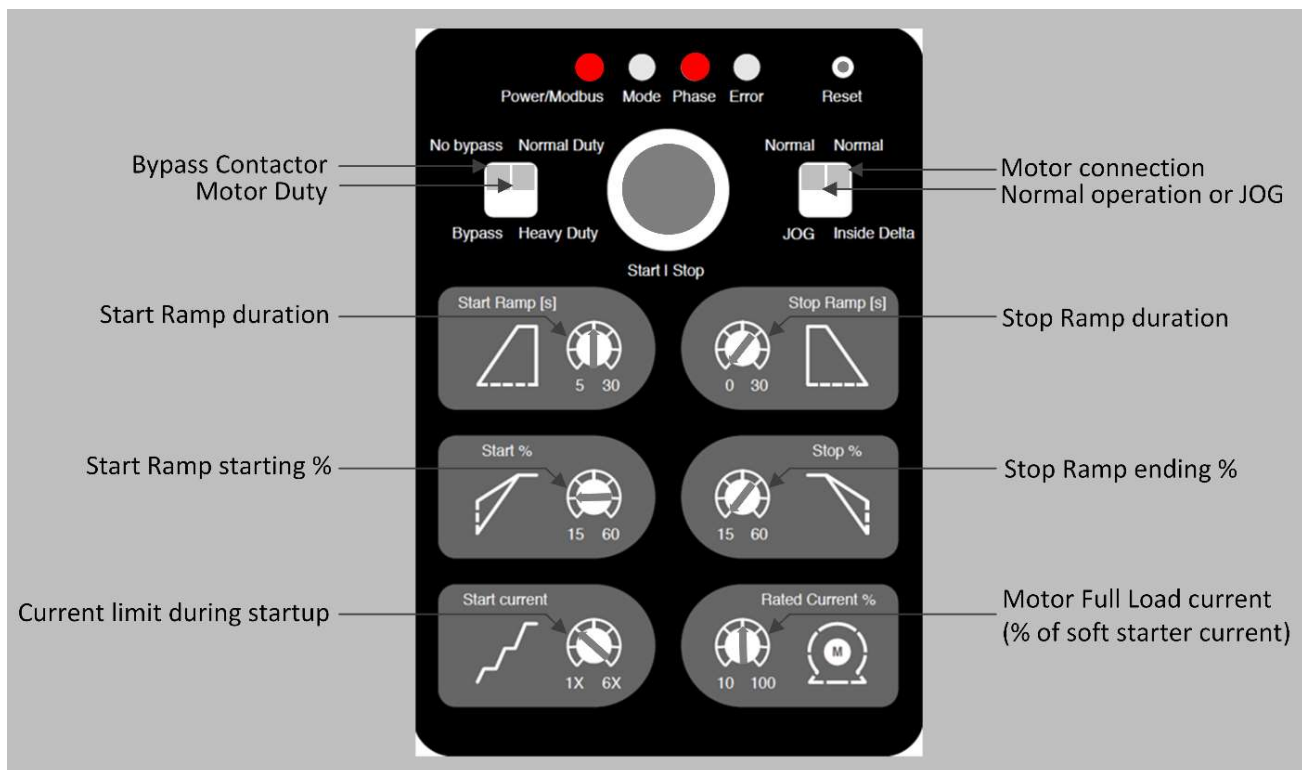

Figure 31 – MEsoftstart/I Core HMI configuration options

The switches to the left and right of the START | STOP key can be used to configure the soft starter as listed below:

51 Basic operation – Core models

Switch	Usage
Bypass	<p>The soft starter can be used with a built-in or external bypass contactor. A bypass contactor is activated once the motor is running and reduces the current through the soft starter switching elements while the motor is running. If present, the bypass contactor is controlled from the soft starter and is activated as soon as the motor is running and de-activated before the stop ramp commences.</p> <p>If the soft starter is configured for use without a bypass contactor, the running current of the motor passes through the soft starter for the entire time that the motor is running.</p> <p>A bypass contactor is recommended for installations where the motor is started a few times a day and run for long periods between starts.</p> <p>A bypass contactor does not add much value when the motor is started and then run for short intervals.</p> <p>For models with built-in contactors this switch should always be in the 'Bypass' position.</p>
Duty	<p>When the soft starter is installed in a site where the motor requires a long start ramp or more than 10 starts per hour, this switch should be set to Heavy Duty and the selection criteria in Table 1 to Table 2 for Heavy Duty should be used to scale the motor size and the soft starter. Heavy duty usage generates more heat internally to the soft starter and the lifespan of the soft starter will be affected if the soft starter is used in an application that is not suitable for the duty of the motor.</p> <p>The switch may be set to Normal Duty when the start ramp time is 30 seconds or less and the starts per hour is 10 or less.</p> <p>Note that when the switch is changed to 'Normal' the 'Maximum Number of starts per hour' reverts to 10. This may be changed using the Modbus interface (or PC Application) to any number of starts per hour up to 10.</p> <p>When the switch is changed to 'Heavy' the 'Maximum Number of starts per hour' reverts to 60. This may be changed using the Modbus interface (or PC Application) to any number of starts per hour up to 60.</p>
JOG	<p>The soft starter provides the capability to JOG the motor. This functionality may be used to e.g. align a conveyer belt with a loading bay. The JOG functionality will allow the user to slowly turn the motor <u>while the START button is being pressed</u>. The motor will coast to a stop when the START button is released.</p> <p>JOG will run the motor at the percentage as set by the Start Ramp Starting % potentiometer.</p> <p>The Motor Full Load Current % should be set correctly for the motor that is being used.</p> <p>The intention of JOG is to use the functionality for short, infrequent periods. Over-use of the JOG function will overheat the motor and the soft starter and will activate a temperature trip.</p> <p>The normal setting for this switch is 'NORMAL'. In NORMAL the START button will initiate a start ramp to start and run the motor.</p>
Motor connection	<p>The soft starter allows for motor to be wired in normal 3-wire connection or in 6-wire inside-delta connection. The inside-delta wiring allows for a lower current that flows through the soft starter and larger motors may be used with the same size soft starter. Refer to Figure 5 for Inside-Delta connection.</p> <p>Refer paragraph 2.1.1 and paragraph 2.1.2 to understand the difference between the wiring, to be able to make the correct selection.</p>

The potentiometers can be used to configure the soft starter as listed below:

Potentiometer	Usage
Start Ramp Duration	The duration of the start ramp can be adjusted from 5 seconds to 30 seconds.
Stop Ramp Duration	The stop ramp may be disabled by setting this dial to zero and the motor will coast to a stop. When a controlled soft-stop is required, the stop ramp duration may be set up to 30 seconds.
Start Ramp starting %	The Start Ramp may be started between 15% and 60% depending on the load of the motor. Starting the ramp at too low a percentage will cause heating build-up in the motor without actually turning the motor.

Stop Ramp ending %	If enabled, the stop ramp may be stopped at between 60% and 15% after which the motor will coast to a stop if not stopped already.
Current Limit during start-up	This potentiometer sets the current limit during start-up. The current can be limited between 1x and 6x (600%) the full load current of the motor (within the limits of the soft starter). Refer Table 1 to Table 2. <u>Example:</u> For the MEssoftstart/I00 which is a 100A soft starter with starting current of 240A in Normal Duty, the starting current for a 22kW motor with full load current of 40A at power factor of 0.8, may be limited to a value between 240A (6x or 600%) and e.g. 80A (2x or 200%) Note that if the potentiometer is set to a value higher than the soft starter starting current rating for the selected Duty and selected motor size, the current will be limited to the maximum that the soft starter can provide (as specified in Table 1 for the MEssoftstart/I00 and Table 2 for the MEssoftstart/I01).
Motor Full Load current	This potentiometer configures the size of the motor. The motor size is configured in relation to the soft starter continuous current. <u>Examples:</u> For the MEssoftstart/I00 which is a 100A continuous current soft starter: <ul style="list-style-type: none"> • Configure a 22kW motor (with 40A full load current at power factor of 0.8) at 40%. • Configure a 55kW motor (with 99A full load current at power factor of 0.8) at 100% For the MEssoftstart/I01 which is a 200A continuous current soft starter: <ul style="list-style-type: none"> • Configure a 75kW motor (with 135A full load current at power factor of 0.8) at 67%. • Configure a 110kW motor (with 199A full load current at power factor of 0.8) at 100%

5.2.1 Additional configuration parameters

In addition to these parameters, the soft starter may be configured via the Modbus RTU interface for:

- Motor protection class between 5 and 30 (default is 10).
- PT-100 motor temperature sensor to cause a trip on motor temperature more than the maximum allowed temperature.
- Maximum motor temperature (applicable if the PT-100 is selected) ([90°C - 175°C] - default is 120°C)
- Motor restart temperature (applicable if the PT-100 is selected) ([40°C - 90°C] - default is 60°C)
- Number of starts per hour [1 – 10] for Normal Duty (default is 10); unlimited for Heavy duty (default is 60)
- Voltage imbalance [0 – 25%]; default is 20%.
- Current imbalance [0 – 20%]; default is 10%.

5.3 Controlling the soft starter

The MEssoftstart/I Core models are easy to control, from the HMI panel, or from a remote controller via the inputs on the green I/O terminals, or from a Modbus controller via the Modbus RTU ports on the bottom of the soft starter.

5.3.1 Using the Auto/Maintenance-feature

The MEssoftstart soft starter features an Auto/Maintenance input on the green terminals, which may be used to prevent inadvertent START / STOP or RESET control of the soft starter from a remote location while e.g. maintenance is in progress.

Note that to be able to use the Auto/Maintenance function, the Maintenance switch must be wired on the soft starter (refer Table 17). Note that the Auto/Maintenance input on the soft starter must be normally closed (for the soft starter to be in Auto control to enable control from remote PLC, or any Modbus master, or the TFT panel). The Maintenance switch must open the

Auto/Maintenance input on the soft starter to prevent remote control of the soft starter. When the Auto/Maintenance input is open, the soft starter will only accept control inputs locally on the soft starter, from the TFT panel.

- ⚠ The Auto/Maintenance feature must never be used in place of a proper safety procedure to ensure the safety of personnel working on the soft starter or the motor.

5.3.2 Start, Stop or Reset

The user may START, STOP or RESET the motor via the MSoftstart/I soft starter as shown in Figure 34.

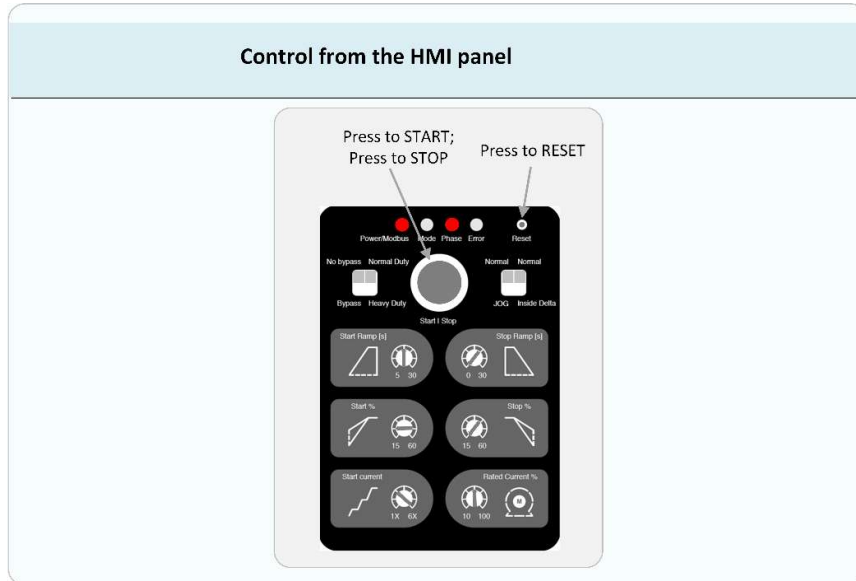

Figure 32 – MSoftstart/I Core – Start, Stop and Reset control options from the HMI panel

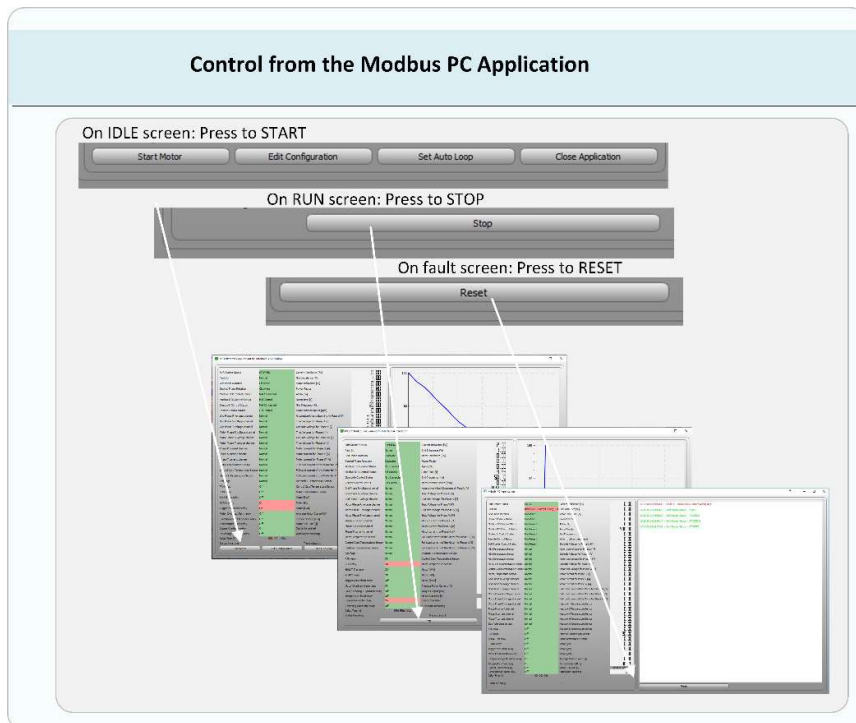

Figure 33 – MSoftstart/I Core – Start, Stop and Reset control options from the PC Application

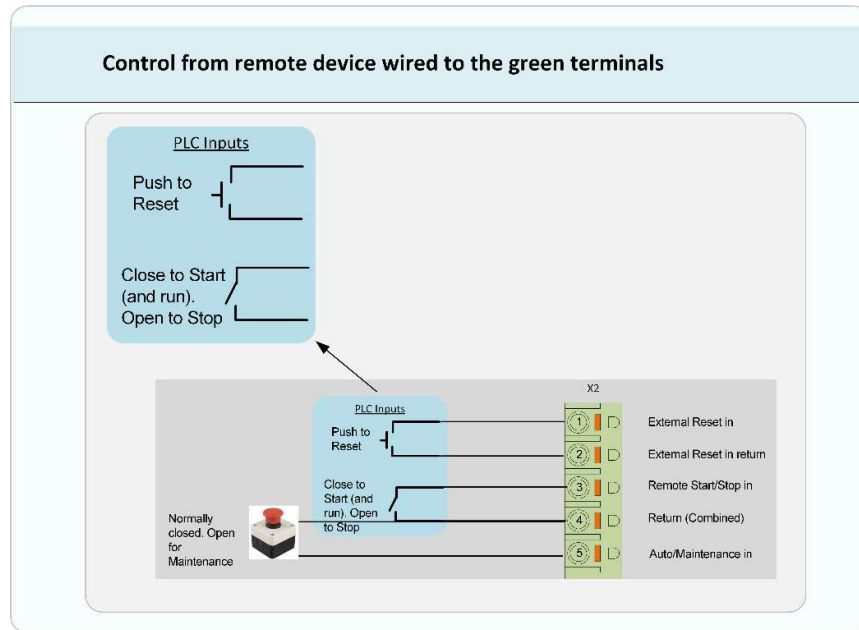

Figure 34 – Msoftstart/I Core – Start, Stop and Reset control options from the green wiring terminals

Note that (when in Auto control) the motor can be started from any of the three control inputs and stopped from any of the three control inputs.

Example: If the motor is started from a remote controller by closing the switch on the green terminal and then the motor is stopped by pushing the START/STOP button on the HMI panel, the motor will be stopped and can only be started again from the remote controller after the switch is opened and then closed again.

- ⚠ If work needs to be done on the motor or the load, ensure that the Main supply is switched off to prevent inadvertent starting from a remote switch or Modbus Master.

If an error occurs the motor will be stopped and the ERROR LED will be flashing to indicate the cause of the fault - refer paragraph 5.4. Once the cause of the fault is understood and removed, the soft starter will have to be RESET before operation can continue. RESET can be done from the HMI panel, the Modbus RTU controller or a remote controller on the green terminal.

5.3.3 Jog

The 'Jog' functionality is available to slowly crawl a motor and its load to e.g. align a conveyor with a loading bay. Jog can be configured and controlled from the HMI panel, as shown in Figure 35.

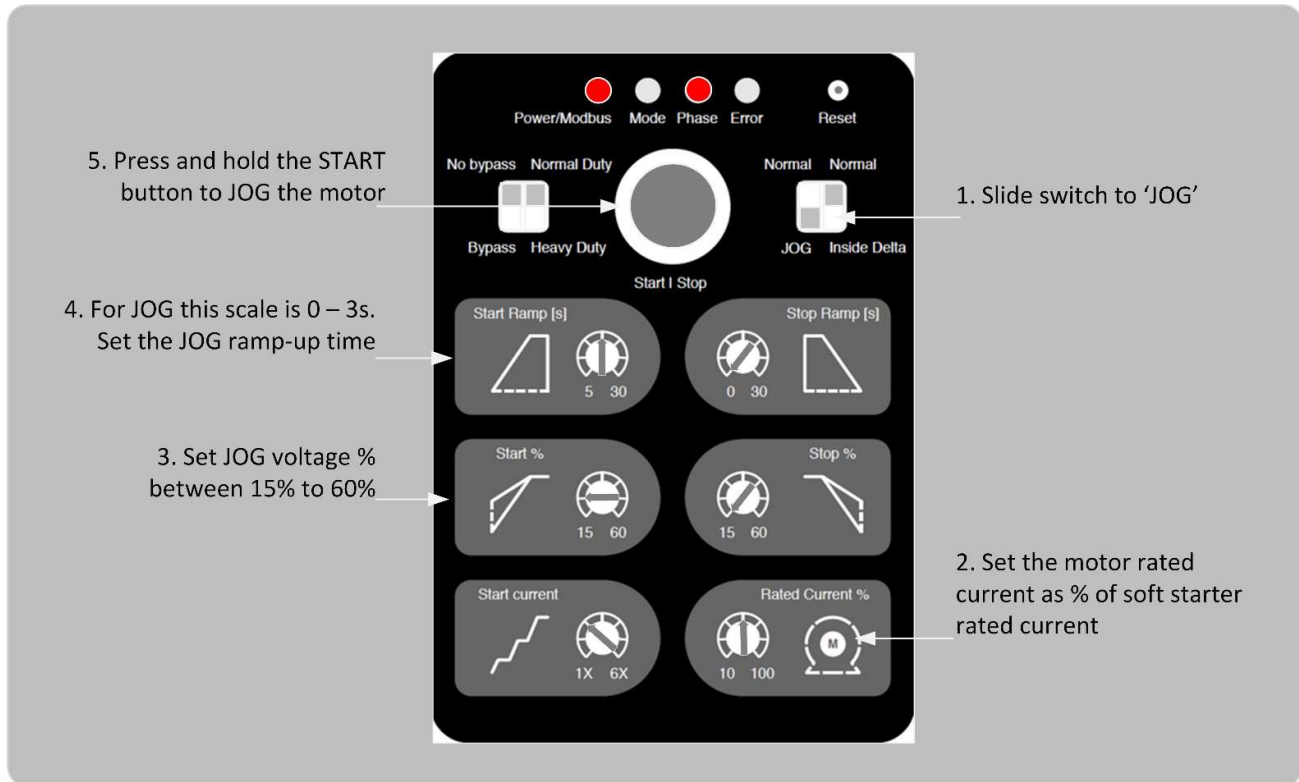

Figure 35 – MEsoftstart/I Core – JOG setup and control

- ⚠ Take care not to over-use the JOG functionality as the motor and the internal switching elements in the soft starter will overheat quickly if JOG is done for prolonged periods.

5.4 Troubleshooting the MEsoftstart/I core variant

5.4.1 No LEDs on

When connected to three phase power the Power LED should be on, and the Phase LED should be either ON or flashing. If neither of these two LEDs are on the following checks should be done:

- i. Measure the incoming three phase supply power on the Grid-side terminals of the soft starter. If there is not supply power on all three terminals, check the Main Circuit Breaker and contact the installer to find the problem.
- ii. If the supply voltage is present on all three phases (measured on all three terminals) and the soft starter is not showing any LEDs, please contact your distributor for support.

5.4.2 Flashing Phase LED

- i. A flashing phase LED indicates that the phase rotation of the 3-phase supply is wrong. Switch off the main circuit breaker and swap the incoming lines so that Line 1, Line 2, Line 3 is connected to the Power terminals in that order.

5.4.3 Mode LED flashing at 0.5Hz

A Mode LED that is flashing at 0.5 Hz indicates that the soft starter is in Error Mode and the ERROR LED will show a flash pattern as described below. Use this table to determine the cause of the fault.

	<p>The Error LED provides feedback on error conditions. When no error condition is detected, this LED will be off. When an error is detected the LED will repeat a sequence of flashes specific to the error condition. The sequence will consist of a number of 0.5s-on and 0.5s-off flashes, followed by an off-period of 1.5s. The table below describes the number of flashes for each error condition.</p>		
	Flashes	Error	Description
	2	Motor underload	A motor underload condition (MULC) is detected, with the motor current falling below a configured percentage e.g. 10% of the rated motor current for a period of more than 60 seconds.
	3	Line voltage	Over- or under voltage condition detected on the input voltage lines or a brown-out condition was detected.
	4	Frequency	Detected frequency differs from expected frequency by more than 5%.
	5	Over current (start)	Current exceeds the configured current limit during ramp-up.
	6	Ramp Up Time	Total ramp-up time exceeds the limit configured. This includes the periods where ramping is halted due to the current limit being reached.
	7	Motor overload	The motor protection curve for the configured protection class was violated.
	8	Over current (running)	Current exceeds the set current for the motor or soft start limit.
	9	Supply voltage unbalanced	Voltage levels on input lines differ from each other with more than 20%.
	10	Switching element	Current flow detected in a line where the switching element is switched off, or no current flow when the switching element or bypass contactor should be conducting.
	11	Internal temperature high	Internal temperature of the soft starter is high and caused the soft starter to trip.
	12	Motor temperature too high	Motor temperature is high and caused the soft starter to trip to protect the motor.
	13	Bypass contactor not present	The soft starter is configured for a bypass contactor, but the contactor did not close (when switching over after the start-ramp is completed).

5.4.4 Phase detection

- i. Switch the main supply off.
- ii. Measure to ensure that all three phases of the supply voltage is present. Check Circuit breaker and measure continuity through the fuses on each phase.
- iii. Switch main supply on.
- iv. Verify that the Phase LED comes on and stays on (not flashing).
- v. Confirm that the phase rotation is the same as the configured phase rotation on the PC Application (the default phase rotation in Clockwise)
- vi. Re-try starting the motor.
- vii. If this error occurs repeatedly and all other checks are done, contact your distributor.

5.4.5 Motor underload

- i. Check the motor and the load. This error typically occurs on e.g. a pump application when the pump is running dry.

- ii. Check the Motor size setting (Rated Current% potentiometer) on the HMI panel and confirm that this is correct according to the manufacturers nameplate. (This setting can also be confirmed on the PC Application).
- iii. Adjust the Motor Underload percentage (MULC%) on the PC Application. The default is 10%.

5.4.6 Line voltage

- iv. Check the supply voltage levels. Measure all three phases and confirm that the supply voltages are within the limits of the supply voltage for the soft starter (refer Figure 4).
- v. If supply voltage is within limits while the motor is not running, start the motor and monitor the supply voltage while the motor is running. Measure the supply voltage at the soft starter GRID terminals.
- vi. If this error occurs repeatedly and all other checks are done, contact your distributor.

5.4.7 Frequency

- i. Check the supply frequency. Measure all three phases and confirm that the supply frequency is within the limits of the supply frequency for the soft starter (refer 10.1).
- ii. If supply frequency is within limits while the motor is not running, start the motor and monitor the supply frequency while the motor is running. Measure the supply frequency at the soft starter GRID terminals.
- iii. If this error occurs repeatedly and all other checks are done, contact your distributor.

5.4.8 Over current (start)

This error occurs during the start ramp.

- i. Check the motor nameplate for the full load current specification of the motor and re-check the soft starter continuous current rating as well as the maximum starting current for the MEdsoftstart soft starter.
- ii. Confirm that the maximum starting current of the MEdsoftstart soft starter for the duty required by the installation, is at least three times the motor full load current (refer paragraph 1.1.1)
- iii. If possible, connect the PC Application to the Modbus RTU connector on the soft starter and read back the configuration (refer par 82). The PC Application will numerically display the configuration of the soft starter so that it is easy to see where the problem lies.
- iv. Confirm that the 'Rated Current%' potentiometer is set correctly for the size of the motor (refer paragraph 5.2 above).
– If the motor size is wrong, the soft starter will apply an incorrect ramp during start-up.
- v. Check the setting of the 'Start current' potentiometer. Turn this potentiometer up to allow for a higher starting current. A typical start current is between 400% and 200% of the Motor Full Load current.
- vi. Check the Normal/Heavy setting – When Heavy duty is selected, the soft starter will limit the starting current.
- vii. Confirm that the Normal / Inside Delta switch setting is correct for the installation – When Inside Delta is selected the soft starter will limit the current to 58% of the required current for the selected motor size.
- viii. Confirm that the Start Ramp starting% is not too high for the configured motor size. 60% may be too high for a small motor especially when wired as inside delta.
- ix. If changing the settings does not fix the problem contact your distributor for advice.

5.4.9 Ramp up Time

A trip on Ramp-Up time is an indication that the motor takes too long to start with the Soft starter configuration.

- i. Make the 'Start Ramp' longer

- ii. Make the 'Start Current' higher.
- iii. Make the 'Start%' higher.
- iv. If none of these actions resolve the problem, check the motor nameplate for the full load current specification of the motor and re-check the soft starter continuous current rating as well as the maximum starting current for the MEdsoftstart soft starter and contact your distributor for advice.

5.4.10 Motor overload

This error is related to the Motor protection class. The default protection class is 10. If this causes an error, confirm that the motor and wiring is correct and check with the motor manufacturer if the protection class may be changed to 20 or 30 using the PC Application.

5.4.11 Over current (running)

- i. Check the wiring to the motor.
- ii. Check that the motor temperature is not too high.
- iii. Confirm that there is no overload on the motor.

5.4.12 Supply voltage and current imbalance

- i. The default permitted supply voltage imbalance amongst phases is 20% (refer paragraph 5.2.1). Measure the imbalance and if below 25%, use the MEdsoftstart PC app to change the imbalance percentage to 25% if the motor specification permits that. If more than 20%, contact your plant electrician to check and try to balance phase loading for the plant.
- ii. The default phase current imbalance is 10% (refer paragraph 5.2.1). This can be set to 20% maximum using the MEdsoftstart PC application if the motor specification permits it.

5.4.13 Switching element

This error indicates a hardware fault inside the soft starter. Contact your distributor.

5.4.14 Internal temperature high

This error occurs when the temperature inside the soft starter is too high. The soft starter will trip and only allow a restart again when the soft starter has cooled down to room temperature.

- i. The error may occur because of overuse of the JOG function.
- ii. A long start-up ramp time on a motor with heavy load will also cause a temperature trip. Configuring the soft starter for Heavy Duty (refer paragraph 5.3 above) for a lower limit during the start ramp, may cure the problem. Re-confirm the motor size and starting current for Heavy Duty in
- iii. Table 1 or Table 2 above.
- iv. If there is no overuse or abnormal load or environmental conditions that may contribute to this issue and the soft starter repeatedly trips on this error, please contact your distributor for advice.

5.4.15 Motor temperature too high

This error occurs when the temperature on the motor is higher than the 'Maximum Motor Temperature' that is configured (refer paragraph 5.2.1). The soft starter will trip and only allow a restart again when the motor has cooled down to below the configured 'Motor restart temperature'.

- i. The error may occur because of overuse of the JOG function.
- ii. Check the motor.
- iii. Check the load.
- iv. If there is no overuse or abnormal load or environmental conditions that may contribute to this issue and the soft starter repeatedly trips on this error, please contact your motor supplier for advice.

5.4.16 Bypass contactor not detected

This error occurs where the soft starter is configured for a bypass contactor which is not present or not working as it should. After the start ramp is completed, the soft starter closes the bypass relay and then switches off the SCRs (in which case the motor will coast to a stop when it should be running, and will switch on hard when it should be stopping if the bypass contactor is not in place).

- i. This is most probably a configuration error – if the bypass contactor is not present, ensure that the dip switch on the HMI is in the correct position showing that a bypass contactor is not present.
- ii. The error may be due to a wiring problem where the bypass contactor is not being activated when the start ramp is completed. Refer to Figure 28.
- iii. Confirm that the soft starter output is functioning correctly: First configure for no bypass contactor and start the motor. Measure the Bypass output on the green connector X1. This contactor should be closed when the start ramp is completed. (Note that this switching of the relay happens in any case – whether configured for bypass or not).
- iv. Confirm that the Contactor is functioning correctly and that it does close when an appropriate activation signal is applied.
- v. If the soft starter is malfunctioning, please contact your distributor for support.

5.4.17 No communication on Modbus interface

If a Modbus Master device is connected to the RTU (RS485) Modbus port on the Core variant soft starter, the soft starter should start communicating when polled for data. The Power LED should start flashing faster at 1Hz (refer paragraph 5.1), indicating that communication with the Modbus master has been established. The default settings for the RTU Modbus interface is as specified in paragraph 10.1, with a Modbus address of 1.

- i. Check the communication settings on the Modbus master and confirm that they are correct.
- ii. If the Modbus master is running on a PC, ensure that the correct drivers for the Modbus RTU (to USB) cable is installed on the PC.
- iii. If it is possible that the Modbus settings on the soft starter-side have been changed or tampered with, do the following to restore factory defaults on the Modbus settings:
 - a. Switch power off;
 - b. Unplug all Modbus RTU cables;

- c. Press and hold the Reset button for 20 seconds while switching power on. The four LEDs will flash together once indicating that the factory restore has been completed;
 - d. Release the reset button;
 - e. Retry the Modbus communication with the default communication settings and address of 1.
- iv. If the Modbus Master is not the MEssoftstart PC application, test the communication first with the MEssoftstart/I Core variant PC application (refer paragraph 7.1).
- v. Replace the cable with a supplied Modbus RTU cable. Install the provided drivers (refer paragraph 7.1.1.1) and test again with the MEssoftstart/I Core variant PC application
- vi. If the interface still does not work, contact your distributor for support.

6. BASIC OPERATION – PRO MODELS

This chapter explains the configuration and the basic operation of the full-featured pro variants Industrial soft starter

⚠ This chapter explains the operation and use of this product. Always read the instructions before using the equipment.

6. BASIC OPERATION – PRO MODELS	62
6.1 OPERATIONAL MODES OF THE SOFT STARTER.....	63
6.2 POWER-UP THE SOFT STARTER	64
6.3 METHOD OF VIEWING AND CHANGING CONFIGURATION PARAMETERS	64
6.4 PARAMETERS.....	65
6.5 PARAMETER INTER-DEPENDENCIES.....	75
6.6 BASIC OPERATION PROCEDURE - OPERATION FROM TFT DISPLAY PANEL	76
6.7 BASIC OPERATION PROCEDURE – OPERATION FROM A REMOTE CONTROLLER	79
6.8 USING THE AUTO/MAINTENANCE-FEATURE	81

6.1 Operational modes of the soft starter

On power-up, the soft starter will be in IDLE mode. The user will be presented with a menu to Start the motor or to make the selection to enter a configuration setup menu where parameters can be viewed and changed.

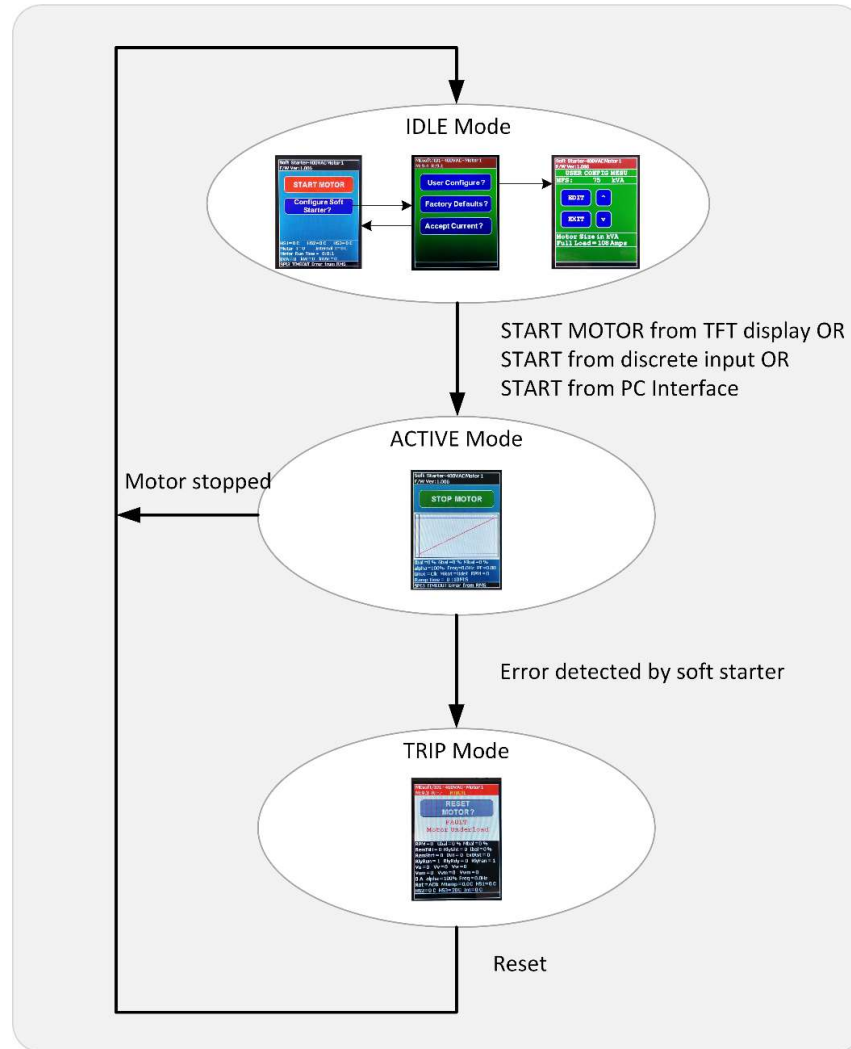

Figure 36 – Modes of operation of the soft starter

The soft starter can be configured via the TFT screen on the front panel or via the Modbus RTU or TCP interface using a SCADA system, or with the MEdsoftstart PC Interface. This section describes the configuration using the TFT screen. Refer to par 7.1 for an overview on using the PC Interface.

If the user selects to configure the soft starter, the user is presented with options to select a Factory Default Configuration (refer Table 18), or to create a User Configuration. In the case of a User Configuration, changes will be saved to the local non-volatile memory on the soft starter as the 'CUSTOM' configuration. The saved configuration (or CUSTOM configuration) then becomes the active parameter set that will be used whenever START MOTOR is selected.

The user may at any time revert to the pre-set Factory Defaults (refer Table 18). If the current configuration is unknown, the user may select to start with a Factory Default set of parameters and then make minor changes on that for a custom configuration.

6.2 Power-up the soft starter

At power-up the soft starter TFT display will present the user with the option to Start the motor (if the current configuration is known) or to configure the soft starter for the required language, size of the motor and settings for the application. Section 6.4 below explains the parameters that can be changed and how that influences the operation of the soft starter.

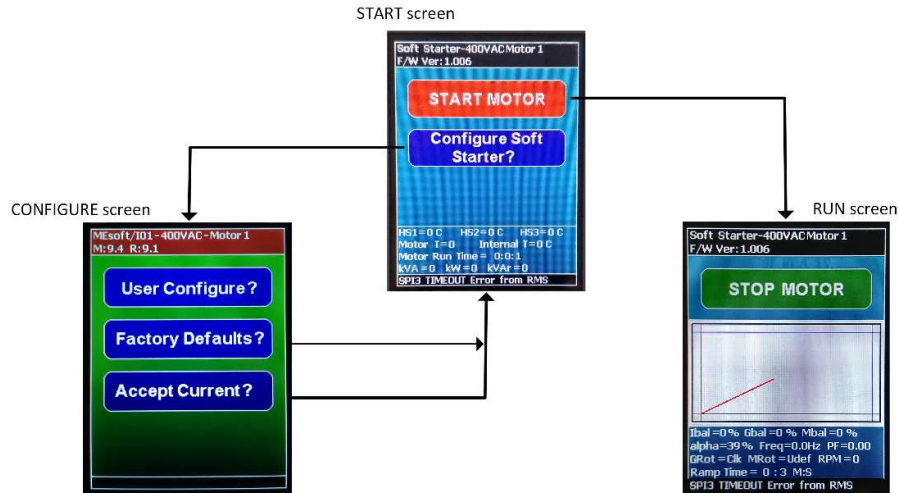

Figure 37 – Power-up the soft starter

6.3 Method of viewing and changing configuration parameters

Once in the parameter configuration screen the parameter can be viewed, changed and saved or changed and cancelled. The layout and usage of the PARAMETER screen and the EDIT screen are shown in Figure 38.

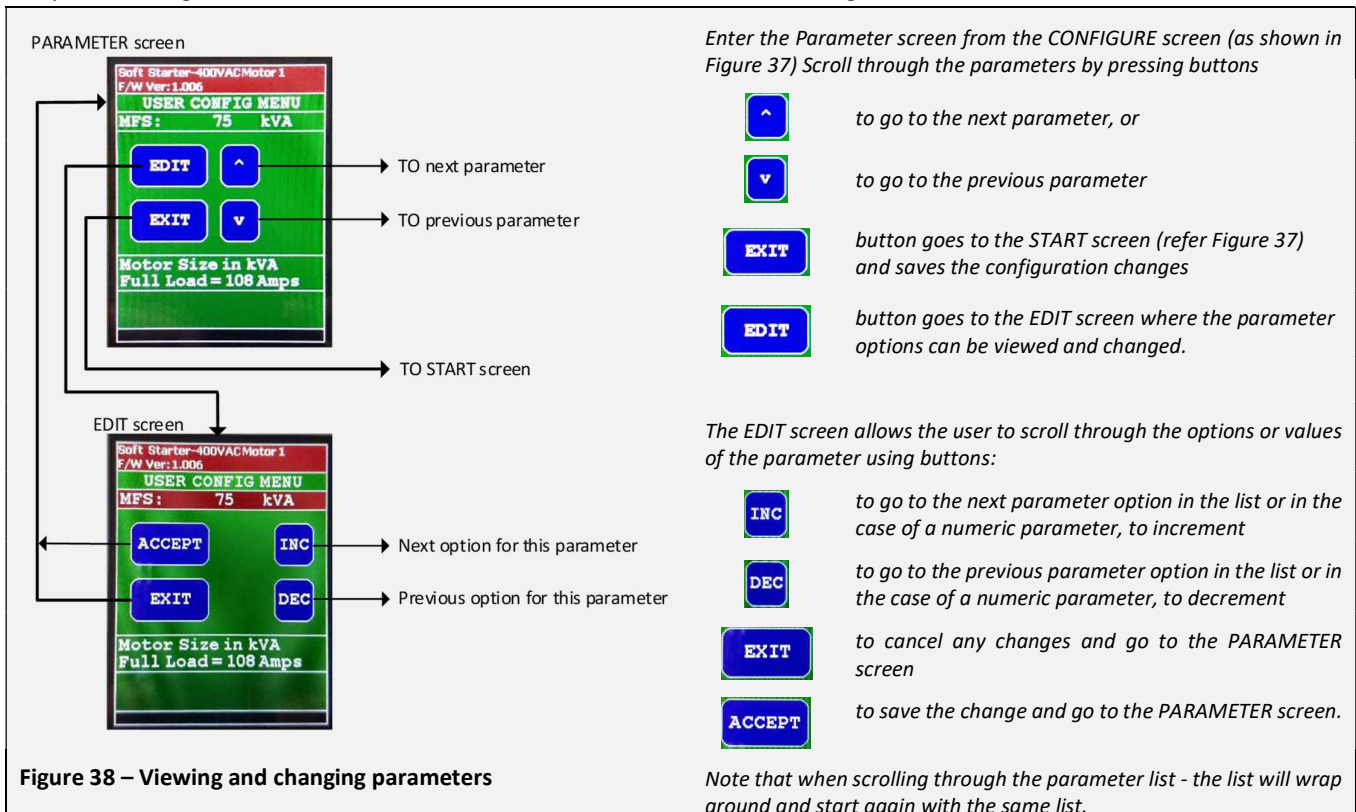







Figure 38 – Viewing and changing parameters



6.4 Parameters

This section explains configurable parameters. Parameters can be viewed and changed when the user selects to 'Configure the soft starter' and then selects 'User Configure' (refer Figure 37). A menu will be presented allowing the user to configure the soft starter as shown below.

Table 18: Configurable parameters of the soft starter

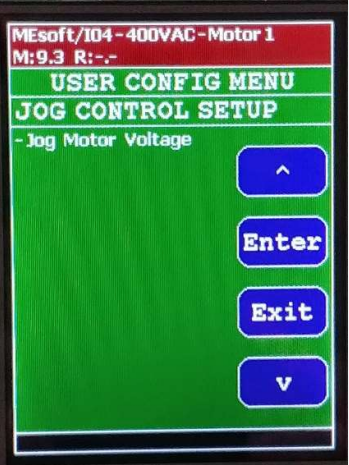
Reference	Parameter group	Parameters	Factory Default (where applicable)
6.4.1	Basic Setup – Motor Hardware	 <p>The screenshot shows a green LCD screen with a red header bar. The header bar contains the text 'MEsoft/104-400VAC-Motor 1' and 'M:9.3 R:-'. Below the header is the title 'USER CONFIG MENU'. The main menu is divided into two sections: 'BASIC SETUP' and 'MOTOR HARDWARE'. Under 'MOTOR HARDWARE', the following options are listed: '-RPM Sensor Presence', '-Protection Class', '-Phase Rotation', '-Motor Application', '-Motor Size kW', '-Bypass Contactor', '-Workload Norm/Heavy', and '-Inside Delta'. To the right of these options are four blue buttons: an up arrow (^), 'Enter', 'Exit', and a down arrow (v).</p>	<ul style="list-style-type: none"> • Inside Delta = No • Workload Norm/Heavy = Normal • Bypass Contactor = Absent • Motor Size kW (depends on frame size) • Motor Application = Default • Phase Rotation = Clockwise • Protection Class = 10 • RPM Sensor Presence = No
6.4.2	Basic Setup – Start Setup	 <p>The screenshot shows a green LCD screen with a red header bar. The header bar contains the text 'MEsoft/104-400VAC-Motor 1' and 'M:9.3 R:-'. Below the header is the title 'USER CONFIG MENU'. The main menu is divided into two sections: 'BASIC SETUP' and 'STARTUP SETUP'. Under 'STARTUP SETUP', the following options are listed: '-Maximum Starting Time', '-Ramp Up Time', '-Ramp Type Lin/RMS/S', and '-Start Type'. To the right of these options are four blue buttons: an up arrow (^), 'Enter', 'Exit', and a down arrow (v).</p>	<ul style="list-style-type: none"> • Start Type = Ramp • Ramp Type = Linear Time • Ramp Up Time = 10s • Maximum Starting Time = 60s (Normal Duty) or unlimited (30minutes - Heavy Duty)
6.4.3	Basic Setup – Stop Setup	 <p>The screenshot shows a green LCD screen with a red header bar. The header bar contains the text 'MEsoft/104-400VAC-Motor 1' and 'M:9.3 R:-'. Below the header is the title 'USER CONFIG MENU'. The main menu is divided into two sections: 'BASIC SETUP' and 'STOP SETUP'. Under 'STOP SETUP', the following options are listed: '-Ramp Down Time' and '-Stop Type'. To the right of these options are four blue buttons: an up arrow (^), 'Enter', 'Exit', and a down arrow (v).</p>	<ul style="list-style-type: none"> • Stop Type = Coasting • Ramp Down Time = 10s

Reference	Parameter group	Parameters	Factory Default (where applicable)
6.4.4	Advanced Setup		<ul style="list-style-type: none"> • Kickstart Voltage % = 60% • Kickstart Period = 0.2s • Constant Current % = 50% • Pedestal RampUp % = 20% • Pedestal RampDown % = 50% • MSC % = 200% • MULC % = 80% • MOLL % = 100% • Maximum Starts/Hour = 10 • Ramp Start Angle % = 0% • Alpha Skip Start % = 36% • Alpha Skip Stop % = 36% <p>Note that same value for Skip Start and Stop implies that the Skip is disabled.</p>
6.4.5	Temperature Setup		<ul style="list-style-type: none"> • Heatsink Fan Control = No • Maximum Motor Temp = 120°C • Heatsink Restart Temp = 40°C • Motor Restart Temp = 45°C • Heatsink Fan Start = 40°C • Motor Temp Selection = PT100 <p>Note: TMotor indicates that the LM35 sensor is selected.</p>
6.4.6	Jog Control Setup		<ul style="list-style-type: none"> • Jog Motor Voltage = 0 (Jog disabled)

Reference	Parameter group	Parameters	Factory Default (where applicable)
6.4.7	Supply Tolerances		<ul style="list-style-type: none"> • Max Volt Imbalance = 20% • Max Current Imbalance = 10% • Nominal Grid Voltage = 400V <p>Note that changing the nominal grid voltage requires the installer to ensure that all connected contactors (Bypass etc) have their coils updated to the same voltage level or damage to the coils will ensue</p>
6.4.8	General Setup		<ul style="list-style-type: none"> • User Language = English • Motor Name = 'Motor1' • Local/Remote Mode = Local • Password Edit = 0 (disabled) • Fault / Incoming CB = Fault
6.4.9	Communication Setup		<ul style="list-style-type: none"> • RS485 Baudrate = 115200 • RS485 Parity = Even • Modbus Slave Address = 1 • TCP/IP Parameters • Own IP address = 192.168.0.15 • IP subnet mask = 255.255.255.0 • Client IP address = 192.168.0.16 • Gateway address = 192.168.0.1

6.4.1 Basic Setup – Motor Hardware

The parameters that can be configured under this group are:

Parameters	Description - with options or range
Inside Delta Connection	<p>This parameter defaults to Normal connection. If the Inside Delta option is selected, the soft starter will allow a wider range of motor sizes (since the current through each phase will be only 58% of the phase current for normal delta connection.)</p> <p>⚠ Do not select Inside Delta when the motor is wired for a normal 3-wire motor.</p>
Workload Norm/Heavy	<p>This parameter specifies whether the soft starter will be used for a Normal duty or Heavy duty application.</p> <p>Normal duty is defined as no more than 10 starts per hour (> 6 minutes between starts) and start ramp shorter than 30s. Heavy duty is defined as more than 10 starts per hour (<6 minutes between starts) or a start ramp 30s or longer.</p> <p>The implication of the load duty selection is described in paragraph 1.1.1.</p>
Bypass Contactor	<p>Default: Absent (for models without built-in bypass; Present for models with built-in bypass)</p> <p>This parameter specifies to the soft starter that the user installs an external bypass contactor for a MEsoftstart model that has no bypass contactor installed. If an internal bypass contactor is present, this parameter will be default 'Present'.</p> <p>Ensure that this parameter is correct since the soft starter will allow for a higher running current when a bypass contactor can be switched in after the start-up is completed. Setting this parameter incorrectly can cause damage to the soft starter and will cause unexpected behaviour such that the motor to coast to a stop once the start ramp is done, when Bypass is configured for but not present.</p>
Motor Size kW	<p>The range of motor frame sizes that may be started with the MEsoftstart model soft starter is dependent on the following parameters:</p> <ul style="list-style-type: none"> • Supply voltage • Inside Delta or Normal 3-wire connection • Load Duty (Normal or Heavy) • Bypass contactor present or not present <p>Depending on this configuration, motor sizes may be selected as specified in the tables for each MEsoftstart model in paragraph 1.1.1.</p> <p>The TFT display guides the user by presenting only the applicable list of motor sizes and by showing the typical motor full load current at a power factor of 0.8.</p> <p>The motor size or rated current can be found in the rating plate of the motor. Once the motor size is selected, the Max Full Load Current (MFLC) is automatically calculated and displayed.</p> <p>⚠ Check the motor rating plate and ensure that the correct motor size is selected here.</p>
Motor Application	<p>The typical applications for which the soft starter may be used, each has a pre-set factory default configuration. The supported applications are listed below.</p> <p>Notes:</p> <ol style="list-style-type: none"> <i>The user should select an application profile and then adjust parameters as needed. The selected configuration will be saved as the User configuration, which will be used to run the soft starter.</i> <i>If the user's application is not one of the listed applications, Select 'Pump' and set the parameters as required for the user's installation.</i> <i>The User configuration can also be modified if further adjustments are needed.</i> <ul style="list-style-type: none"> • Default (select this profile to keep the current configuration) • Fan • Pump • High pressure pump • Compressor • Conveyor Belt
Phase Rotation	<p>This parameter specifies the required direction of the incoming Grid Phase rotation. This can be set to [Clockwise, Anti-clockwise, Don't care]</p> <p>Note: <i>If set to either clockwise or anti-clockwise, then the incoming direction of phase rotation must be in the selected orientation or the motor will not start and the operator will be allowed to either correct the wiring or change the direction of rotation.</i></p>

Parameters	Description - with options or range
	<p>If set to "Don't care" the soft starter will allow the motor to start in the direction of the present direction of rotation of the phases.</p> <p>⚠ If the direction of rotation of the motor is important, the Phase Rotation should not be set to "Don't care". This bypasses the built-in protection that the soft starter provides.</p>
Protection Class	This parameter can take a value of 2, 5, 10, 20 and 30 and represents the tripping class for motor overload protection.
RPM Sensor Presence	This parameter should be set when a shaft sensor is fitted for the Soft starter to measure motor speed in RPM.

6.4.2 Basic Setup – Start Ramp

Parameters that specify the start-up ramp time for the motor are configured under this group:

Parameters	Description - with options or range
Start Type	This parameter defines the different starting types that may be configured for the motor. They are: [Ramp-up, Pedestal, Kickstart, Constant Current] These parameters can be configured in the Advanced Setup (refer paragraph 6.4.4).
Ramp Type Lin/RMS/S	<p><i>Note that this parameter is not used when Start Type is Constant Current</i></p> <p>This parameter specifies the Ramp type that will be used during motor start and stop. Options are [Linear Time, Linear RMS, and S-Curve]. Default is Linear Time. The selected profile will be applied to the motor during starting and stopping (Ramp, Kickstart or Pedestal)</p> <p>Adjusting the ramp type is an advanced feature of the soft starter.</p> <p><u>Linear RMS:</u> This setting implies that a linear RMS voltage will be applied to the motor during starting and stopping (Ramp, Kickstart or Pedestal). Linear RMS is shown in the graphs (the RED line)</p> <p><u>Linear Time:</u> This setting will result in the RMS voltage applied to the motor as shown in the graph (the BLUE line).</p> <p><u>S-Curve:</u> A Ramp type setting of 'S-Curve' will result in the RMS voltage that is applied to the motor as shown in the graph (the BLUE line).</p>

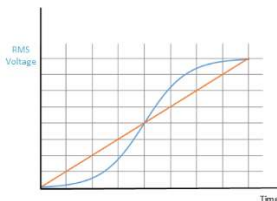
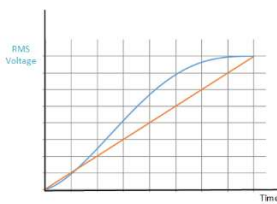

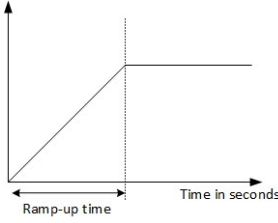
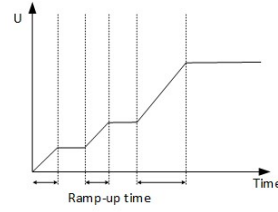
Parameters	Description - with options or range
<p>Ramp Up time</p>  	<p>This parameter defines the period during which the motor voltage, ramps-up. The parameter is adjustable between:</p> <p>[10 seconds – 60 seconds or the Maximum Ramp up time parameter].</p> <p>Note: The Ramp-up time is limited when Normal duty is selected.</p> <p><i>Note: The Ramp-up time can be extended by the current limiting functionality of the soft starter. In this case the Ramp-up time will be made up of the total time where the soft starter is ramping-up the output voltage. This ramp-up process will be cancelled if the Maximum Ramp-up time is exceeded.</i></p>
<p>Maximum Starting Time</p>	<p>This parameter defines the maximum period during which the motor may attempt to start within. The parameter is adjustable between:</p> <p>[10 seconds – 60 seconds] for Normal Duty [10 seconds – 1800 seconds] for Heavy Duty</p> <p>This time represents the maximum possible time that the motor could start in, which includes current limited delays incurred during the motor starting phase. If the motor has not achieved a Running status by the end of this time, the soft starter shall trip and display a fault.</p> <p><i>Note: This parameter cannot be set to a value less than the “Ramp-up time” above.</i></p> <p>⚠ Ensure to allow enough time to soft-start the motor within the limitation that is set. If the time is set too short, the soft start ramp will be aborted before reaching running speed.</p>

6.4.3 Basic Setup – Stop Ramp

Parameters that specify how the motor is stopped, are configured under this group:

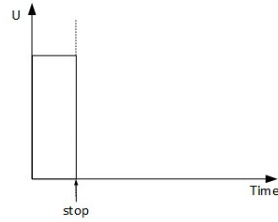
Parameters	Description - with options or range
<p>Stop Type</p>	<p>This parameter defines the 3 different stopping types that may be configured for the motor. They are: [Coasting, Ramp-down, Pedestal]</p> <p>These parameters can be configured in the Advanced Setup (refer paragraph 6.4.4).</p>
	<p><u>Coasting:</u></p> <p>In this mode, the Firing angle of the SCRs are instantly set to zero and the motor is allowed to coast to a stop.</p>

Parameters	Description - with options or range
Ramp Down Time 	<p>In this mode, the Firing angle of the SCRs decreases linearly from the maximum to zero with the Ramp up time.</p> <p>This parameter defines the ramp down time [10sec – 30seconds]</p>
	<p><u>Pedestal:</u></p> <p>In this mode, the firing angle drops immediately to a predefined pedestal level. It remains at this pedestal level until it intersects with the slope of a Normal Ramp down of the ramp down stop type. At that time, it continues linearly down until it reaches the zero value</p>
Pedestal Voltage	<p>This parameter determines the voltage amplitude of the pedestal voltage as a percentage of the nominal voltage. The parameter is selectable between [5% - 60%]</p>

6.4.4 Advanced Setup

Parameters that specify the motor current are configured under this group:

Parameters	Description - with options or range
Kickstart Voltage % 	<p>In this mode, the Firing angle of the SCRs has a brief step function that lasts for a defined period before returning to zero and then resuming a linear increase to the maximum value with respect to the Ramp-up time.</p> <p>This parameter determines the voltage amplitude of the kick-start voltage as a percentage of the nominal voltage. The parameter is selectable between [5% - 60%].</p>
Kickstart Period	<p>This parameter defines the period that the kick-start voltage is present for. The parameter can be set between [200ms - 2 Seconds].</p>
Constant Current % <i>This parameter is entered as a percentage of Max Full Load Current (MFLC) for the selected motor</i>	<p>In this mode, the soft starter will increase the voltage until the specified current is measured and then maintain the current for the duration of the maximum start time or until full voltage reached (i.e. the motor is running).</p> <p>This parameter specifies the constant current as a percentage of the Motor Full Load Current, that the soft starter needs to maintain during the starting of the motor.</p>

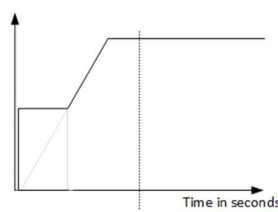
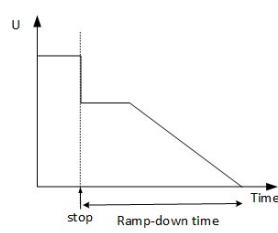
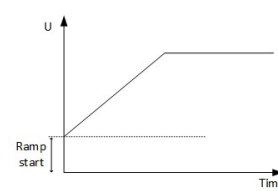
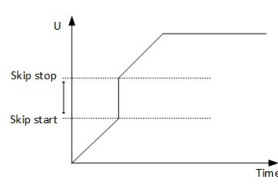
Parameters	Description - with options or range
<p>Pedestal RampUp %</p> 	<p><u>Pedestal:</u></p> <p>In this mode, the firing angle starts with a step jump to a defined level. It remains at this pedestal level until it intersects with the slope of a Ramp-up Start Type. At that time, it continues linearly until it reaches the maximum value.</p> <p>This parameter determines the voltage amplitude of the pedestal voltage as a percentage of the nominal voltage. The parameter is selectable between [5% - 80%].</p>
<p>Pedestal RampDown %</p> 	<p>In this mode, the firing angle drops immediately to a predefined pedestal level. It remains at this pedestal level until it intersects with the slope of a Normal Ramp down of the ramp down stop type. At that time, it continues linearly down until it reaches the zero value.</p> <p>This parameter determines the voltage amplitude of the pedestal voltage as a percentage of the nominal voltage. The parameter is selectable between [5% - 60%].</p>
<p>MSC %</p> <p><i>This parameter is entered as a percentage of Max Full Load Current (MFLC) for the selected motor.</i></p>	<p>The Maximum Starting Current (MSC) as a percentage of the Motor Full Load Current (MFLC).</p> <p>⚠ Read the label on the load. The maximum starting current should be selected to match the power requirement of the load (and not just selecting the maximum that the motor can handle e.g. a 15kW water pump that is powered by a 30kW motor).</p>
<p>MULC %</p>	<p>Motor Under Load Current (MULC) is specified as a percentage of MFLC. This parameter can be set between [0% - 100%] and is typically used to cause a trip when e.g. a pump is running dry and the load is subsequently drastically reduced.</p>
<p>MOLC %</p>	<p>Motor Over Load Current (MOLC) is specified as a percentage of MFLC. The parameter is adjustable between 100% and 600% or up to the maximum Frame size capacity which is measured as a percentage of Max Full Load Current (MFLC) for the selected motor as shown above e.g. :</p> <p>For a 45kW motor on a MEdsoftstart/I01, normal connection, no bypass contactor, the MOLC parameter range will be [100% - 589%].</p> <p>For a 110kW motor on a MEdsoftstart/I01 the MOLC parameter will be fixed at [100%-241%].</p>
<p>Maximum Starts/Hour</p>	<p>This parameter will limit the starts per hour to protect the motor and the soft starter.</p> <p>Note: The number of starts per hour is limited to 10 if Normal duty is selected.</p>
<p>Ramp Start Angle %</p> 	<p>This parameter sets the voltage level at which the ramp will begin (to bypass the start-up dead band). The value can be set between [0 – 35%].</p> <p>Note that this parameter is not applicable when Pedestal Start type is selected. If Kickstart-start type is selected, this parameter is applicable immediately after kickstart is completed.</p>
<p>Alpha Skip Start %</p> <p>Alpha Skip Stop %</p> 	<p>These parameters allow the user to configure the soft starter to, during ramping, skip over an area where the motor displays mechanical resonance (oscillation or vibration) This may be needed in a small or no-load start-scenario.</p> <p>The two parameters together define a band between [36% - 100%] where the voltage will jump.</p> <p>Note:</p> <ol style="list-style-type: none"> 'Skip stop' must at all times be greater than 'Skip start'. The soft starter configuration menu will enforce this. 'Skip start and Skip stop may not be further apart than 15%. Thus the maximum skip-jump will be 15%. The soft starter configuration menu will enforce this. If the 'Skip start' parameter is equal to the 'Skip Stop' parameter, no voltage jump is implemented.

6.4.5 Temperature Setup

These parameters specify the temperature limits that will be used by the soft starter to ensure the soft starter and the motor are operated within safe limits.

Parameters	Description - with options or range
Heatsink Fan Control	This parameter defines if the soft starter fan should be started when temperature becomes too high, or if the fan should always run during motor start, stop and run. Options are [Yes, No]. Default is 'No' (indicating that the fan will always run while stopping and starting).
Maximum Motor Temp	This parameter defines the maximum temperature at which the motor may operate. It is specified in the motor manufacturer's documentation. The allowed range for this temperature is dependent on the type of motor sensor that is configured and installed (refer 'Motor Temp Selection' parameter): <ul style="list-style-type: none"> 'Motor Temp Selection' = PT100, this parameter may be set between [90°C - 175°C]. 'Motor Temp Selection' = TMotor (LM35), this parameter may be set between [90°C - 115°C]. The default value is 115°C. ⚠ Important Note: <ol style="list-style-type: none"> When the motor temperature reaches 110% of this value, a warning will be displayed on the display unit. When the temperature reaches 120% the soft starter will trip and a fault will be displayed on the display unit.
Heatsink Restart Temp	This parameter defines the temperature to where the heatsink must cool down after a trip on excessive heatsink temperature, before the soft starter is ready for operation again. This parameter may be set between [30°C - 60°C] The default value is 40°C.
Motor Restart Temp	This parameter is applicable when the motor has tripped due to exceeding the "Motor Maximum Temperature". The parameter defines the temperature below which a restart may safely be attempted again. This parameter may be set between [35°C - 80°C]. The default value is 45°C.
Heatsink Fan Start	This parameter defines the temperature at which the heatsink fan must start and keep running. Below this temperature the Fan will stop running. This parameter is only applicable when 'Fan Temperature Control' is set to 'Yes' and may be set between [35°C - 50°C]. The default is 40°C.
Motor Temp Selection	This parameter configures the soft starter for use of the LM35 temperature sensor (option TMotor) or a PT100 sensor or no integrated motor temperature sensor. The PT100 sensor is the default selection.

6.4.6 Jog Control Setup

Jog Motor Voltage settings can be changed with the parameter in this group:

Parameters	Description - with options or range
Jog Motor Voltage	The soft starter provides the option to manually ramp-up the motor at a fixed voltage increment. This is typically used to test an installation or to do mechanical alignment and positioning of conveyor belts. This parameter defines the percentage of nominal voltage that is applied to the motor when the Jog function is operated. The parameter is settable between [0, 5%-80%]. 0 indicates that the 'JOG' option is disabled and a value of between 5% and 80% will ensure that the JOG option is available on the Start screen.



Parameters	Description - with options or range

6.4.7 Supply Tolerances

Parameters that specifies if Torque control should be used during starting and stopping of the motor and related parameters:

Parameters	Description - with options or range
Max Volt Imbalance	This parameter is the maximum percentage imbalance that can occur between the lowest and highest measuring phase voltages before a trip will occur. The parameter can be set between [15% - 25%]. The default is 20%.
Max Current Imbalance	The current imbalance is monitored while the soft starter in running (and not during Starting and Stopping). This parameter is the maximum percentage imbalance that can occur between the lowest and highest measuring phase currents before a trip will occur. The parameter can be set between [5% - 20%]. The default is 10%.
Nominal Grid Voltage	This value is factory set to the supply voltage for the model of soft starter and will be between 400V, 525V and 690V.

6.4.8 General Setup

The parameters that can be configured under this group are:

Parameters	Description - with options or range
User Language	Currently only English is supported for the HMI of the soft starter.
Motor Name	This is an alpha numeric string of up to 11 characters that may be used to identify the soft starter station. Default is "Motor1".
Local/Remote Mode	This parameter determines if the soft starter is controlled locally (either from the TFT display or a Modbus master such as the MEdsoftstart PC Interface) or remotely via external digital control inputs (e.g. a physical switch or a PLC). When 'Remote operation is selected, the TFT display will not activate the "START MOTOR" button, but instead will indicate that "REMOTE MODE" is active (with REMCTL in yellow to indicate that the remote device is in control of the soft starter operation).
Password Edit	The default Password is 0 – indicating that no password is active. If a password is required, this password may be set between 1 – 999999; and then a password will be required for all configuration operations. If the password is set and then lost, contact your distributor to unlock.
Fault / Incoming CB	This parameter configures the relay output on the green terminal X3-6,7 (refer Figure 26). When configured for FAULT relay, this output will be switched whenever a fault occurs When configured for Incoming CB, the output will be true when power is present at the soft starter.

6.4.9 Communication Setup

General parameters are configured under this group:

Parameters	Description - with options or range
RS485 Baudrate	The baud rate on the RS485 port. This parameter is applicable to the MEdsoftstart PC Interface as well as the Modbus RTU interface.

Parameters	Description - with options or range
RS485 Parity	The default parity on the Modbus RS485 port is Even parity. This may be set to Odd parity or No Parity.
Modbus Slave Address	The address of the soft starter on the Modbus link. The default address is 1. The address may be set between [1 – 247].
TCP/IP Parameters	Entering the setup will allow setting of the IP parameters for the Modbus TCP interface e.g. <ul style="list-style-type: none"> • Own IP address = 192.168.0.15 Port 502 • IP subnet mask = 255.255.255.0 • Client IP address = 192.168.0.16 • Gateway address = 192.168.0.1

6.5 Parameter inter-dependencies

Some parameters are only applicable when certain options are selected. The table below shows how the Start Type Configuration can be adjusted by changing some of the Advanced setup parameters.

Start Type ->	Ramp-up			Constant Current	Jog
	Advanced settings	Pedestal	Kickstart		
Ramp type	Linear RMS Linear Time				
	S-Curve	X	X	X	X
Ramp Up Time (Limited by Maximum Motor Start Time MMST)	Yes (<= MMST)			Equal to MMST	Fixed at 2s
Max Motor Start Time (MMST)	Yes	Yes	Yes	Yes	2 Secs
Kickstart Voltage	X	X	Yes	X	X
Kickstart Period	X	X	Yes	X	X
Constant Current %	X			Yes	X
Pedestal RampUp %	X	Yes	X	X	X
Pedestal RampDown %	X	Yes	X	X	X
MSC %				Yes	
MULC %				Yes	
MOLC %				Yes	
Maximum Starts/Hour (SPH)	NORMAL Duty: Starts per Hour =< 10, "Ramp Up Time" =< 30Sec and MMST =< 60. HEAVY Duty: Starts per Hour is 1 to 720 and "Ramp Up Time" and MMST, from 1 to 1800 seconds			NORMAL Duty: SPH =< 10; Ramp Up Time =< 60s; MMST =< 60	As often as required without tripping the Soft starter due to overload or over temperature
Ramp Start Angle	Yes	X	Yes	X	X
Alpha Skip Start %	Yes ³	(Yes ¹)	Yes	X	X
Alpha Skip Stop %	Yes ⁴	(Yes ²)	Yes	X	X

³ When skip zone is used in conjunction with Pedestal the pedestal percentage should be lower than the Skip Start % by at least 4%

⁴ When skip zone is needed, Skip Start should be less than Skip Stop by at least "0" (i.e. disabled) and at most 15%. When skip zone is not needed Skip Start and Skip Stop should be set equal (at any percentage between 36% and 100%)

6.6 Basic operation procedure - operation from TFT display panel

This section shows the basic operation of the soft starter when using the TFT display panel. Note that for operation from the TFT panel, the Modbus Controller (or MEsoftstart PC Application) should not be present and the Soft starter must be in LOCAL operation mode (refer par 6.4.8).

6.6.1 Understanding the information on the TFT display

The TFT display shows all the information that is required to understand the soft starter operation and do basic fault finding. The TFT display is small and compact notation is used to identify the parameters. Refer to Figure 39 below to understand the usage and interpretation of the Parameter display area.

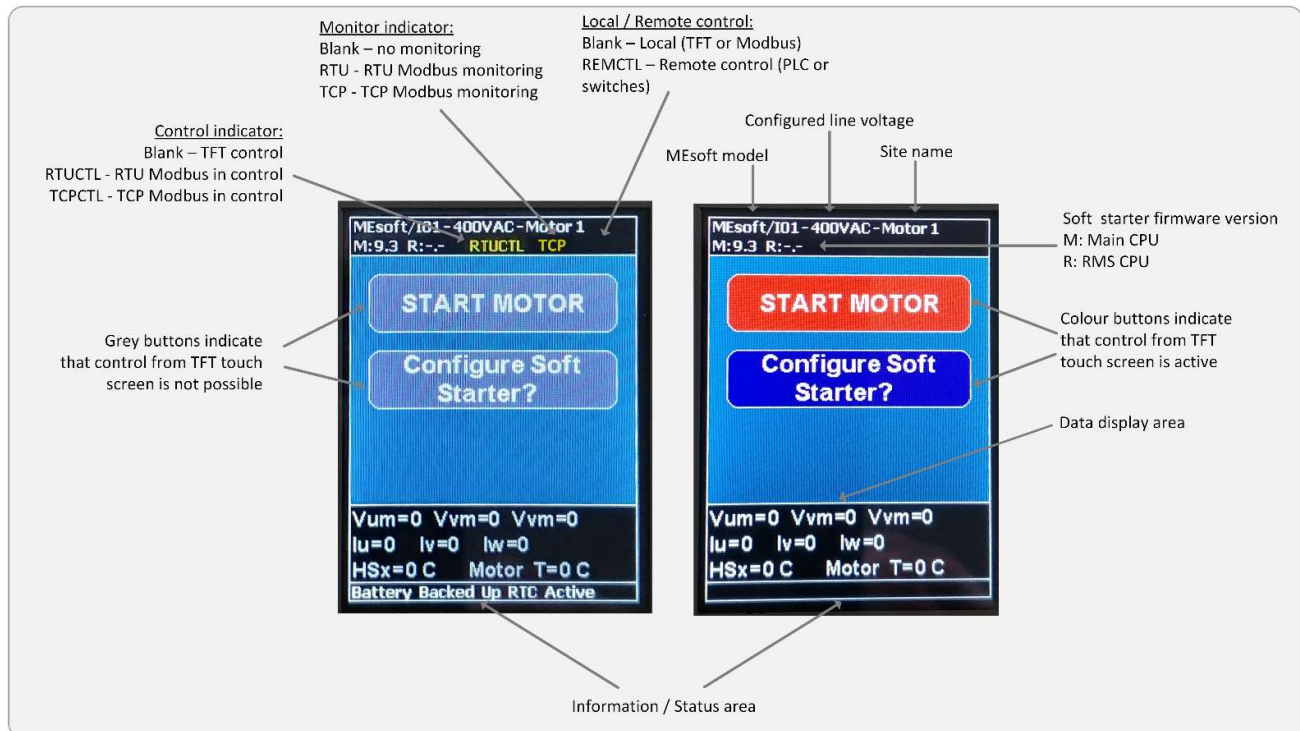

Figure 39 – Understanding the display areas

After power-up the Parameter display area cycles between parameter sets. The parameters sets are:

- i. Default parameter display,
- ii. General parameter display,
- iii. Temperature display,
- iv. Supply Status display,
- v. Voltage and Current measurement display,
- vi. Modbus and fan status.

The Default display is shown in Figure 39. The Information / Status area at the bottom indicates that the user may 'Touch and Hold' to stop the cycling and view a single parameter set, or to change to another data set. 'Touch and Hold' will stop the automatic cycling of parameter sets (shown in Figure 40) and will cycle manually between the data sets. After displaying the Modbus and fan status, the auto-cycling will resume.

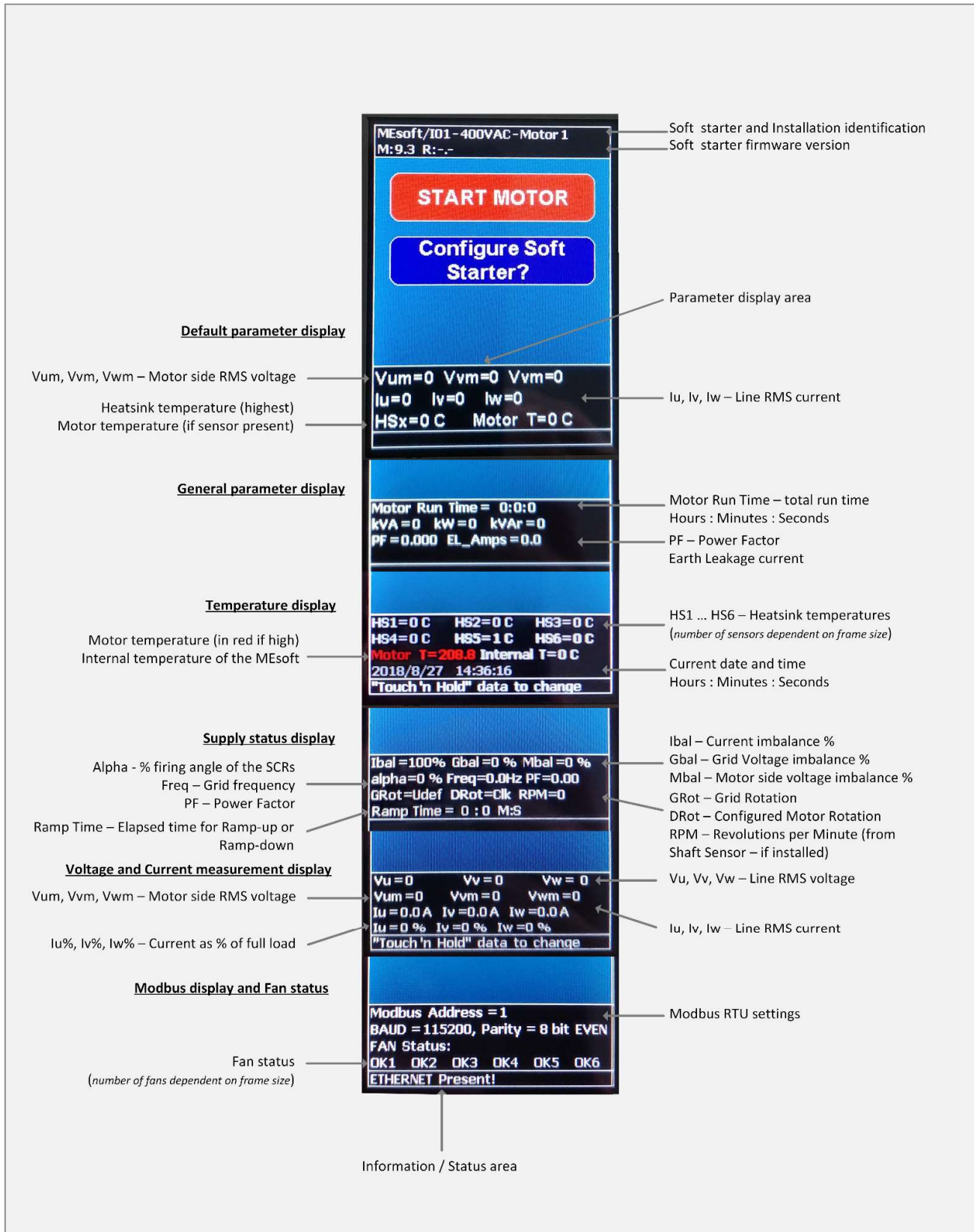

Figure 40 – Understanding the data display

6.6.3 Motor stopping

The motor may be stopped during the motor starting sequence or while it is running, by pressing the STOP MOTOR button.

When the STOP MOTOR button has been pressed, the voltage as a function of time is displayed on a stop progress screen. Note that the screen in Figure 41 shows a Ramp-down stop type. The display will depend on the selection as described in paragraph 6.4.3.

6.6.4 JOG operation from the operation panel

When a non-zero Jog Voltage has been configured (refer paragraph 6.6.4), the Start screen will appear as shown below:

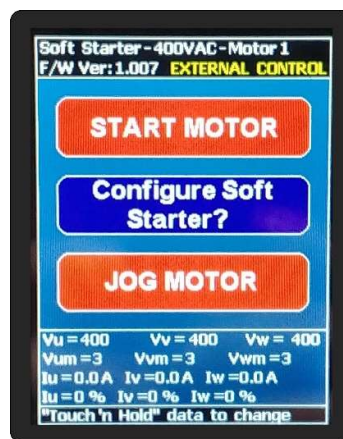

Figure 42 – Start screen with Jog option enabled

The motor may now be started by pushing the 'JOG MOTOR' button. While 'JOG' is active, the 'Alpha' value will increase resulting in an increased supply voltage being applied to the motor over a maximum time of 2 seconds. Pushing the 'JOG MOTOR' button again will cause the motor to coast to a stop.

If, while using the 'JOG MOTOR' button, the motor starts to exceed a comfortable speed, 'JOG MOTOR' can be pushed again and then pushed again when it is back at a comfortable speed. All motor tripping conditions are monitored during Jog and excessive running under Jog may sooner or later result in a trip.

6.7 Basic operation procedure – operation from a remote controller

This section shows the basic operation of the soft starter when using a remote controller such as a PLC. Note that for operation from a remote controller, the Soft starter must be in REMOTE operation mode (refer par 6.7.1). The Modbus Controller (or MEdsoftstart PC Application) may or may not be present but will only be able to monitor the soft starter or re-configure the soft starter when the motor is stopped.

Note that to be able to control the soft starter operation via a remote controller, the remote controller (or remote start button) must be wired on the soft starter (refer Table 14).

6.7.1 Selecting REMOTE operation







Configure the soft starter for remote control from the TFT display panel:	
Select to Configure Soft starter	
Select User Configure	
<p>Scroll through using the  button until the 'Operation' parameter is shown; and Edit the parameter. Set to 'Remote'.</p> <p>Be sure to  the change.</p>	 <p>Operation Mode</p>
<p>Press the  button twice to get to the start screen which should now show that the Operation Mode is "REMOTE"</p>	 <p>Soft starter is under remote control</p>

Figure 43 – Remote / Local Operation from the TFT display

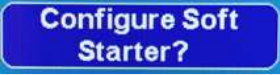
6.7.2 Start, Stop and Reset the soft starter from a remote controller.

The soft starter may be wired for remote operation and operation may then be controlled by closing the START contactor wired on X3-9 and X3-10 as shown in Table 14. The soft starter will commence to do the start ramp-up as configured (refer paragraph 6.6.2). When the START contactor is opened, the stop-ramp will commence. After completing the ramp-down, a delay will be implemented before starting is allowed again.

The delay is calculated to enforce the "Maximum Starts per Hour" that is set as described in par 6.4.4.

In case of a fault, remote Reset may be used to reset the soft starter. The RESET switch should be wired on X4-1 and X4-2 as shown in Table 15.

 Ensure to understand the nature of the problem before using remote reset. Refer paragraph 8.2 for more information.

6.8 Using the Auto/Maintenance-feature

The MSoftstart soft starter features an Auto/Maintenance input which may be used to prevent inadvertent START / STOP or RESET control of the soft starter from a remote location while e.g. maintenance is in progress.

Note that to be able to use the Auto/Maintenance function, the Maintenance switch must be wired on the soft starter (refer Table 14). Note that the Auto/Maintenance input on the soft starter must be normally closed (for the soft starter to be in Auto control to enable control from remote PLC, or any Modbus master, or the TFT panel). The Maintenance switch must open the Auto/Maintenance input on the soft starter to prevent remote control of the soft starter. When the Auto/Maintenance input is open, the soft starter will only accept control inputs locally on the soft starter, from the TFT panel.

- ⚠ The Auto/Maintenance feature must never be used in place of a proper safety procedure to ensure the safety of personnel working on the soft starter or the motor.

7. MESOFTSTART COMMUNICATION INTERFACE

This chapter introduces the MEssoftstart PC App for the MEssoftstart/I PRO variants and MEssoftstart/I Core variants, and explains how to install and use the software.

⚠ This chapter explains the operation and use of this product. Always read the instructions before using the equipment.

7. MESOFTSTART COMMUNICATION INTERFACE	82
7.1 MEsSOFTSTART PC APP	83
7.2 MEsSOFTSTART MODBUS INTERFACES	98

7.1 MSoftstart PC App

This section describes how to install the MSoftstart PC App on the user's computer and how to use the interface to configure, monitor and control the soft starter.

The MSoftstart PC App is tested to run on the Windows 10 operating system.

Two versions of PC Application software are available: for the Pro variants and the Core variants - the difference between the two is shown in the table below.

Table 19: MSoftstart PC App differences for Pro and Core variants

MSoftstart/I Pro variants	MSoftstart/I Core variants
Configuration	
The MSoftstart/I Pro variants are full featured soft starters that are highly configurable. The PC Application for the Pro variants are designed to make the complex configuration easy.	The MSoftstart/I Core variants are easy to use with configuration via potentiometers and switches. The PC Application for the Core variants allows the user to view the configuration (as set by the potentiometers and switches) and set limited configurable parameters (refer paragraph 5.2.1).
Monitoring	
The PC Application for the Pro variants provides real-time monitoring (while the motor is idle, starting, running and stopping).	The PC Application for the Core variants provides monitoring (while the motor is stopped or running but not while starting and stopping)
Control	
The Modbus link (PC Application, PLC or SCADA) allows Start, Stop and Reset control	
Interface	
The MSoftstart PC application for Pro variants can be used with Modbus RTU or Modbus TCP. - Modbus RTU interfaces on the RS485 RJ45 connector on J2 or J3 - Modbus TCP interfaces on the RJ45 Ethernet port on J1	The MSoftstart PC application for Core variants is based on Modbus RTU and interfaces on the RS485 RJ45 connector on J1 or J2.
Cable	
If the Modbus TCP interface is used, an Ethernet cable may be used to connect the PC with the soft starter.	If Modbus RTU is used a special cable is needed that converts the RS485 on the soft starter to a USB interface on the laptop. It is recommended to use the cable that is supplied to ensure that the supported buffer size of the converter is adequate.
Download the following version	
- MSoftstart/I Pro PC Interface Application (supports RTU and TCP) - If using Modbus RTU, the <i>Driver for Modbus Interface</i> is required	- MSoftstart/I Core PC Interface Application (supports only RTU) - <i>Driver for Modbus Interface</i>

7.1.1 Installing the MSoftstart PC App on a PC or laptop

The installation instruction for both PC applications, is the same. Ensure to download the correct zip folder for the MSoftstart/I Pro variant or the MSoftstart/I Core variant.

7.1.1.1 Copy the files to the PC or laptop

Copy the MSoftstart installation files can be downloaded from the Mitsubishi Electric Europe website (they can also be obtained from your distributor) to the hard drive of the PC or laptop that will be used for the MSoftstart configuration and monitoring. For the Core variant, and, if Modbus RTU is to be used for the Pro variant as well, a cable with RS485 to USB converter will be used. The drivers for the Modbus interface cable also need to be downloaded. If Modbus TCP will be used, the drivers are not required. Open the folder where the files are copied. The folder should look like Figure 44 :

<input type="checkbox"/>	Name	Date modified	Type
	Driver for Modbus interface	2018-04-02 17:59	File folder
	MEsoftI Core PC Interface Application	2018-09-12 13:56	File folder
	MEsoftI Pro PC Interface Application	2018-04-02 22:20	File folder

Figure 44 – MSoftstart Installation files on the user PC or Laptop

7.1.1.2 Run the PC application

Open the folder *MEsoftstart/I Pro PC Interface Application* or *MEsoftstart/I Core PC Interface Application* and double click on the '.exe' file to run the program.

<input type="checkbox"/>	Name	Date modified	Type	Size
	config	2018-09-12 13:56	File folder	
	data	2018-09-12 13:56	File folder	
	dump	2018-04-02 22:20	File folder	
	Error	2018-09-12 13:56	File folder	
	log	2018-04-02 18:21	File folder	
	platforms	2018-09-12 13:56	File folder	
	libEGL.dll	2016-12-01 12:33	Application extens	22 KB
	libgcc_s_dw2-1.dll	2015-12-29 00:25	Application extens	118 KB
	libGLSv2.dll	2016-12-01 12:33	Application extens	2 736 KB
	libstdc++-6.dll	2015-12-29 00:25	Application extens	1 505 KB
	libwinpthread-1.dll	2015-12-29 00:25	Application extens	78 KB
<input checked="" type="checkbox"/>	MEsoftI_Core_PC_Interface.exe	2018-03-28 09:19	Application	1 804 KB
	Qt5Core.dll	2018-01-03 16:52	Application extens	5 275 KB
	Qt5Gui.dll	2016-12-01 12:41	Application extens	5 159 KB
	Qt5PrintSupport.dll	2016-12-01 12:51	Application extens	355 KB
	Qt5SerialPort.dll	2016-12-01 15:04	Application extens	76 KB
	Qt5Widgets.dll	2016-12-01 12:49	Application extens	6 219 KB

Figure 45 – MSoftstart PC App files on the user PC or Laptop

The MEssoftstart PC App should run and the home screen should be visible (refer Figure 46).

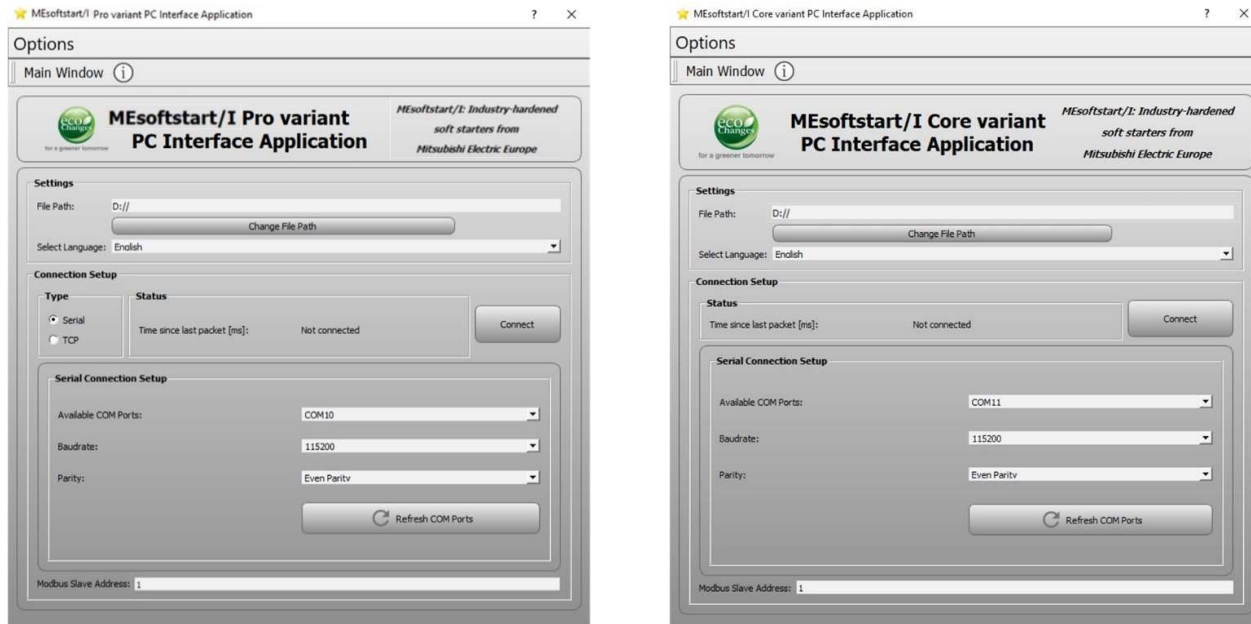



Figure 46 –Home screen with Modbus RTU setup selected

Once the MEssoftstart PC App is running, the Information screen can be accessed by clicking the _icon. The Information screen shows the software version and the supported MEssoftstart models.

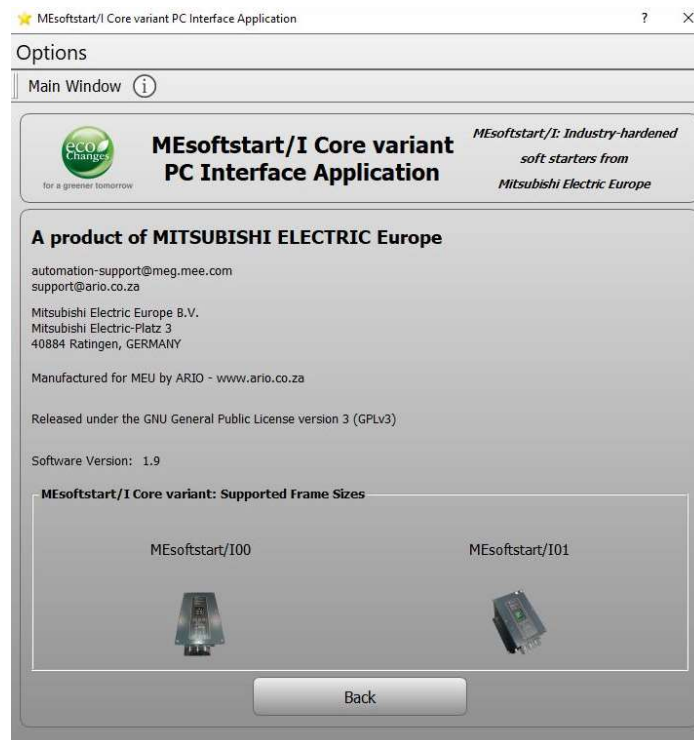

Figure 47 –Information screen

7.1.1.3 Modbus RTU – Test to see if a driver is required for the Modbus-USB cable

If Modbus TCP is being used, this step may be omitted.

Ensure that the Connection Setup-> Type is on 'Serial' to be able to view the serial Modbus RTU setup parameters. Click on the down arrow of the "Available COM Ports" drop-down box and make a note of all the COM ports listed.

Connect the computer to the MEssoftstart soft starter – using the cable provided.

- i. For the Pro variants: Ensure to connect to J2 or J3 on the bottom (motor-side) of the MEssoftstart enclosure.
- ii. For the Core variants: Ensure to connect to J1 or J2 on the top (grid supply-side) of the MEssoftstart enclosure

If the wires are long or communication quality is a problem ensure to use a terminating resistor on the other connector on the last soft starter in line (if they are daisy-chained) – refer paragraph 0.

Note: If the computer is connected to the internet and offers to find a driver for the new hardware, wait for it to complete the procedure. You may also point the computer to the driver in the "MEssoftstart Installation files\Driver for Modbus interface" folder (refer Figure 44).

If nothing happens or once the new driver installation is completed, click on the "Refresh COM ports" button and confirm that a new COM port was added to the drop-down list of "Available COM Ports".



Figure 48 – MEssoftstart PC Application detects the COM port of the Modbus-USB cable

If the new COM port is not automatically detected, close the MEssoftstart/PC Interface Application, remove the Modbus-USB cable. Install the provided driver, reconnect the Modbus-USB cable and start the MEssoftstart PC App again.

7.1.1.4 Modbus TCP

If the Core variant is used or the Pro variant with Modbus RTU is being used, this step may be omitted.

Ensure that the Connection Setup-> Type is on 'TCP' to be able to view the serial Modbus TCP setup parameters. Ensure that the IP Address is correct and the Port is 502. The PC or laptop should be set for a static IP address.

Connect the computer to the MEssoftstart soft starter using a normal Ethernet cable. Ensure to connect to J1 on top of (grid side of) the MEssoftstart enclosure.

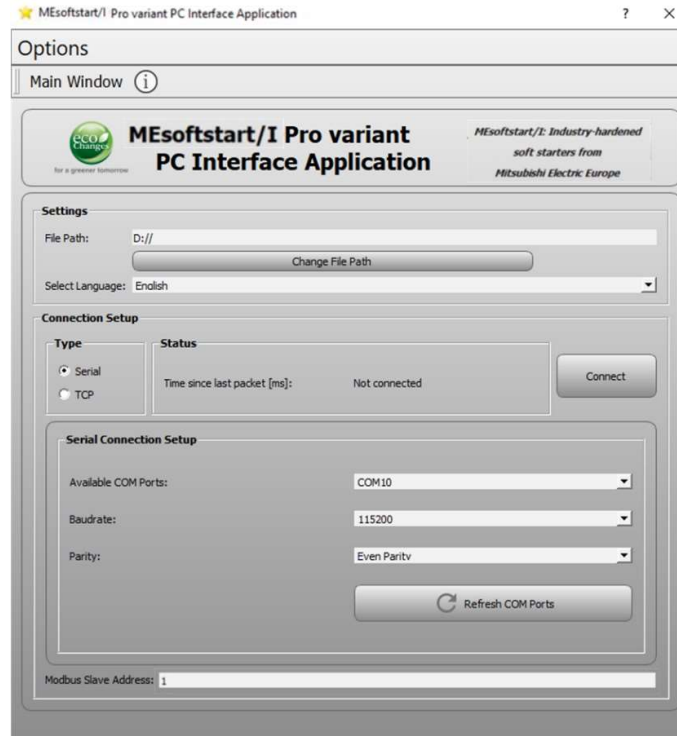

Figure 49 – MEssoftstart PC Application setup for Modbus TCP connection

7.1.2 Connecting to the soft starter

When the MEssoftstart/I PC Interface Application is running and the Ethernet cable or Modbus-USB cable is connected to a MEssoftstart soft starter that is powered-up, the "Connect" button can be clicked, to connect the computer to the soft starter.

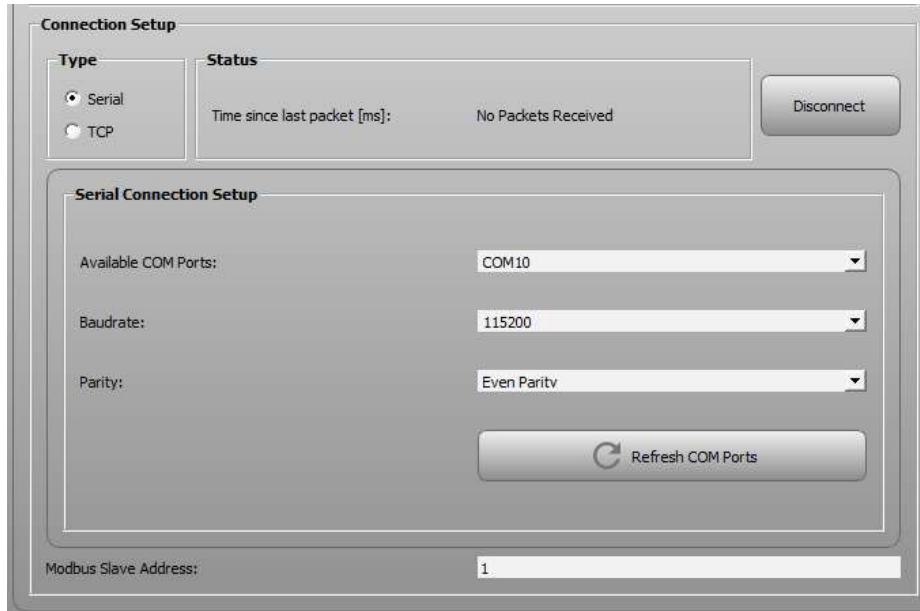

Figure 50 – MEsoftstart PC App on RTU Modbus waiting for communication from soft starter

If the MEsoftstart PC App is not connecting to the soft starter, it may be that the Modbus communication parameters or the Modbus Slave Address of the soft starter have been modified on the soft starter.

For the Pro variants: Refer paragraph 6.4.9 for information on how to check the TCP and RTU Modbus communication parameters and RTU address on the soft starter using the TFT display.

For the Core variants: Refer paragraph 5.4.16.

Once the communication parameters and RTU address on the soft starter and the MEsoftstart PC App are the same, try connecting to the soft starter again.

When first connected to the soft starter, the Start screen will be shown (refer Figure 51 for Pro variant Start screen).

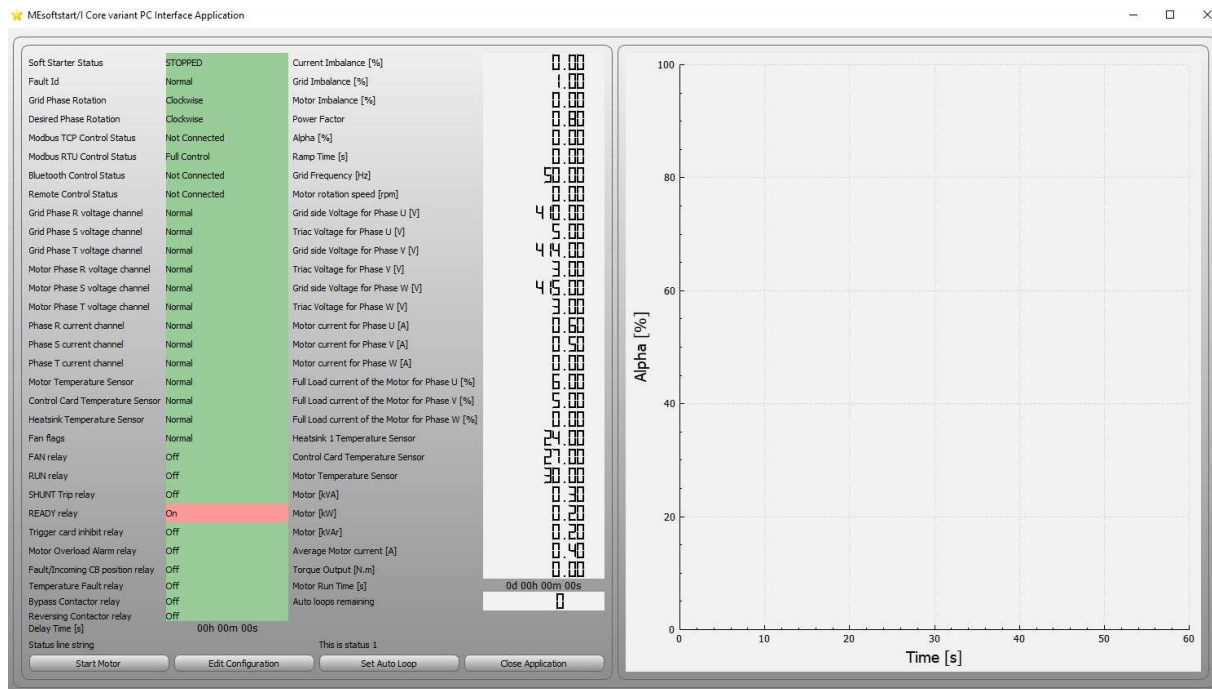

Figure 51 –PC Application for Pro variant - Start screen

On the Pro variants:

Once the MEdsoftstart PC App (or other Modbus controller) is connected, the soft starter TFT display will not accept command inputs (other than to toggle through the Parameter Display Area options). This will be clear to the user with the yellow text “TCPCTL” being displayed in the top right side of the TFT display – refer Figure 39.

To return control to the TFT display on the soft starter, close the PC application or disconnect the Modbus cable. After a delay of about 10 seconds, the TFT display will allow user inputs again.

Note that after power-up, the soft starter will only service the Modbus port once the configuration has been accepted on the TFT display. If the MEdsoftstart PC App shows that it has the communication port open but is not receiving data from the soft starter (refer Figure 50), check the TFT display on the soft starter and accept the configuration. Once this is done, the soft starter should commence Modbus communication and the Start screen (Figure 51) should be visible.

On the Core variants:

Once connected the MEdsoftstart/I Core variant Mode LED will flash faster (1Hz) to indicate that Modbus monitoring and Control is possible. Limited configuration is also possible (refer paragraph 5.2.1

- ⚠ Do not attempt to immediately start the motor – first view the configuration and confirm that the settings are correct for the user’s installation.

7.1.3 Configuring start and stop behaviour using the MEdsoftstart PC App

On the Core variant:

Configuration is mostly done on the Potentiometer HMI – refer paragraph 5.2 above. The configuration that the soft starter reads from the HMI inputs may be viewed on the MEdsoftstart/I Core PC Interface Application. In addition, advanced settings may be configured from the PC Application. Figure 52 shows a typical configuration screen for the Core model. Note how the ‘Ramp-up time’, ‘Maximum Starting Current Percentage’, ‘Rated Current’ etc. values are displayed but the fields are inactive for editing since these parameters are set on the potentiometers on the HMI panel.

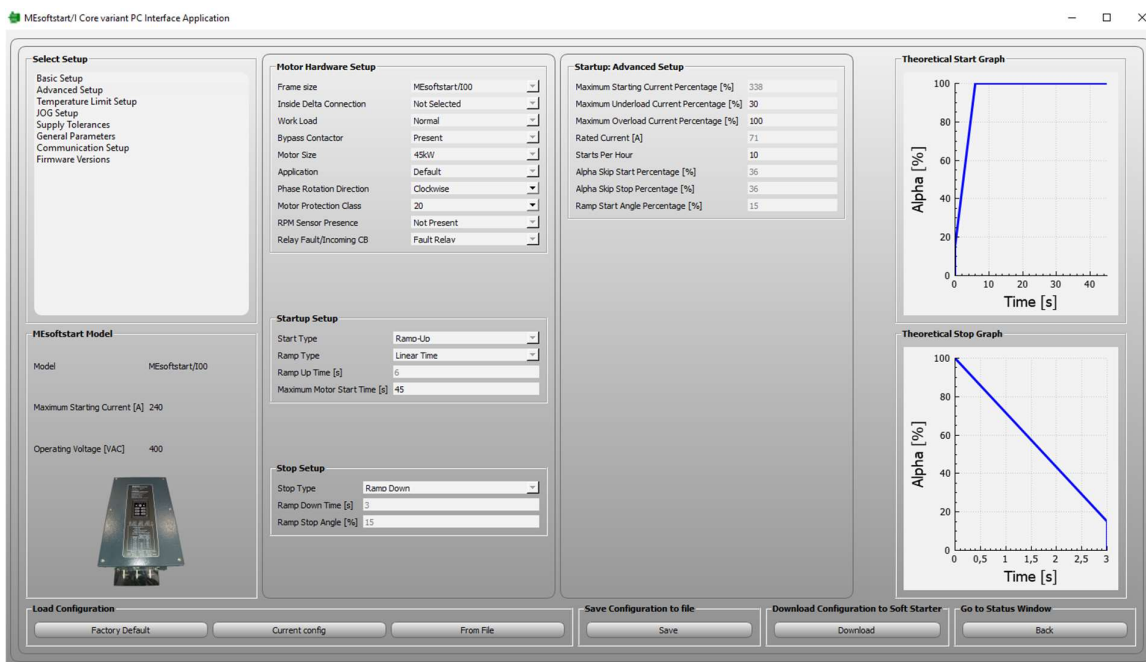

Figure 52 –PC Application for Core variant - Configuration screen

On the Pro variant:

The parameters that may be configured via the MEssoftstart PC App are the same parameters which are available for configuration via the TFT display.

From the Start screen select to “*Edit Configuration*”. The Configure screen will be shown with the “*Basic Setup*” parameters (refer Figure 53). Note that every time the MEssoftstart PC App connects to the soft starter, the current soft starter configuration is uploaded from the soft starter so that the PC Application configuration and the soft starter configuration will be the same.

- ⚠ When changes are made on the MEssoftstart PC App configuration screen, the configuration parameters are different from the actual configuration on the soft starter. The PC configuration and the actual soft starter configuration will only be the same again after a successful “*Download*” to the soft starter or when “*Current Configuration*” is selected to again upload from the soft starter (overwriting changes that were made on the Configure screen).

Note that all the parameters that are available on the configuration screen are the same as those that are listed for the TFT display configuration (refer **Table 18**). In addition, the MEssoftstart PC App shows the model of the connected soft starter and a theoretical representation of what the configured start and stop ramps will look like.

Select the “*Advanced Setup*” to view more detail parameters (refer Figure 53). Note that the “*Kickstart Setup*” parameters will only become available for editing once “*Start Type – Kickstart*” is selected. Similarly, the “*Constant Current Setup*” parameters are visible, but only available for editing when the “*Start Type – Constant Current*” is selected. The “*Pedestal Setup*” parameters are visible, but only available when the “*Start Type – Pedestal*” is selected.

Also take note of the parameter inter-dependencies as listed in paragraph 6.5. The PC Application will indicate which parameters are not applicable for the configured scenario, by making the parameters inactive (grey).

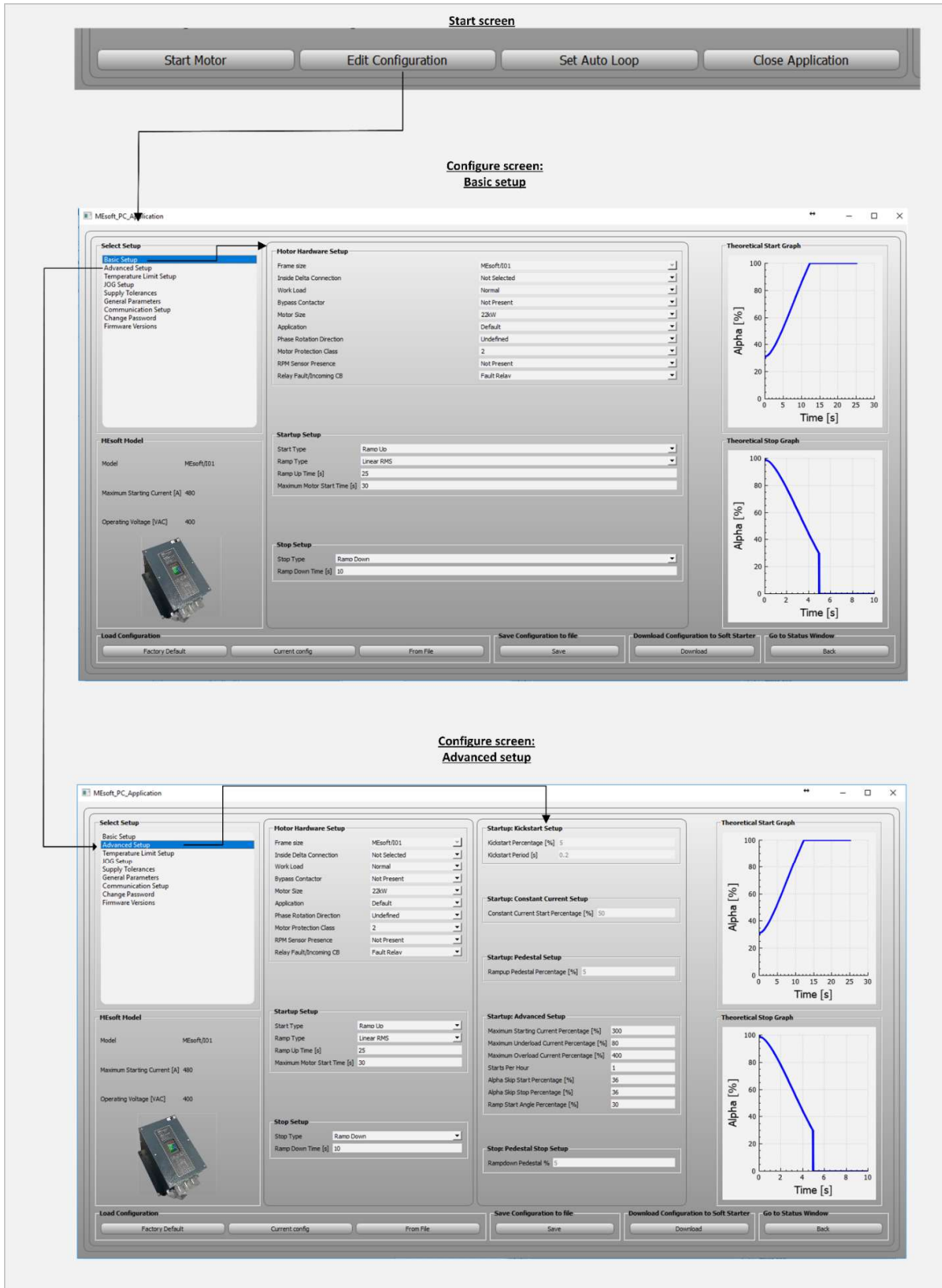

Figure 53 –Configure screen

When the configuration is acceptable, the user should select “Download” to save the configuration to the soft starter followed by “Back” to return to the Start screen. There is an optional password when downloading a new configuration to the soft starter. This is to prevent unauthorised changes to the soft starter. If the password is not in use the value ‘0’ will allow the

'download' action to continue. If the password was activated on the soft starter, the correct password will be required to download the configuration to the soft starter. Refer paragraph 6.4.8 for more information on the password.

The user may at any time revert to "Factory default" parameter set, or to the "Current Configuration" on the soft starter, or may load "From File" a previously saved configuration. (Refer Figure 54).

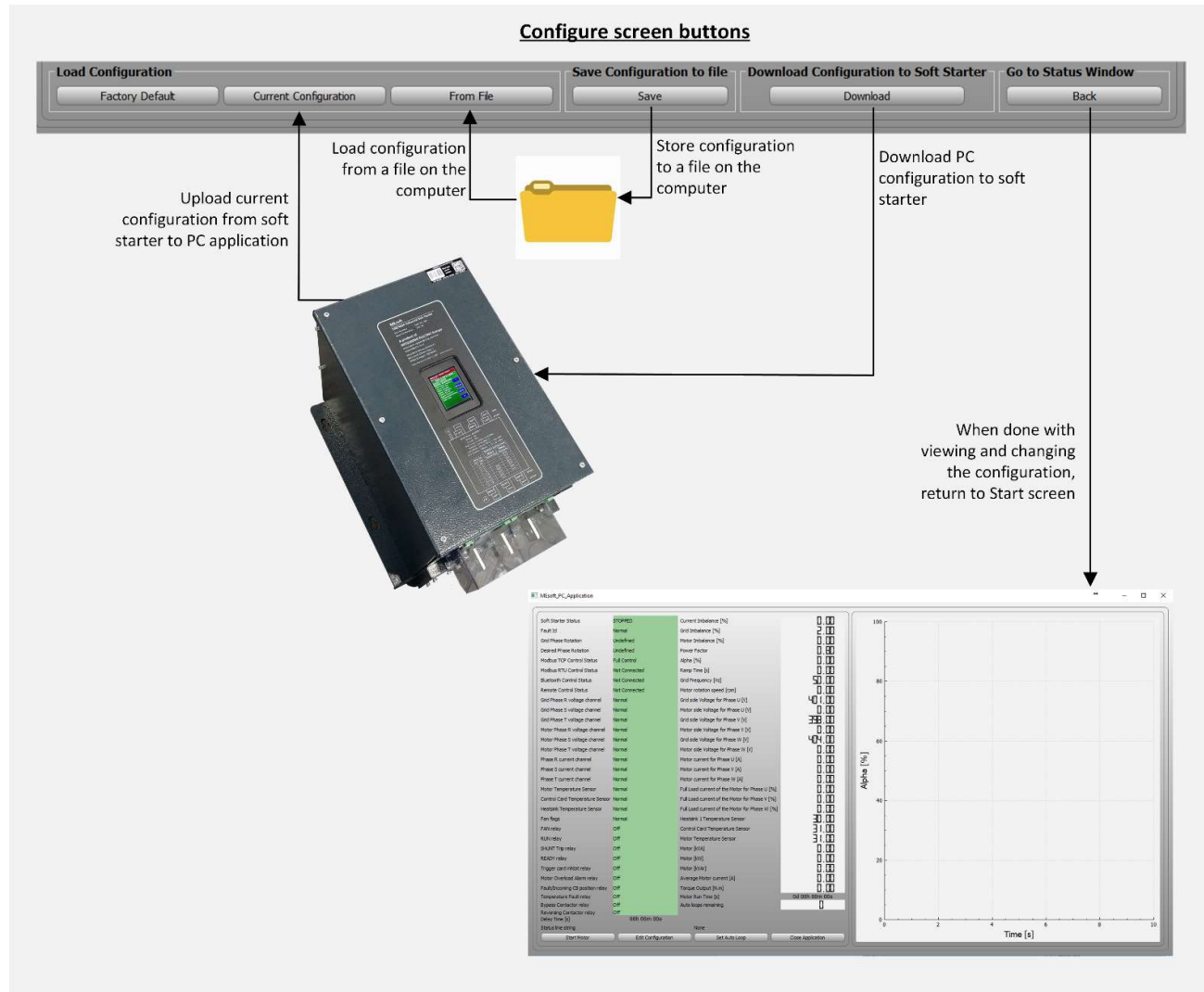

Figure 54 –Configure screen buttons

Note that the default "File Path" where the configuration files are saved can be changed from the Home screen (refer Figure 46).

7.1.4 Configuring limits and tolerances using the MSoftstart PC App

On the Core and the Pro variants:

The soft starter implements protection against over temperature on the motor and on the soft starter heat sinks, as well as supply voltage and current unbalance. These parameters should not usually be changed, but are available to the advanced user to adjust.

Note that the soft starter can control the internal fan to run whenever the motor is running. Or to start running when the heatsink temperatures are above a limit – "Heatsink Fan Start Temperature".

Temperatures, when the soft starter will trip to protect the motor or the switching electronics inside the soft starter, can also be adjusted.

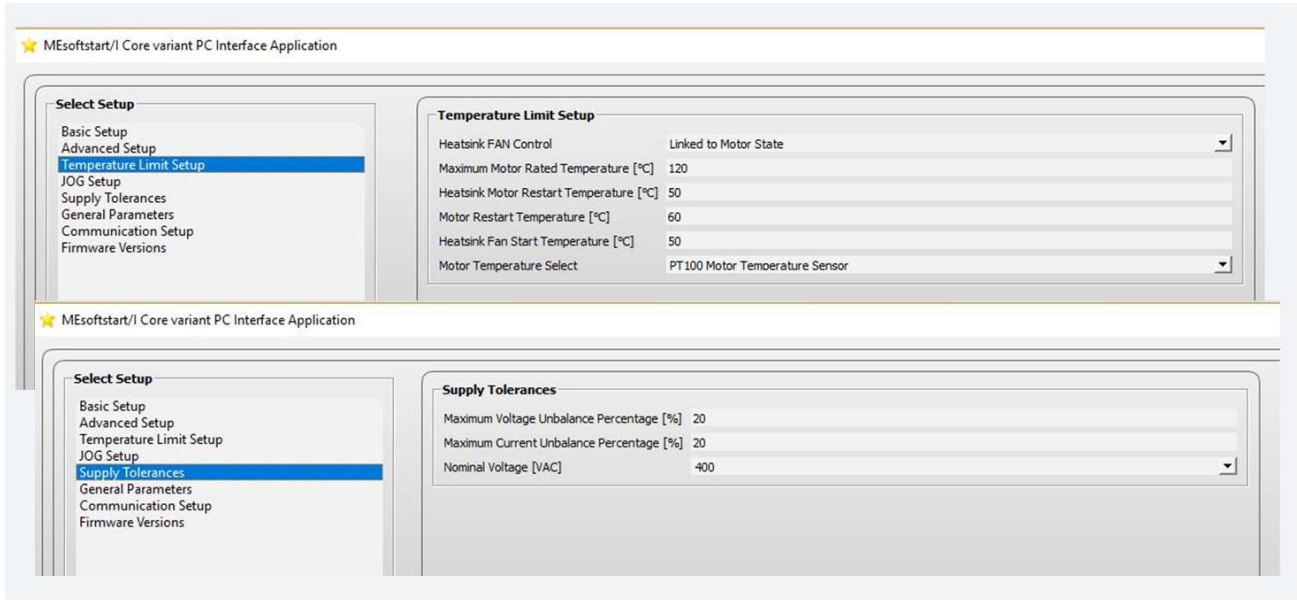

Figure 55 –Configure screen - limits and tolerances

7.1.5 Configuring general parameters and communication settings

On the Core and the Pro variants:

Just like on the TFT display, the MEsoftstart PC App may be used to configure general parameters and communication settings for the Modbus interface. Refer Figure 56 for an overview of what can be changed on these screens.

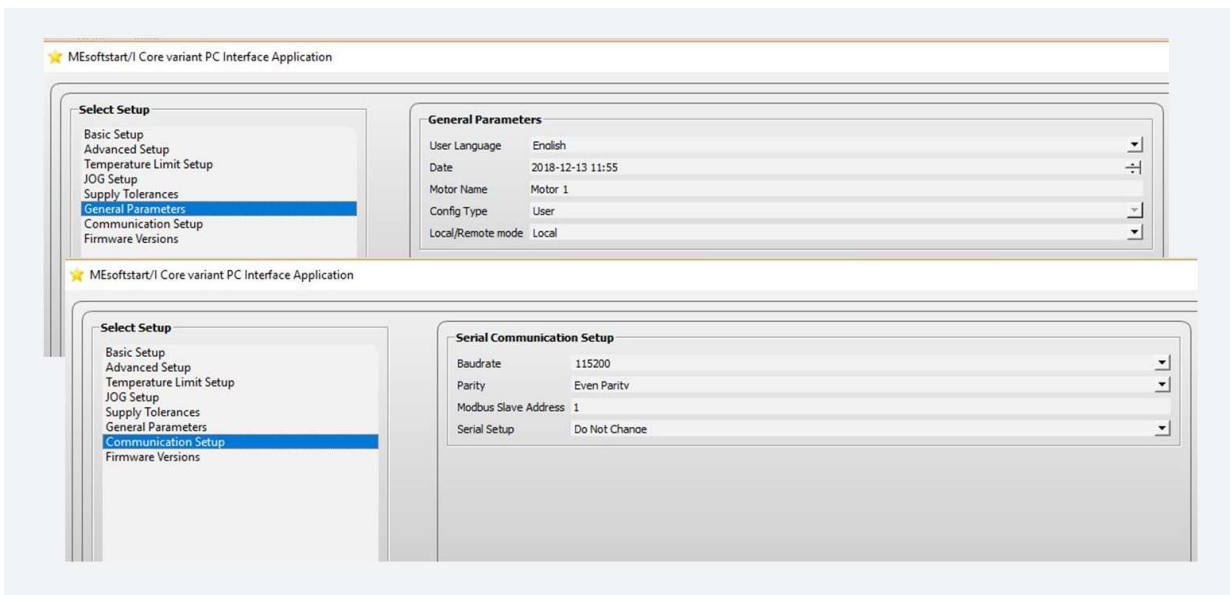

Figure 56 –Configure screen – general parameters and communication settings

7.1.6 Configuring for the JOG option using the MSoftstart PC App

On the Core variant: JOG is controlled from the HMI panel (refer paragraph 5.3.3)

On the Pro variant:

Just like on the TFT display the soft starter may be configured using the MSoftstart PC App to “JOG” the motor at a fixed voltage for testing or calibration purposes.

Once a configuration with a greater-than-zero “JOG Motor Voltage Percentage” is downloaded to the soft starter, JOG mode is available on the soft starter and from the PC application. If JOG mode is no longer needed, set the “JOG Motor Voltage Percentage” back to zero again. The JOG buttons on the PC application and the TFT display will be removed.

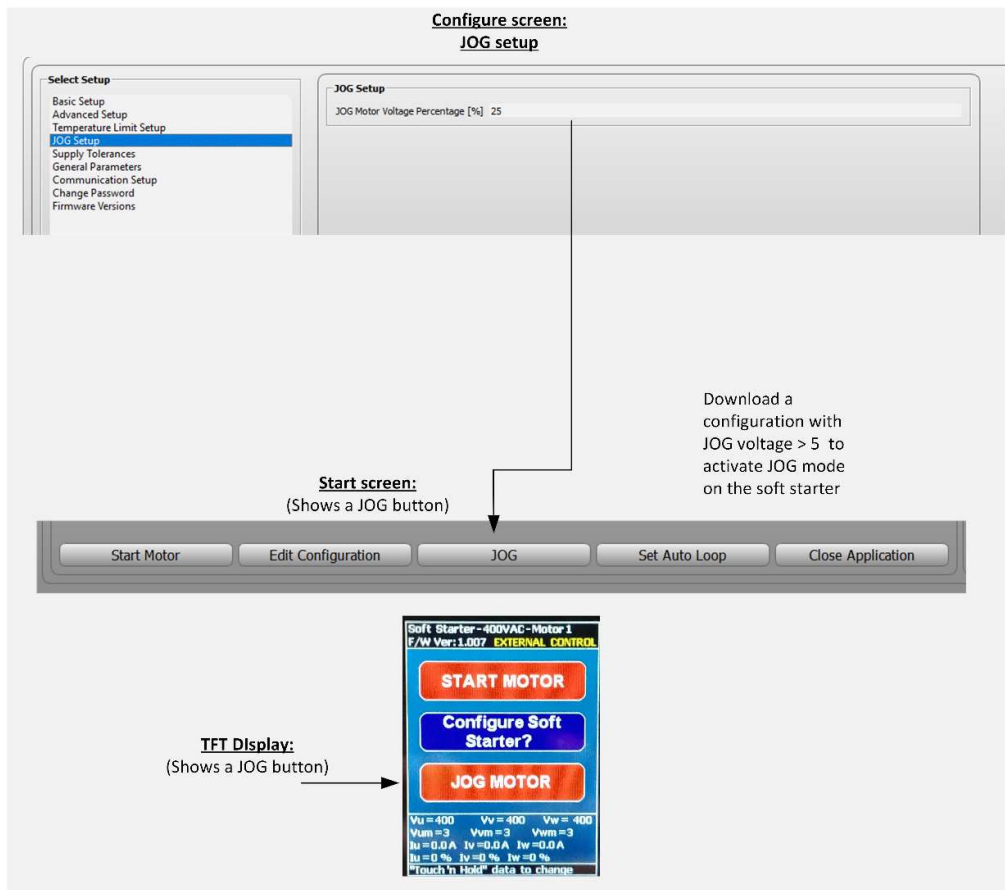

Figure 57 –Configure screen – JOG mode

7.1.7 Change the password and view the firmware revisions

On the Pro variant:

If required, a password can be set to protect against accidental or unauthorised changing of the configuration. Note that when the password is set via the PC Application or on the TFT, it will be required for each configuration change. If the password is lost, the distributor will have to be contacted to recover the functionality.

On the Core and the Pro variants:

The embedded firmware revisions can be viewed via the PC Application. Refer Figure 58

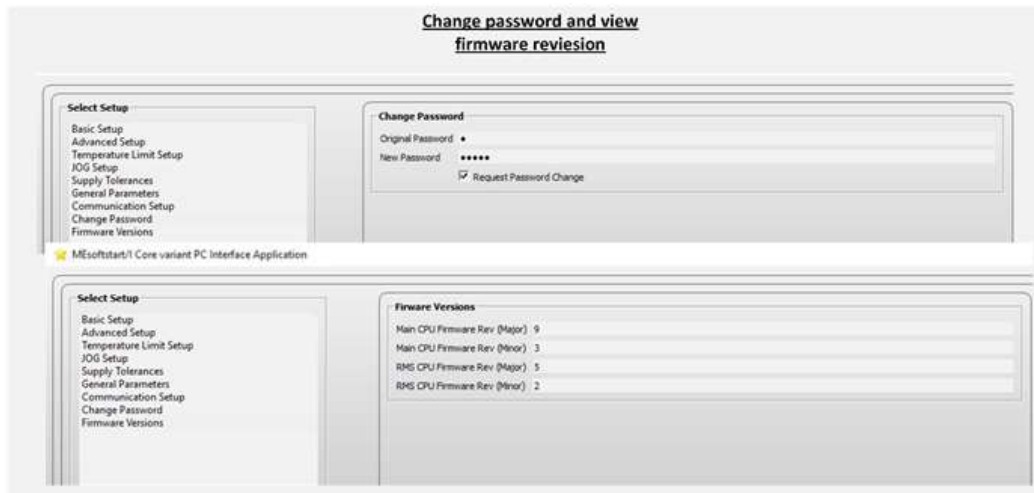

Figure 58 –Configure screen –password and revisions

7.1.8 Controlling the soft starter using the MEsoftstart PC App

On the Core variant – refer paragraph 5.3.2

On the Core and the Pro variants:

The MEsoftstart PC App may be used to control the soft starter. From the Start screen, use the “START” button to start the motor. View the progress of the start-ramp on the Start screen or the TFT display. Press the ‘Stop’ button and watch the stop ramp (if configured) and the implementation of the delay before start is again allowed.

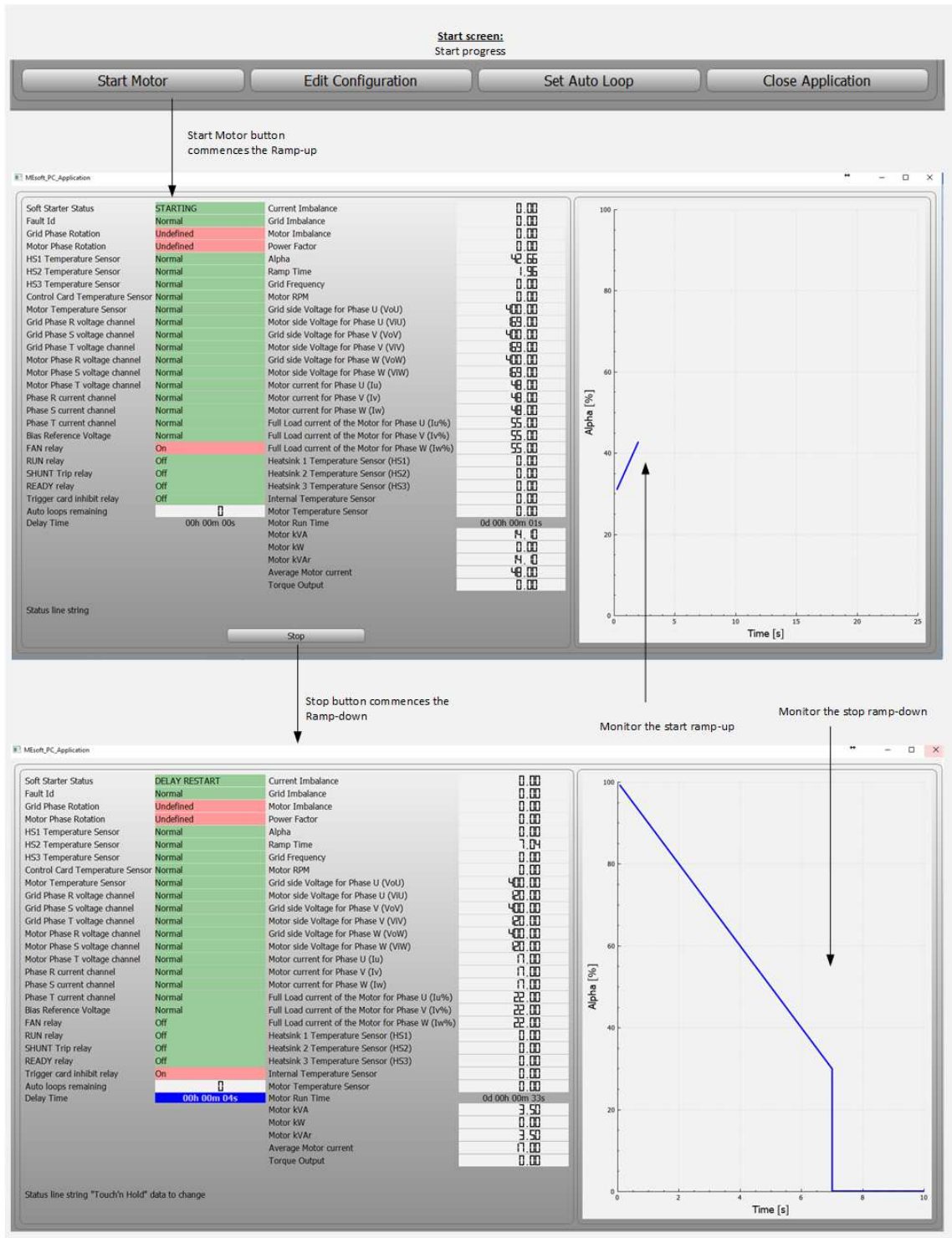

Figure 59 – MEsoftstart PC Application Control screen

7.1.9 Resetting the soft starter using the MEsoftstart PC Application

On the Core variant – refer paragraph 5.3.2

On the Core and the Pro variants:

Whenever a fault is detected by the soft starter, the soft starter will require a RESET before operation is possible again. Investigate the cause of the fault, fix the issue and “Reset” the soft starter using the button on the screen.

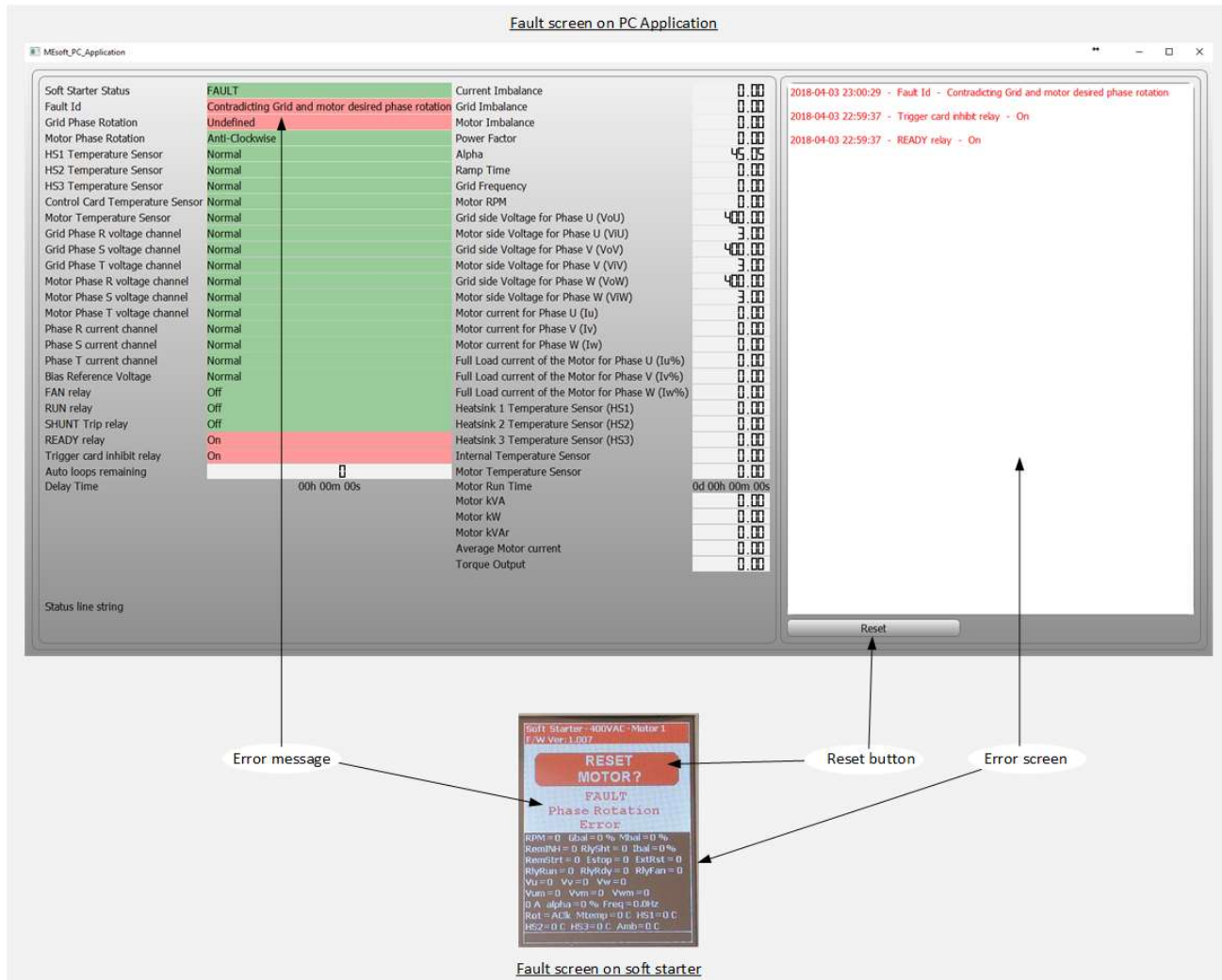

Figure 60 – MEsoftstart PC Application Fault screen

7.2 MEssoftstart Modbus interfaces

The MEssoftstart PC App and any SCADA system, both use the same MODBUS protocol and either is the Modbus Master when connected to the soft starter. The SCADA uses a subset of the total register definition. Some of the registers will only be used by the PC Application (*note: these register values will not be shown in the final SCADA SICD document*).

Note:

The MEssoftstart Core variant supports only Modbus RTU using RS485 using connectors J1 and J2.

The MEssoftstart Pro variant supports two Modbus interfaces:

- *Modbus RTU on RS485 using connectors J2 and J3*
- *Modbus TCP on Ethernet using connector J1 (Pro variants only)*

Please request the Modbus Software Interface Control Document from your local distributor.

The following general guidelines apply:

- The PC Application and the SCADA system may not be simultaneously present on the Modbus RTU RS-485 data bus due to bus conflict issues. Two Modbus devices may be present – one on the Modbus TCP port and one on the Modbus RTU port. The device that connects first, will be the Master and will be in control of the soft starter. The Master will be able to start, stop and reset the soft starter. The other Modbus device will only be able to monitor the status and progress sent by the soft starter.
- The Modbus Master can connect to the soft starter (via MODBUS messages) when the soft starter is in any state (Stopped, Starting, Stopping or Running) and request status updates as well as read the soft starter's present configuration.
- The soft starter configuration may only be updated by the Modbus Master when the soft starter is in the Stopped state. On receipt of a new configuration, the soft starter checks the password and then performs a validity check on the received parameters and responds either with errors, or with a positive response. A single configuration parameter compliance failure, will result in the whole configuration will be discarded (refer paragraph 6.5).
- The Modbus Master may send regular status request messages beginning when the soft starter is in Stopped mode. The Modbus Master will then be in control of the soft starter and will remain in control, provided that a continuous regular message is sent from the Master to the Soft starter. While the Modbus Master is in control of the soft starter the TFT display will indicate this with the words "TCPCTL" or "RTUCTL", depending on if the TCP Modbus master is in control, or the RTU Modbus master.
- If a second Modbus device is also present and monitoring, the TFT display will indicate "TCP" or "RTU" next to the control indication – refer Figure 39.
- If the soft starter does not receive messages from the Modbus Master for a period longer than 10 seconds, control will revert to the other Modbus device present or to the soft starter TFT display if no other Modbus device is present. The Modbus Master is required to ensure that it gets regular status updates from the soft starter at a recommended rate of once per second to keep itself apprised of the most up-to-date status of the soft starter.
- The soft starter is not able to distinguish when under Modbus control, whether it is the PC Application or a SCADA control system that is the Modbus Master.
- The soft starter Modbus interface does not support Modbus Broadcast mode or Silent mode.
- The RS-485 RTU Modbus communication interface is default set to 115200 BAUD, 1 Start, 1 Stop, and Even Parity (with the possibility of No Parity and Odd Parity available). This is reconfigurable from the Modbus Master and from the TFT display.

At present the following Modbus function codes (FCs) are supported:

- 4 = Read Input Register. (Read Only Registers)
- 3 = Read Holding Registers. (Read/Write Registers)
- 6 = Write Single Holding Register.
- 16 = Write Multiple Holding Registers.

The soft starter RTU address can be configured from 1 to 247.

Any write action either to Configuration registers, or the Control Command register, that receives a positive response back from the soft starter, may be interpreted by the Modbus Master as confirmation that the configuration data is correct and will be saved in the soft starter, or that the command will be put into effect. An error response must be interpreted as the opposite.

Updates to individual configuration parameters should be done by sending the full complement of configuration parameters.

8. PROTECTIVE FUNCTIONS & TROUBLESHOOTING (PRO)

This chapter explains the protection functions that are implemented in the PRO variants of the soft starter. For troubleshooting on the Core variant refer to paragraph 5.4.

⚠ This chapter explains the operation and use of this product. Always read the instructions before using the equipment.

8.	PROTECTIVE FUNCTIONS & TROUBLESHOOTING (PRO)	100
8.1	SOFT STARTER FAULT AND ALARM INDICATIONS	100
8.2	HOW TO RESET THE SOFT STARTER AFTER A FAULT HAS OCCURRED.....	101
8.3	TROUBLESHOOTING USING THE FAULT DISPLAY ON THE SOFT STARTER	102
8.4	GENERAL TROUBLESHOOTING	105

8.1 Soft starter fault and alarm indications

When the soft starter detects a fault, the operation panel displays a fault message, or a protective function activates to trip the soft starter - depending on the nature of the fault.

8.2 How to reset the soft starter after a fault has occurred

 *Always investigate to find the cause of the problem when a fault was detected by the soft starter. Do not just reset the system without understanding and fixing the cause of the reset.*

If the soft starter is not under external control of the Modbus controller or PC application:

On the Fault screen, press the RESET button to reset the fault on the soft starter or,

If the soft starter is under external control of the Modbus controller or the PC application (refer Figure 60):

Use the button on the PC application (or the Modbus command) to reset the soft starter.

If the soft starter is configured for Remote operation, the remote reset may be used to reset the soft starter:

Activate the remote reset signal the external RESET button.

Figure 61 shows an example of a fault screen with RESET button. The fault message and the parameters that are displayed may be used to understand the reason for the fault. Note that the fault screen in Figure 61 has a fault message that indicates that there is a Phase Rotation Error.

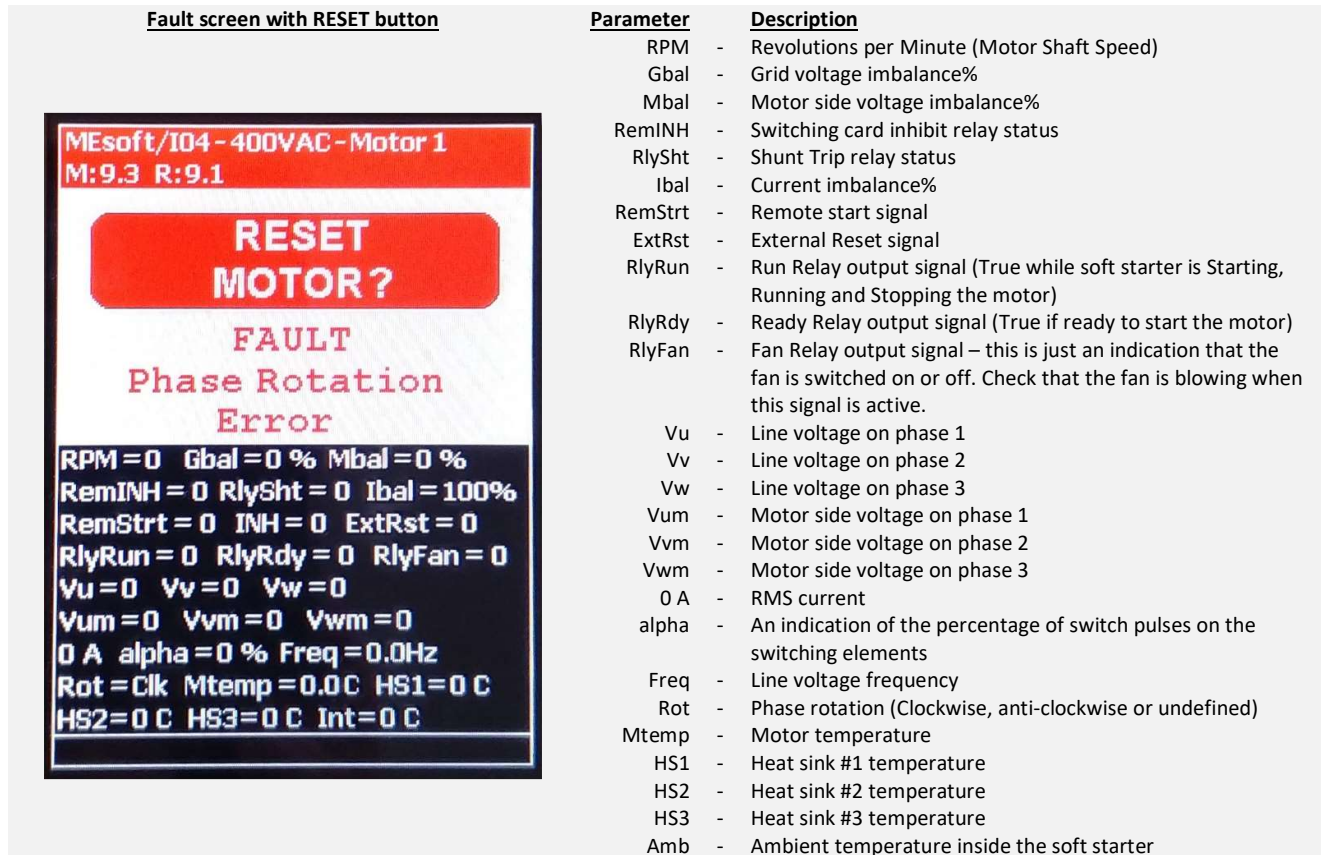

Figure 61 – MEsoftstart/I Pro TFT display Fault screen

8.3 Troubleshooting using the fault display on the soft starter

If the displayed message does not correspond to any of the following or if you have any other problem, please contact your sales representative.

The possible fault messages that the soft starter may display, are listed in the table below together with a detailed description of the fault and corrective actions.

If you need assistance with troubleshooting, it will be helpful if you can attach a photo of the screen with the fault message.

	Fault Message	Description	Corrective action
1.	Motor Protection Curve Trip Applicable during STARTING and RUNNING.	This trip may occur during Starting or Running and is time related to the protection curves, depending on which curve and by what proportion of the Motor Full Load Current, the motor is drawing.	If the motor allows, select a more lenient trip curve (Protection Class). (Refer paragraph 6.4.1).
2.	Start Overcurrent Applicable during STARTING.	An over current was detected during start-up. This trip occurs when the “Maximum Starting Current” is exceeded during the start ramp. This limit is defined by parameter “Overload .protection class” as described in paragraph 6.4.1.	Check the motor current specification and confirm that the “Maximum Starting Current” (refer 6.4.4) is set to an appropriate value in relation to the “Ramp-up time” (refer 6.4.1). Also confirm that the “Maximum Ramp-up time” is at least twice the length of the time set for “Ramp-up time”.

	Fault Message	Description	Corrective action
3.	Motor Overload Applicable during RUNNING.	An overload current was detected while the motor is running. This limit is defined by parameter "Motor Over Load Current" (MOLC) as described in paragraph 6.4.4.	Check the motor current specification and confirm that the configuration of the following parameters is correct: <ul style="list-style-type: none"> • Maximum Starting current • Motor Over load current
4.	Motor Underload Applicable during RUNNING.	An underload current was detected during the start-up ramp. This limit is defined by parameter "Motor Under Load Current" (MULC) as described in paragraph 6.4.4. The check is intended to protect the motor of e.g. a pump running dry.	Check the motor and the motor load to ensure all is in order. Check the motor current specification and confirm that the configuration of the following parameter is correct: <ul style="list-style-type: none"> • Motor Under load current
5.	Voltage Unbalance	A voltage unbalance was detected between the phases of the supply voltage. This limit is defined by parameter "Voltage unbalance" as described in paragraph 6.4.7. This may be caused by one of the three supply phases that are not present or a wiring error or grid supply not being within specification. Supply voltage unbalance can result in a failure to start or a noisy rough start.	Monitor the supply voltage to confirm that all three phases are present and phases are within the local grid specification. Adjust the voltage unbalance limit that the soft starter will tolerate.
6.	SCR Volt Unbalance	This fault is detected as part of a self-test during a soft starter power-up (before the soft starter is in IDLE mode ready to start the motor). It is an indication of a failure in the SCR hardware.	Please contact your local distributor.
7.	Motor Over Temperature	A high temperature on the motor caused the soft starter to trip in order to protect the motor. This limit is defined by parameter "Motor Maximum Temperature" as described in paragraph 6.4.5. This error will auto-correct once the motor temperature drops below the configured "Motor re-start temperature" Refer paragraph 6.4.5.	Inspect the motor and the load. High motor temperature may be caused by a too heavy load, or by a malfunction on the motor such as a locked rotor. High temperature can also be caused by a long starting ramp (refer paragraph 6.4.1). Fix problems on the motor or load If this is not the cause of the problem, select a shorter starting ramp with possibly a higher starting current (refer paragraph 6.4.4).
8.	Over Voltage	These errors are related to the supply voltage and frequency being outside the specification for the soft starter.	Monitor the supply voltage and frequency Confirm that the voltage and frequency is within the specification for the model of soft starter that is installed. Check the label on the soft starter to confirm that the supply voltage is within the rating of the soft starter.
9.	Under Voltage		
10.	Frequency Limits exceeded		
11.	Internal Temp High	This message indicates that the measured temperature inside the soft starter enclosure is too high. Damage will occur if operation is continued.	Check to confirm that the fans are working. Note that the soft starter may be configured to start the fans always when the motor is running, or to start the fans only when the temperature is rising. (Refer paragraph 6.4.5). Confirm that air inlets and outlets on the soft starter and on the motor control enclosure is not blocked. Refer paragraph 2.3.3.
12.	Heatsink Temp High	This message indicates that the measured temperature on the heatsinks inside the soft starter is too high. Damage will occur if operation is continued.	Check fans and air flow as above for the ambient temperature. Confirm that the configuration regarding the bypass contactor is correct (refer paragraph 6.4.1).

	Fault Message	Description	Corrective action
		<p>The heatsinks will get too hot if the number of starts per hour is very high, or if the soft starter is used to run the motor for a long time without a bypass contactor.</p> <p>The correct operation of the fans is very important to control the heatsink temperatures.</p> <p>This error will auto correct when the temperature drops below the "Heatsink restart temperature" as configured (refer paragraph 6.4.5).</p>	<ul style="list-style-type: none"> If an external bypass contactor is used, confirm that the bypass contactor is working and that the control and supply wiring is correct. (paragraph 6.4.5). <p>Reduce the number of starts per hour Reduce the start-up ramp time.</p>
13.	Motor Short Circuit Phase U, W, V	The soft starter detects a short circuit on the motor-side terminals during pre-startup tests.	<p>Check the motor for failure or loose wires.</p> <p>Check the wiring between the soft starter and the motor.</p> <p>Check the wiring of the bypass contactor. If using an inside-delta installation, check the wiring on the six-wire motor connection.</p>
14.	SCR Fault (OC or SC) SC – Short Circuit OC – Open Circuit	This fault is an indication of a failure in the SCR hardware.	Please contact your local distributor.
15.	Current Imbalance Applicable during RUNNING.	<p>A current unbalance was detected between the phases of the supply lines. This limit is defined by parameter "Current unbalance" as described in paragraph 6.4.7.</p> <p>This may be caused by one of the three supply phases that is not present or a wiring error or grid supply not being within specification or a faulty motor.</p> <p>Current unbalance can result in a failure to start or a noisy rough start.</p>	<p>Check the motor for any faults.</p> <p>Monitor the supply voltage to confirm that all three phases are present and phases are within the local grid specification.</p> <p>Adjust the current unbalance limit that the soft starter will tolerate.</p>
16.	Remote control from wired buttons or Modbus controller is not working	The system may be in 'Maintenance' so that ONLY control from the local HMI panel is allowed.	Ensure that the Auto/Maintenance switch is on Auto to allow for any remote control. Refer par. 6.8
17.	Maintenance was activated	This is just an information message that the Maintenance input is active. The condition should resolve itself when the Maintenance signal is removed.	<p>If the message persists, check the Auto/Maintenance signal wiring (refer Table 14).</p> <p>Remember that the Auto/Maintenance switch should provide a normally closed signal that is opened to activate Maintenance mode.</p>
18.	Maximum Start Time exceeded	The motor did not start within the maximum starting time that is configured by the parameter "Maximum Ramp-up Time" Refer par 6.4.2. This may be because the allowed starting time is too short or because the starting current that was configured in "Maximum Starting Current" is too low (refer paragraph 6.4.4).	<p>Confirm that the starting current is sufficient to start the motor in the time allowed.</p> <p>Adjust the parameters as required.</p>
19.	Max Frame Current exceeded	This fault could be due to a short circuit or overly aggressive start-up configuration. If the motor current exceeds the stack maximum capabilities, this trip will occur.	<p>Check the start-up configuration – reduce the "Maximum Starting Current" (refer paragraph 6.4.4).</p> <p>Check to confirm that the soft starter model is the correct model for the application. Refer paragraph 1.1.1.</p>
20.	Motor RPM exceeded	This error is an indication that the motor speed was exceeded. This fault is only applicable when the shaft sensor is present.	<p>Check the shaft sensor installation and wiring.</p> <p>Confirm that the Maximum Starting Current.</p>
21.	Phase Rotation Error	The phase rotation that is configured, is not the same as the actual phase rotation that the soft starter detects on the supply lines.	Check that the wired phase rotation is correct and set the "Phase Rotation" parameter accordingly.

	Fault Message	Description	Corrective action
		The phase rotation is configured by parameter "Phase Rotation" refer paragraph 6.4.1). If the phase rotation is not corrected, the motor will rotate in the wrong direction.	If motor rotation direction is not important, this parameter may be set to "Don't care"
22.	Sensor Failure	This message is displayed if an internal sensor failure is detected. It will be followed by a line giving an indication of which sensor failed.	

8.4 General Troubleshooting

8.4.1 Soft starter display does not power up

Description	Corrective action
The soft starter display does not start up when power is applied to the soft starter.	<p>Remove external communication cables from the RJ 45 RS485 and TCP connectors if present.</p> <p>Switch off the circuit breaker.</p> <p>Check the wiring.</p> <p>Disconnect the motor side terminals.</p> <p>Switch on the circuit breaker.</p> <p>Measure on the soft starter L1, L2, L3 terminals that all three phases are present and within expected limits.</p> <p>If the display is still not starting up with the supply voltage confirmed present and correct on the grid-side terminals of the soft starter while not connected on the motor side: Please contact your local distributor.</p>

8.4.2 Motor generates abnormal heat

Description	Corrective action
The motor temperature is higher than expected.	<p>Check the motor rating plate for supply voltage specification.</p> <p>Inspect the motor rotation, wiring, fan and environment.</p> <p>Check that the load is appropriate for the motor.</p> <p>Measure for imbalance on voltage and current.</p> <p>Reduce the start ramp-up time (a slow ramp may cause more heat build-up than a faster ramp).</p>

8.4.3 Soft starter generates abnormal noise

Description	Corrective action
A strange sound coming from the soft starter	<p>Check the fan blades for any interference.</p> <p>If the fan was recently replaced, ensure that the fan cover is replaced correctly, e-g- fan is not rubbing against the cover.</p>

8.4.1 Modbus controller cannot connect

Description	Corrective action
The MSoftstart PC Application or another Modbus controller is unable to connect to the soft starter	<p>Check the TFT display – after power-up the configuration needs to be accepted on the TFT before it will connect to a Modbus Master.</p> <p>Check the cable – use the cable supplied.</p> <p>Check the communication parameters on the soft starter (refer paragraph 6.4.9). Ensure that the Modbus controller or PC Application has the same settings as the soft starter and is communicating to the correct RTU address.</p> <p>If using the PC application, check that the driver for the USB converter is installed. (Refer paragraph 7.1.1).</p>

9. MAINTENANCE AND INSPECTION

This chapter explains the precautions for maintenance and inspection for this product.

9. MAINTENANCE AND INSPECTION.....	106
9.1 INSPECTION ITEM	107

9.1 Inspection item

The soft starter is a static unit mainly consisting of semiconductor devices. Weekly inspection should be performed to prevent any fault from occurring due to the adverse effects of the operating environment, such as temperature, humidity, dust, dirt and vibration, changes in the parts with time, service life and other factors.

- ⚠ When accessing the soft starter for inspection, wait for at least 10 minutes after the power supply has been switched OFF before touching the soft starter.

9.1.1 Weekly inspection

Check the following during operation:

- Motor operation alarm.
- Improper installation environment.
- Cooling system fault.
- Abnormal vibration, abnormal noise, bearing noises in motor.
- Abnormal overheat and discoloration of terminals.
- Protective covers on terminals

9.1.2 Periodic inspection

Check the following when the unit is not operational:

- Check that there is no voltage on the input terminals.
- Check all areas inaccessible during operation.
- Clean the air inlet and outlet grills.
- Torque screws and bolts as they may become loose due to vibration and temperature variations.
- Check connections and insulating materials for corrosion and damage.
- Measure the insulation resistance and confirm that this is still within limits for the installation.
- Check and replace the cooling fan/s every 5 operating years or as required.



9.1.3 Weekly and periodic inspection checklist

Area of inspection	Inspection item	Description	Inspection interval		Corrective action at fault occurrence	Check
			Weekly	Periodic ⁵		
General	Surrounding environment	Check the surrounding air temperature, humidity, dirt, corrosive gas, water, oil, etc.	☑		Improve the environment.	
	Overall unit	Check for unusual noise and vibration.	☑		Check fault location and re-torque.	
		Check for dirt, oil and other foreign material.	☑		Clean.	
Power supply voltage	Check that the main circuit voltages and control voltages are within the operating range ⁶ .	☑		Inspect the power supply.		
Main circuit	General	Check for loose screws and bolts.		☑	Retighten.	
		Check for overheat traces on the parts.		☑	Contact the manufacturer.	
		Check for stain.		☑	Clean.	
	Conductors, cables	Check conductors for distortion.		☑	Contact the manufacturer.	
		Check cable sheaths for breakage and deterioration (crack, discoloration, etc.).		☑	Contact the manufacturer.	
	Terminal block	Check for damage.		☑	Stop the equipment and contact the manufacturer.	
Relay/contactors	Check that the operation is normal and no chattering sound is heard.		☑	Contact the manufacturer.		
Control circuit	Operation check	Check that the output voltages across phases are balanced while operating the soft starter.		☑	Contact the manufacturer.	
		Check that no fault is found in protection and display circuits during operation.		☑	Contact the manufacturer.	
	Protective circuit	Overall	Check for unusual odor and discoloration. Check for serious rust development.		☑ ☑	Stop the equipment and contact the manufacturer. Contact the manufacturer.
Cooling system	Cooling fan	Check for unusual vibration and noise. Check for loose screws and bolts. Check for dust and stain.	☑	☑ ☑	Replace the fan. Retighten the fan fixing screws. Clean.	
Safety	Protective covers	Check that the covers are in place covering the Grid side and Motor side terminals.	☑		Fit the protective covers over the terminals.	

9.1.4 Cleaning

Always run the soft starter in a clean condition.

When cleaning the soft starter, gently wipe dirty areas with a soft cloth dampened with neutral detergent or ethanol.

-  Do not use solvent, such as acetone, benzene, toluene or alcohol, as these might damage the soft starter surface.
-  The display is vulnerable to detergent and alcohol. Only use a soft cloth dampened with water.

⁵ One to two years of periodic inspection cycle is recommended. However, it differs according to the installation environment.

⁶ It is recommended to install a voltage recording device for monitoring the voltage of the power supplied to the soft starter.

9.1.5 Replacement of parts

The soft starter consists of many electronic parts and power semiconductor devices. The only parts that may be replaced on the installation site, are the fans on the MEsoftstart/I01 Core and all Pro variants.

Part name	Estimated lifespan	Description
Cooling fan, part number to be supplied	5 Operational years but greatly affected by the operational environment such as dust and humidity.	Replace (as required). Refer Advanced Maintenance.

-  Before starting the fan replacement, switch power OFF, wait for at least 10 minutes and then check the voltage with a Multi-Meter or voltage tester to ensure safety.

10. SPECIFICATIONS

This chapter explains the specifications of this product. Always read the instructions before using the equipment.

10.	SPECIFICATIONS	110
10.1	SOFT STARTER SPECIFICATION	111
10.2	OUTLINE DIMENSION DRAWINGS	112

10.1 Soft starter specification

Parameter	Specification				
Supply Voltage	340 – 420Vac, 425 – 578Vac, 586 -760Vac				
Current Ratings	MEsoftstart/I00	MEsoftstart/I01	MEsoftstart/I02	MEsoftstart/I03	MEsoftstart/I04
• Max. continuous current @ +50°C	100A	200A	390A	600A	900A
• Mitsubishi Electric Bypass contactor	S-T80	S-N150	S-N400	S-N600	(S-N800)
• Max continuous current with bypass	120A	200A	450A	800A	1000A
• Max. starting current – normal duty	240A	480A	730A	1440A	1600A
• Max. starting current – heavy duty	125A	250A	390A	750A	900A
Operating temperature	-10°C - +60°C. De-rate all Ampere values at 1.4% per °C for temperatures >50°C				
Storage temperature	-30°C - +70°C				
Relative humidity	< 85%				
Operating altitude	1400m above sea-level (no derating). De-rate at 0.7% per 100m for altitudes >1400m				
Enclosure protection category	IP00				
Communication	<ul style="list-style-type: none"> Standard on all variants Pro variants only 				
	Core-variants		Pro variants		
Digital IO	3 relay outputs (5A, 240Vac, pot. free): READY, BYPASS, FAULT		8 relay outputs included (5A, 240Vac, pot. free): READY; RUNNING; TRIP; BYPASS CONTACTOR; OVERLOAD ALARM; FAULT / LINE VOLTAGE ALARM; TEMPERATURE FAULT		
	3 inputs included: RUN/STOP, RESET, Auto/Maintenance		3 inputs included: RUN/STOP; Auto/Maintenance; RESET.		
Temperature Measurement inputs	PT-100 or LM35 motor temperature measurement channels (sensors purchasable separately)				
Fault indication	Displayed on the TFT touch screen on Pro variants / flashing LED sequences on Core variants				
Mounting	Chassis mounted (see dimensions)				
Module physical data (with finger guards)	MEsoftstart/I00	MEsoftstart/I01	MEsoftstart/I02	MEsoftstart/I03	MEsoftstart/I04
• Size WxHxD [mm] – no bypass	320x515x319	320x515x319	430x677x324	522x662x320	980x586x320
– with internal bypass	320x515x319	375x515x319	665x677x324	842x605x319	-
• Weight – no bypass	12kg	18kg	22kg	40kg	60kg
– with internal bypass	16kg	25kg	49kg	67kg	-
Approximate heat loss (without bypass at maximum rated current)	450W	650W	780W	1670W	3410W
Insulation resistance	Dielectric breakdown voltage: 2kV				
Current sensors					
Rated frequency range	45Hz - 65Hz				
Quantity	3 (Hall effect on MEsoftstart/I00 and /I01, CTs on models MEsoftstart/I02 through /I04)				
Measurement dynamic range	0% - 100% of soft starter maximum starting current – normal duty				
Thermal rating	Continuous: 2.5x rated current				
Accuracy	1.0% of full scale				
Sampling frequency	16.6kHz				
Voltage sensor					
Rated frequency range	45Hz - 65Hz				
Quantity	3 (direct sense by resistor bridge)				
Maximum rated voltage	760Vac				
Thermal rating	800Vrms				
Accuracy	1% of full scale				
Sampling frequency	16.6kHz				
CE mark compliance	Low voltage directive (2014/35/EU) EMC directive (2014/30/EU) RoHS 2 (2011/65/EU)				
Standards applied (relevant sections)	IEC/EN 60947-1 IEC/EN 60947-4-2				

*1 – Normal duty is for up to 10 starts per hour and start-up time no more than 30 seconds.

*2 – Heavy duty is for more than 10 starts per hour or start-up time longer than 30 seconds.

10.2 Outline dimension drawings

10.2.1 Msoftstart/I00 - 100A model

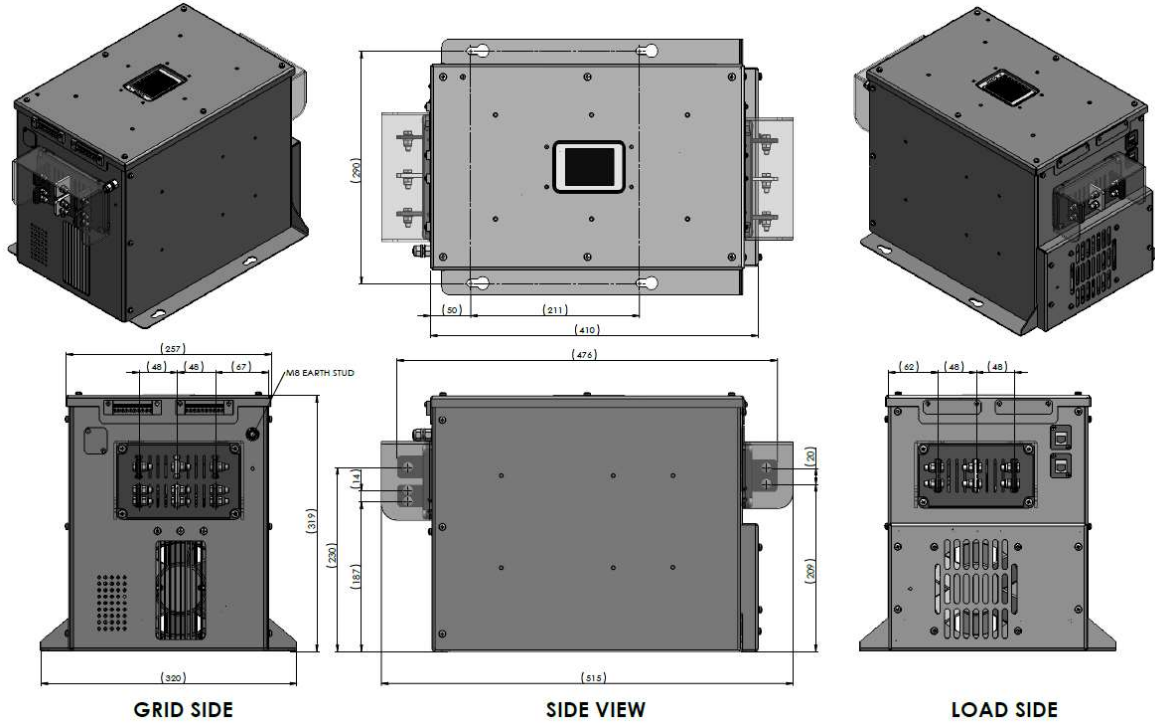

Figure 62: Msoftstart/I00 without internal bypass contactor

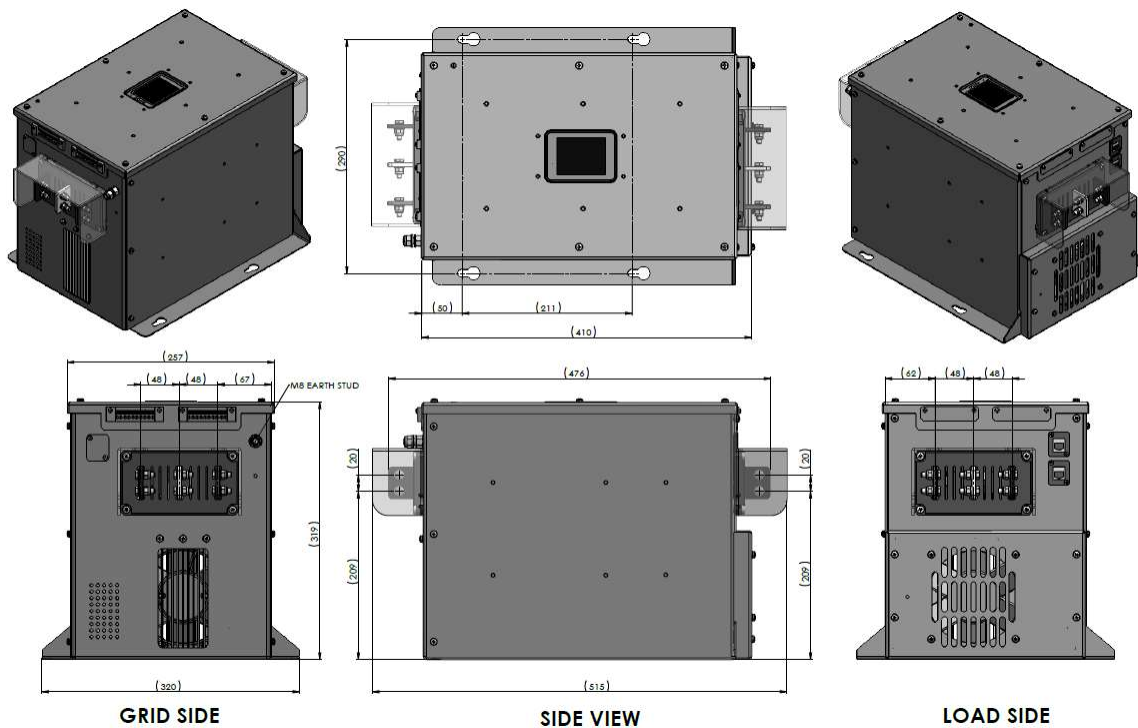

Figure 63: Msoftstart/I00 with internal bypass contactor

10.2.2 Msoftstart/I01 - 200A model

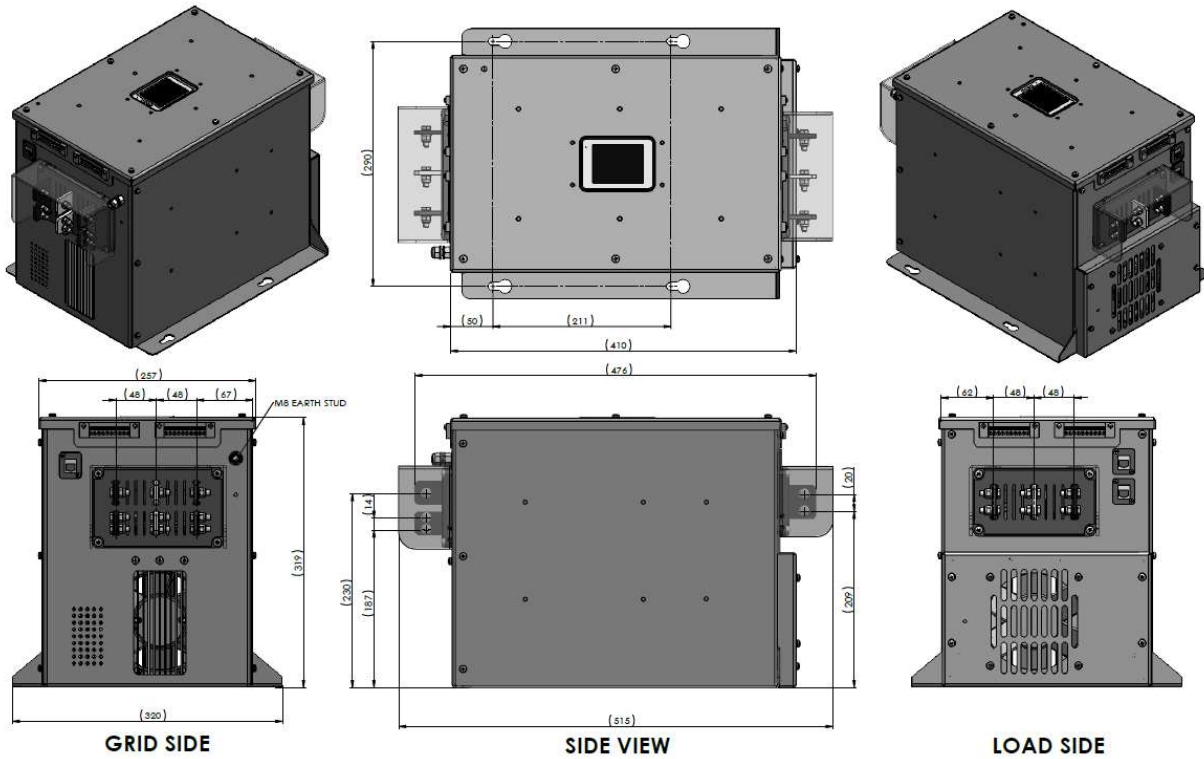

Figure 64: Msoftstart/I01 without bypass contactor

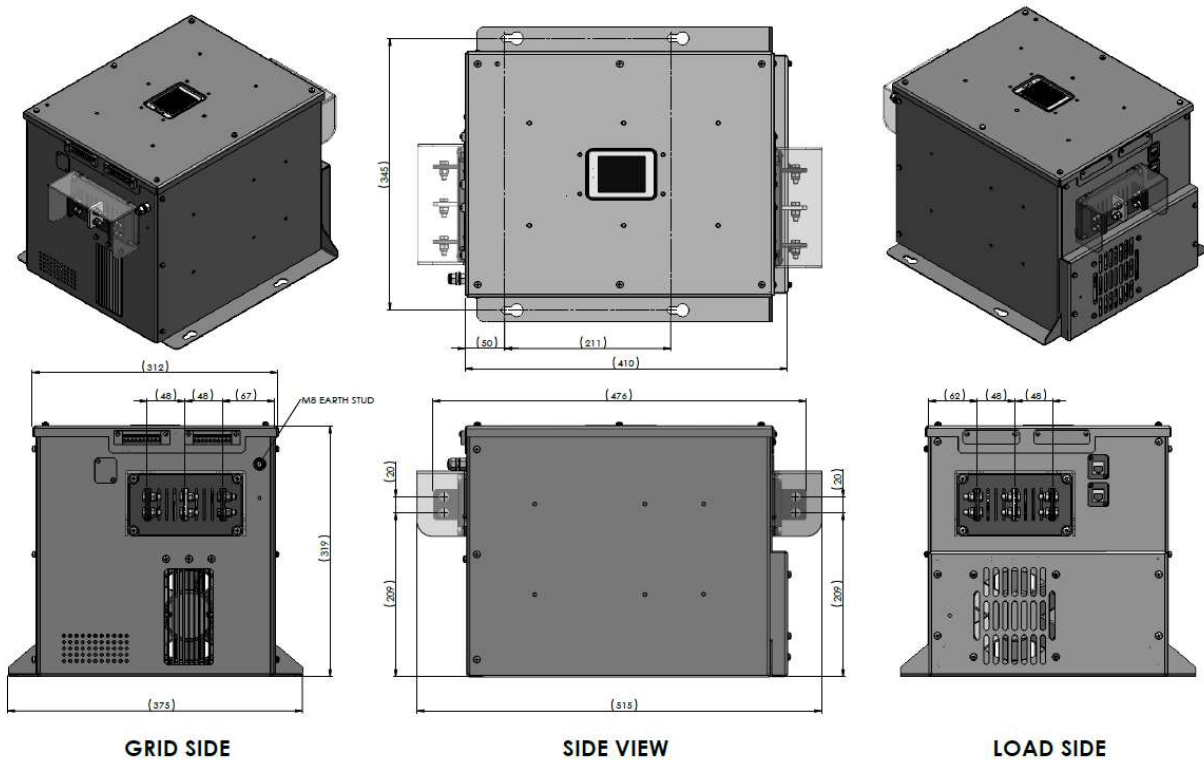

Figure 65: Msoftstart /I01 with internal bypass contactor

10.2.3 Msoftstart/I02 - 390A model

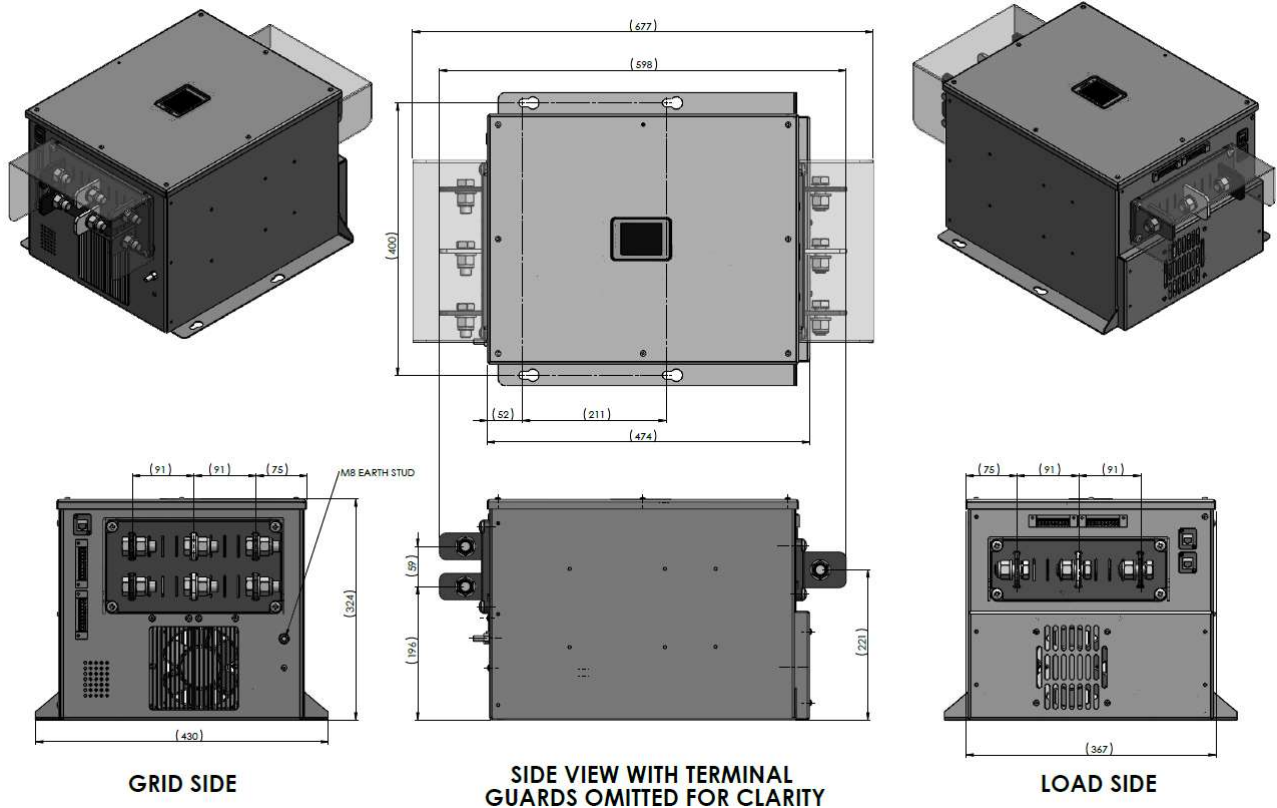

Figure 66: Msoftstart/I02 without bypass contactor

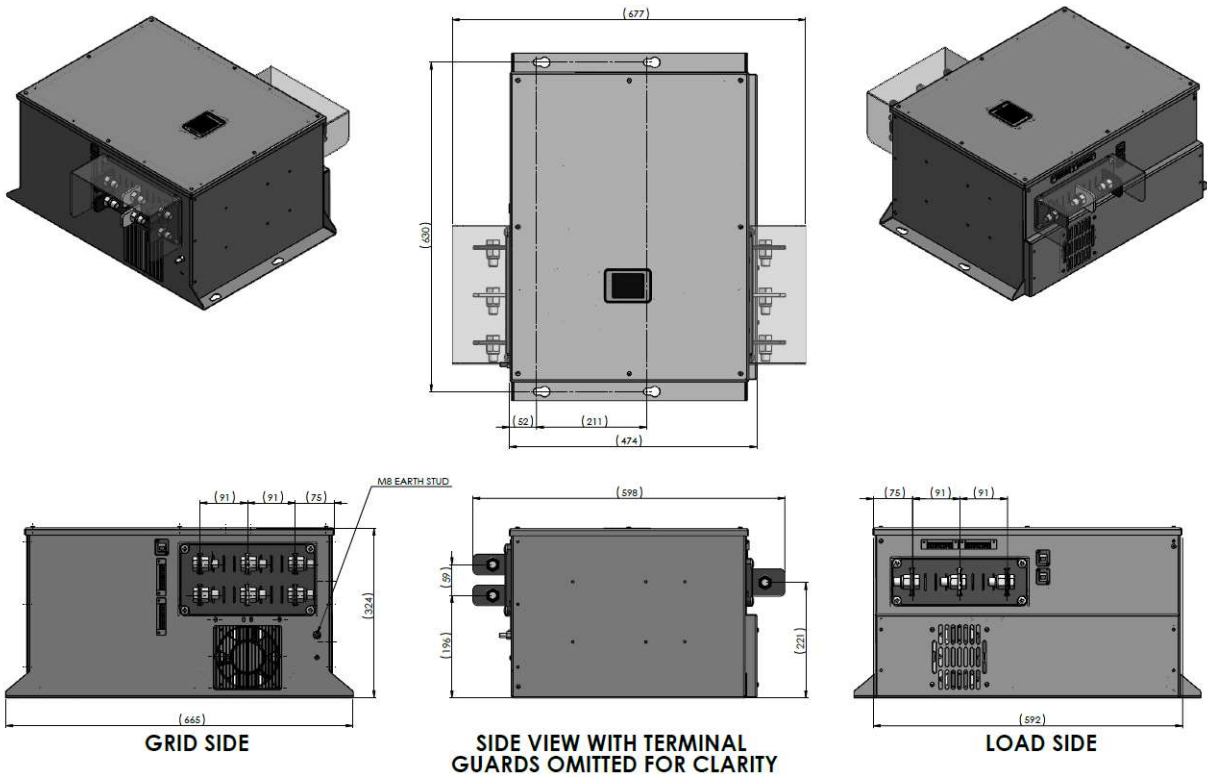

Figure 67: Msoftstart/I02 with internal bypass contactor

10.2.4 Msoftstart/I03 - 600A model

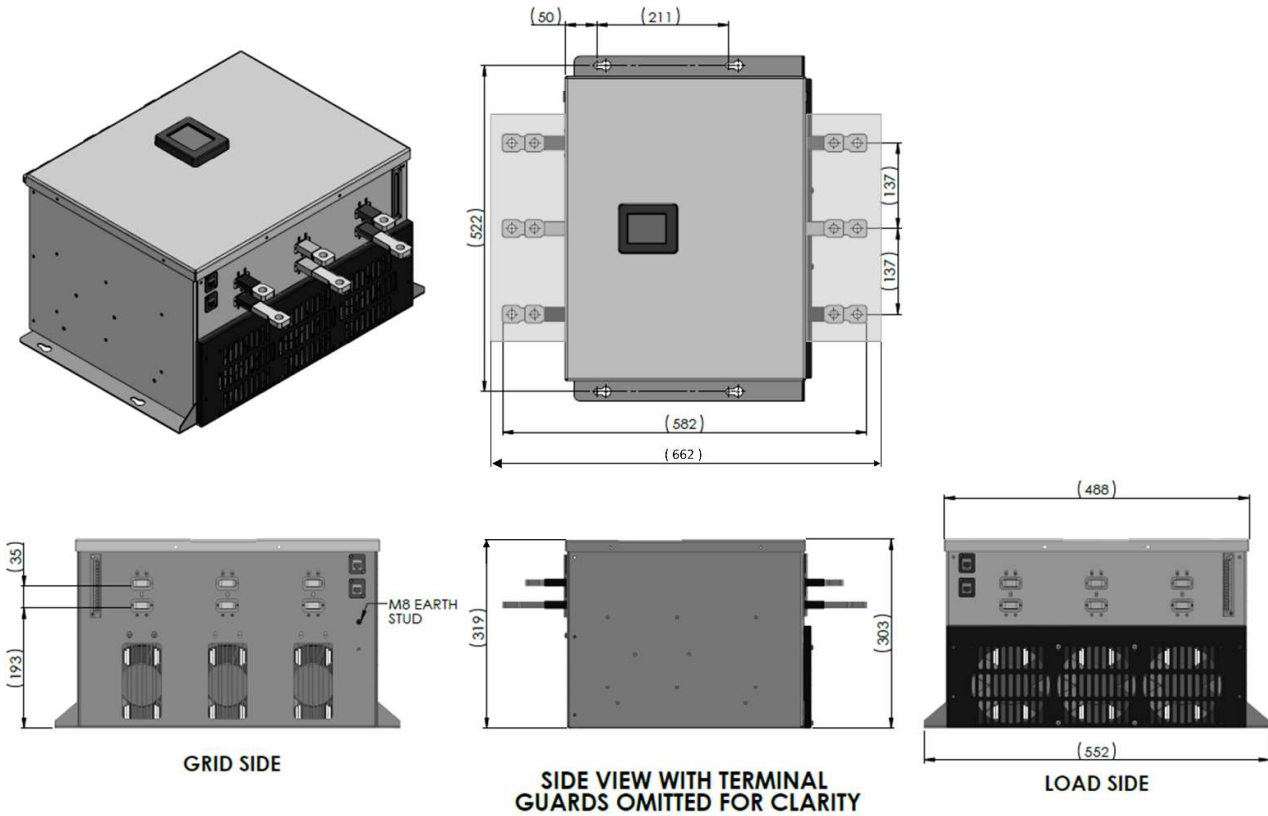

Figure 68: Msoftstart/I03 without bypass contactor

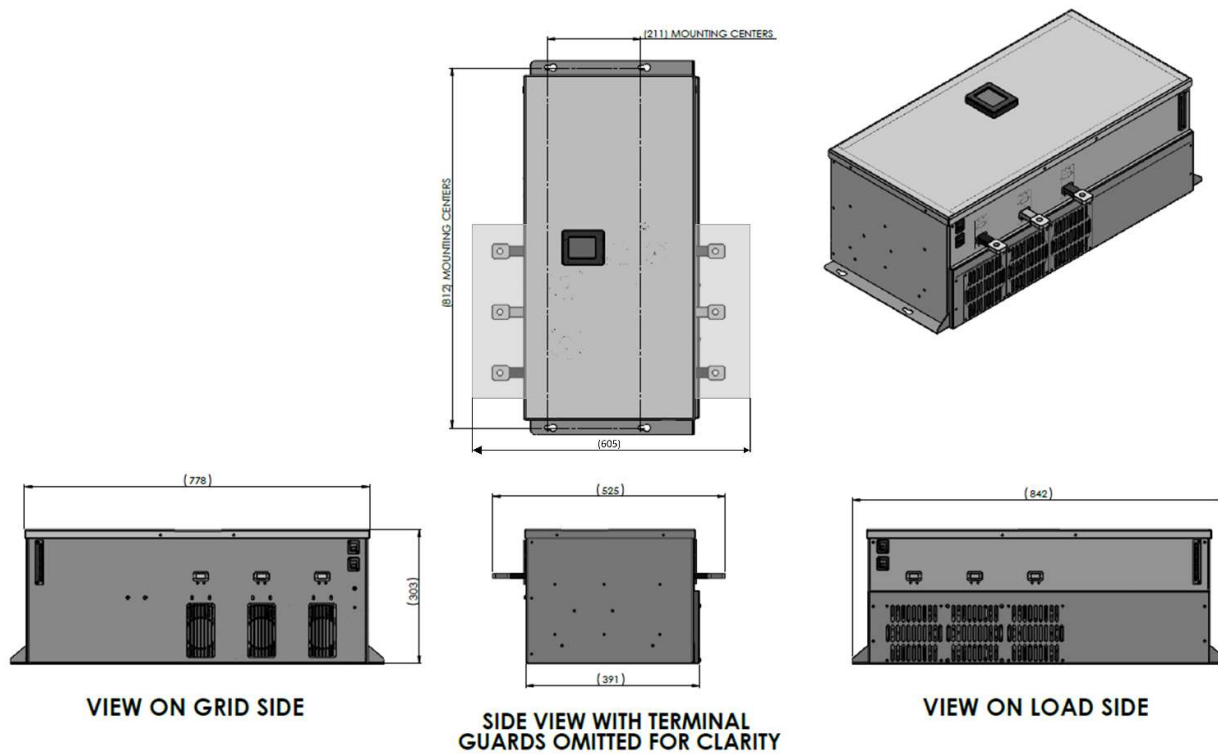

Figure 69: Msoftstart/I03 with internal bypass contactor

10.2.5 MSoftstart/I04 - 900A model

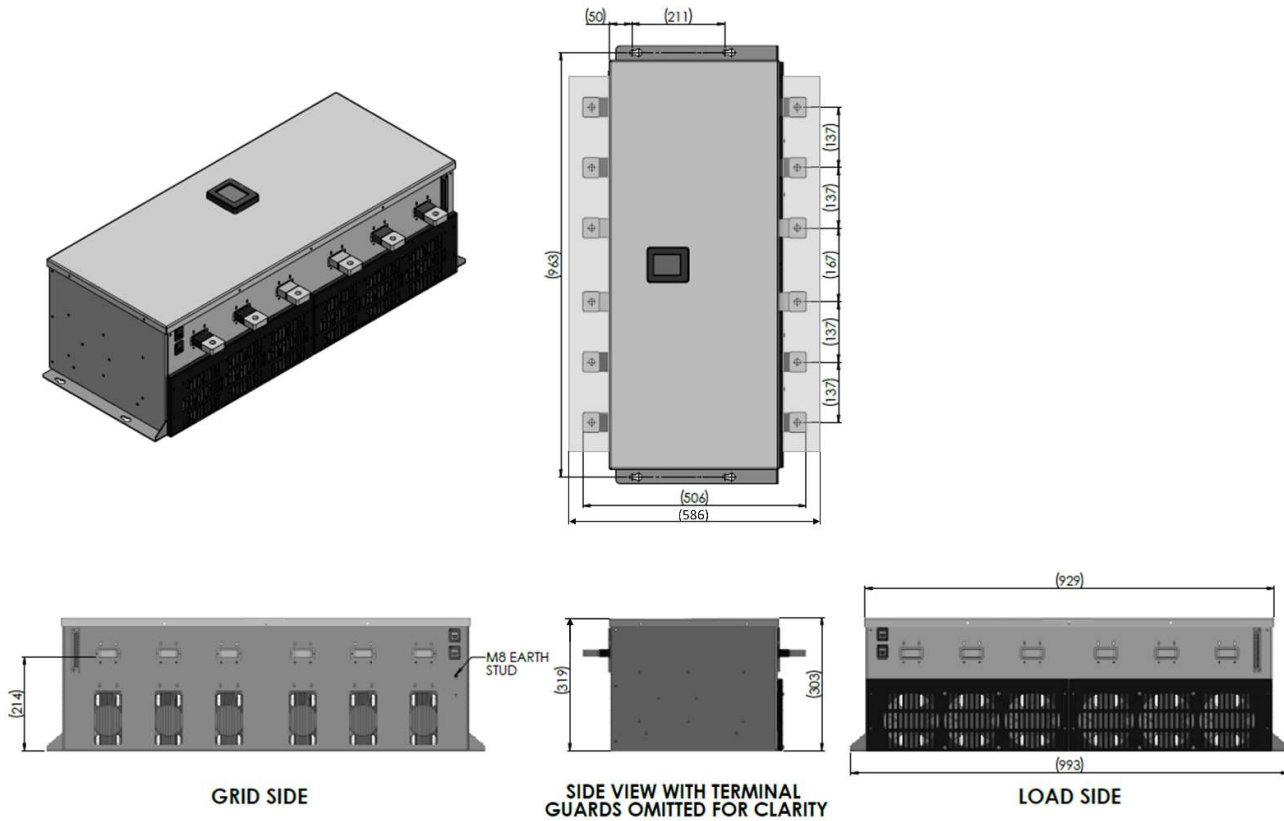

Figure 70: MSoftstart/I04 without bypass contactor

Note: No internal bypass contactor option is available for the MSoftstart/I04 model.

APPENDICES

This APPENDIX provides the additional maintenance information for this product.

APPENDIX	117
ADVANCED MAINTENANCE: REPLACEMENT OF THE FAN	118

Advanced Maintenance: Replacement of the fan

The soft starter should never be opened by the user, as this will void the installer's warranty. The installer may however need to open the soft starter to replace the fan (or fans on the MEsoftstart/I03 and MEsoftstart/I04). Instructions are provided in this section. Removing the bottom cover gives access to the fan. Pictures show the MEsoftstart/I01.

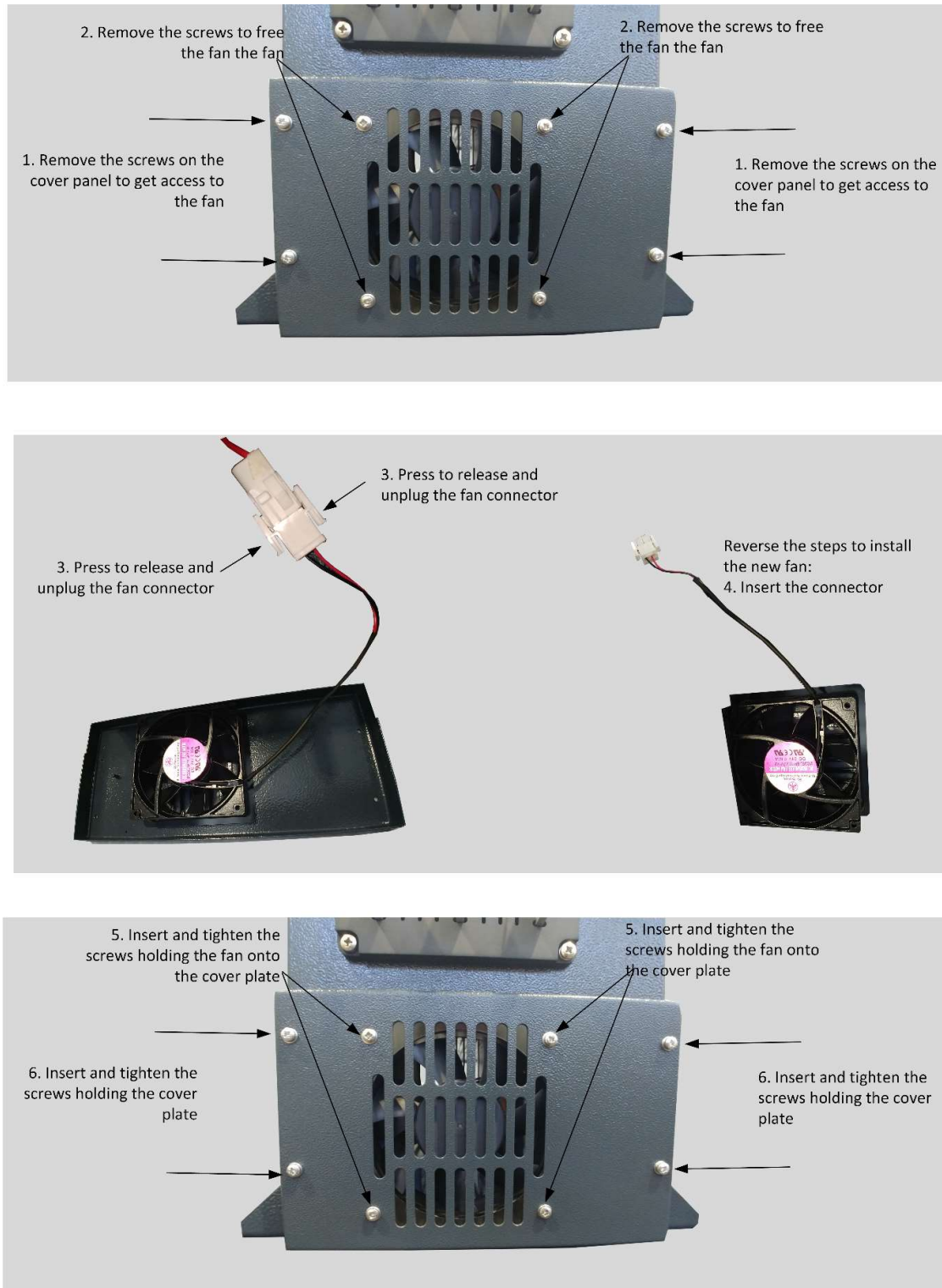

Figure 71: Replacement of the fan

European Offices

Germany Mitsubishi Electric Europe B.V. Mitsubishi-Electric-Platz 1, 40882 Ratingen Phone: +49 (0)2102 / 486 0	Czech Rep. Mitsubishi Electric Europe B.V. Radlická 751/113e Avenir Business Park CZ-158 00 Praha 5 Phone: +420 251 551 470	France Mitsubishi Electric Europe B.V. 25, Boulevard des Bouvets F-92741 Nanterre Cedex Phone: +33 (0)1 / 55 68 55 68	Italy Mitsubishi Electric Europe B.V. Viale Colleoni 7 Palazzo Siro I-20864 Agrate Brianza (MI) Phone: +39 039 / 60 53 1	Ireland Mitsubishi Electric Europe B.V. Westgate Business Park, Ballymount JRL-Dublin 24 Phone: +353 (0)1 4198800	Netherlands Mitsubishi Electric Europe B.V. Nijverheidsweg 23a NL-3641RP Mijdrecht Phone: +31 (0) 297250350	Poland Mitsubishi Electric Europe B.V. ul. Krakowska 50 PL-32-083 Balice Phone: +48 (0) 12 347 65 00
Russia Mitsubishi Electric (Russia) LLC RU-115054 Moscow Phone: +7 495 / 721 2070	Spain Mitsubishi Electric Europe B.V. Carretera de Rubí 76-80 Apdo. 420 E-08190 Sant Cugat del Vallés (Barcelona) Phone: +34 (0) 93 / 5653131	Sweden Mitsubishi Electric Europe B.V. (Scandinavia) Fjellövägen 8 SE-22736 Lund Phone: +46 (0) 8 625 10 00	Turkey Mitsubishi Electric Turkey Elektrik Ürünleri A.Ş. Şerifali Mahallesi Nutuk Sokak No:5 TR-34775 Ümraniye-İSTANBUL Phone: +90 (0)216 / 526 39 90	UK Mitsubishi Electric Europe B.V. Travellers Lane UK-Hatfield, Herts. AL10 8XB Phone: +44 (0)1707 / 28 87 80	UAE Mitsubishi Electric Europe B.V. Dubai Silicon Oasis United Arab Emirates - Dubai Phone: +971 4 3724716	

Representatives

Austria GEVA Wiener Straße 89 A-2500 Baden Phone: +43 (0)2252 / 85 55 20	Belarus OOO TECHNIKON Prospect Nezavisimosti 177-9 BY-220125 Minsk Phone: +375 (0)17 / 393 1177	Belgium ESCO DRIVES Culliganlaan 3 BE-1831 Dlegem Phone: +32 (0)2 / 717 64 60	Belgium KONING & HARTMAN B.V. Woluweaan 31 BE-1800 Vilvoorde Phone: +32 (0)2 / 257 02 40	Bosnia and Herzegovina INEA RBT d.o.o. Stegne 11 SI-1000 Ljubljana Phone: +386 (0)1 / 513 8116	Bulgaria AKHNATON 4, Andrei Ljapchev Blvd., PO Box 21 BG-1756 Sofia Phone: +359 (0)2 / 817 6000	Croatia INEA CR Losinjska 4 a HR-10000 Zagreb Phone: +385 (0)1 / 36 940 - 01 / -02 / -03
Czech Republic AutoCont C.S. S.R.O. Kařkova 1853/3 CZ-702 00 Ostrava 2 Phone: +420 595 691 150	Denmark HANS FØLSGAARD A/S Telljærkatu Torv 1 DK-4600 Køge Phone: +45 4320 8600	Finland PROVENDOR OY Telljærkatu 8 A3 FIN-28130 Porri Phone: +358 (0) 2 / 522 3300	Greece UTEKO A.B.E.E. 5, Mavrogenous Str. GR-18542 Piraeus Phone: +30 (0)211 / 1206-900	Hungary MELTRADE Kft. Fertő utca 14, HU-1107 Budapest Phone: +36 (0)1 / 431-9726	Kazakhstan TOO Kazpromavtomatika Ul. Zhambyla 28 KAZ-100017 Karaganda Phone: +7 7212 / 50 10 00	Malta ALFATRADE Ltd. 99, Paola Hill Malta-Paola PLA 1702 Phone: +421 (0)32 743 04 72
Moldova INTEHSIS SRL bld. Traian 23/1 MD-2060 Kishinev Phone: +420 595 691 150	Netherlands HIFLEX AUTOM. B.V. Woluweerstraat 22 NL-2984 CD Ridderkerk Phone: +31 (0)180 / 46 60 04	Netherlands KONING & HARTMAN B.V. Energieweg 1 NL-2627 AP Delft Phone: +31 (0)15 260 99 06	Portugal Fonseca S.A. R. João Francisco do Casal 87/89 PT-3801-997 Aveiro, Esquelra Phone: +351 (0)234 / 303 900	Romania Sirus Trading & Services Aleea Lacul Morii Nr. 3 RO-060841 Bucuresti, Sector 6 Phone: +40 (0)21 / 430 40 06	Serbia INEA SR d.o.o. Ul. Karadjordjeva 12/217 SER-11300 Smederevo Phone: +386 (026) 461 54 01	Slovakia SIMAP SK Jána Derku 1671 SK-911 01 Trenčín Phone: +421 (0)32 743 04 72
Slovenia INEA RBT d.o.o. Stegne 11 SI-1000 Ljubljana Phone: +386 (0)1 / 513 8116	Switzerland OMNI RAY AG Im Schörl 5 CH-8600 Döbendorf Phone: +41 (0)44 / 802 28 80	Ukraine OOO "CSC-AUTOMATION" 4-B, M. Raskovoyi St. UA-02660 Kiev Phone: +380 (0)44 / 494 33 44	Israel ILAN & GAVISH Ltd. 24 Shenkar St., Kityat Arie IL-49001 Petah-Tikva Phone: +972 (0)3 / 922 18 24	Israel GIRIT CELADON Ltd. 12 Haomanut Street IL-42505 Netanya Phone: +972 (0)9 / 863 39 80	Lebanon CEG LIBAN Cebaco Center/Block A Autostrade DORA Lebanon-Beirut Phone: +961 (0)1 / 240 445	South Africa ADROIT TECHNOLOGIES 20 Waterford Office Park 189 Witkoppen Road ZA-Fourways Phone: +27 (0)11 / 658 8100

Mitsubishi Electric Europe B.V.

Mitsubishi-Electric-Platz 1, 40882 Ratingen
 Tel.: +49(0)2102-4860 Fax: +49(0)2102-4861120
 info@mitsubishi-automation.com
 eu3a.mitsubishielectric.com