

VACON 10
AC DRIVES

QUICK GUIDE

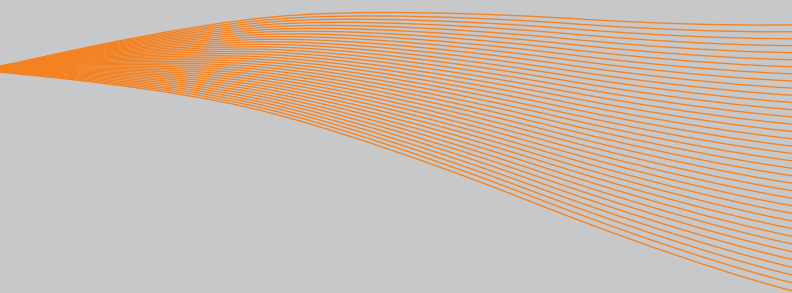

This quick guide includes the essential steps for easy installation and setup of your Vacon 10 frequency converter. Before commissioning your drive, download and read the complete Vacon 10 User Manual available at: www.vacon.com -> Support & Downloads

1. SAFETY



ONLY A COMPETENT ELECTRICIAN IS ALLOWED TO CARRY OUT THE ELECTRICAL INSTALLATION!

This quick guide contains clearly marked warnings which are intended for your personal safety and to avoid any unintentional damage to the product or connected appliances.

Please read these warnings carefully:



The components of the power unit of the frequency converter are live when Vacon 10 is connected to mains. Coming into contact with this voltage is extremely dangerous and may cause death or severe injury.



The motor terminals U, V, W (T1, T2, T3) and the possible brake resistor terminals - / + are live when Vacon 10 is connected to mains, even if the motor is not running.



The control I / O-terminals are isolated from the mains potential. However, the relay output terminals may have a dangerous control voltage present even when Vacon 10 is disconnected from mains.



The earth leakage current of Vacon 10 frequency converters exceeds 3.5 mA AC. According to standard EN61800-5-1, a reinforced protective ground connection must be ensured. **See Chapter 7!**



If the frequency converter is used as a part of a machine, the machine manufacturer is responsible for providing the machine with a main switch (EN 60204-1).



If Vacon 10 is disconnected from mains while running the motor, it remains live if the motor is energized by the process. In this case the motor functions as a generator feeding energy to the frequency converter.



After disconnecting the frequency converter from the mains, wait until the fan stops and the display segments or status leds on the front panel go out. Wait 5 more minutes before doing any work on Vacon 10 connections.



The motor can start automatically after a fault situation, if the autoreset function has been activated.

2. INSTALLATION

2.1 Mechanical installation

There are two possible ways to mount Vacon 10 in the wall. either screw or DIN-rail mounting.

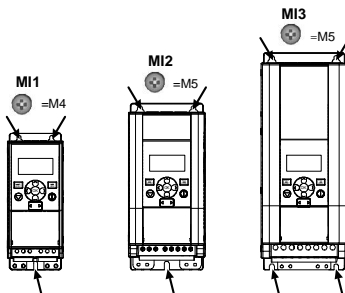

Figure 1: Screw mounting, MI1 - MI3

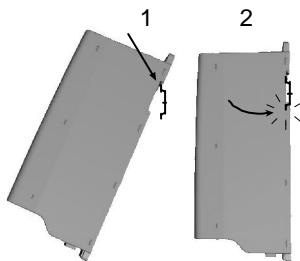

Figure 2: DIN-rail mounting, MI1 - MI3

Note! See the mounting dimensions on the back of the drive. Leave **free space** for cooling above (**100 mm**), below (**50 mm**), and on the sides (**20 mm**) of Vacon 10! [side-to-side installation allowed only if the ambient temperature is below 40 °C.]

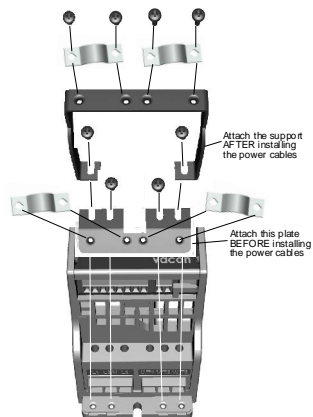

Figure 3: Attaching the PE-plate and API cable support, MI1 - MI3

2.2 Cabling and connections

2.2.1 Power cabling

Note! Tightening torque for power cables is 0.5 - 0.6 Nm

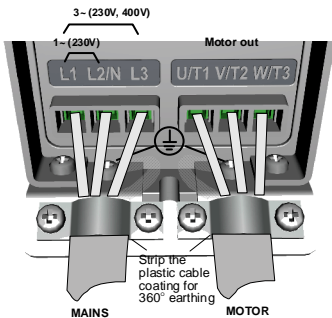

Figure 4: Vacon 10 power connections, M11

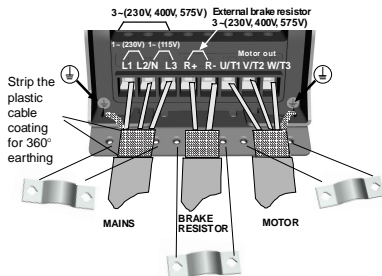

Figure 5: Vacon 10 power connections, M12 - M13

2.2.2 Control cabling



Figure 6: Open the lid MI1 - MI3

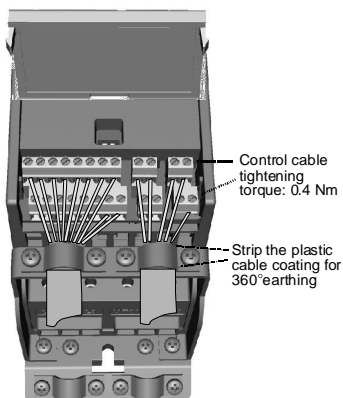
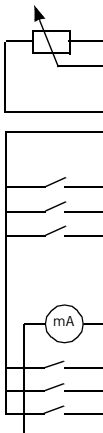

Figure 7: Install the control cables, MI1 - MI3

3. CONTROL I / O AND TERMINALS



Terminal	Signal	Factory preset	Description
1	+10Vre		Ref. voltage out
2	AI1	Freq. reference ^{P)}	Maximum load 10 mA 0 - 10 V Ri = 200 k Ω (min)
3	GND		I/O signal ground
6	24Vout		24V output for DI's ±20 %, max. load 50 mA
7	GND		I/O signal ground
8	DI1	Start forward ^{P)}	0 - +30 V Ri = 12 kΩmin
9	DI2	Start reverse ^{P)}	
10	DI3	Fault reset ^{P)}	
A	A	FB Communication	Negative
B	B	FB Communication	Positive
4	AI2	PI actual value ^{P)}	0(4) - 20 mA, Ri = 200Ω
5	GND		I/O signal ground
13	GND		I/O signal ground
14	DI4	Preset speed B0 ^{P)}	0 - +30 V Ri = 12 kΩ (min)
15	DI5	Preset speed B1 ^{P)}	
16	DI6	External fault ^{P)}	
18	AO	Output frequency ^{P)}	0(4) - 20 mA, RL = 500Ω
20	DO	Active = READY ^{P)}	Open collector, max. load 48V/50mA
22	RO 13	Relay out 1	Active = RUN ^{P)}
23	RO 14		
24	RO 22	Relay out 2	Active = FAULT ^{P)}
25	RO 21		
26	RO 24		

Table 3.1: Vacon 10 default I/O configuration and connections
^{P)} = Programmable function, see parameter lists and descriptions, chapters 8 and 9.

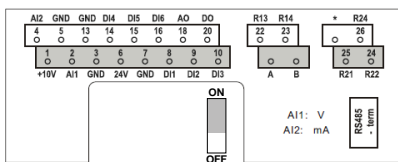

Figure 3.1: Vacon 10 I / O

4. NAVIGATION & STARTUP

4.1 The main menus of Vacon 10

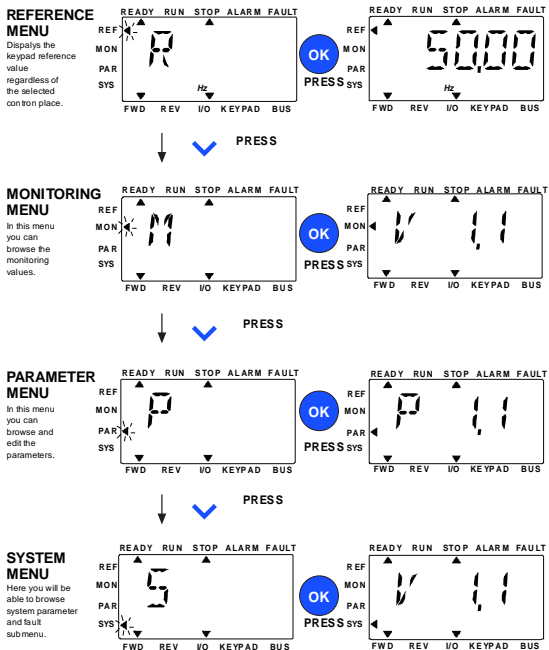

Figure 1: The main menu of Vacon 10

4.2 Commissioning and startup wizard

4.2.1 Commissioning steps:

1. Read safety instructions on page 1	7. Perform test run without motor , see the User Manual at www.vacon.com
2. Secure the grounding and check that cables comply with requirements	8. Run no-load tests without motor being connected to the process
3. Check quality and quantity of cooling air	9. Perform an identification run (Par. ID631)
4. Check that all start / stop switches are in STOP position	10. Connect the motor to the process and perform test run once again
5. Connect the drive to mains	11. Vacon 10 is now ready for use
6. Run the Startup wizard and set all necessary parameters	

Table 1: Commissioning steps

4.2.2 Startup wizard

Vacon 10 runs the startup wizard in first power-up. The wizard can be run by setting SYS Par.4.2 =1. The following figures show the procedure.

NOTE! Running the startup wizard will always return all parameter settings to their factory defaults!

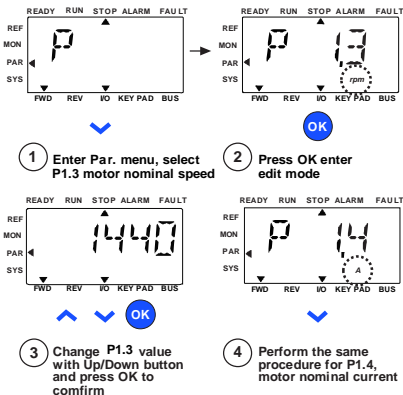
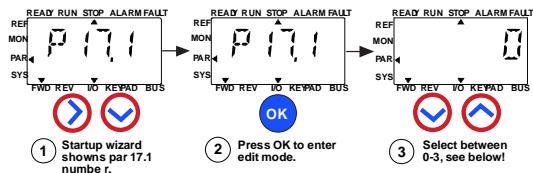

Figure 2: Vacon 10 startup wizard (standard application)



Selections:

	P1.1	P1.2	P1.7	P1.8	P1.15	P2.1	P2.2	P2.3	P3.1	P3.2	P3.3	P4.2	P4.3
0 = Basic	v	50/60 Hz	1.5 x INMDT	0= Frequency control	0= Not used	IO	0= Ramp	0= Coast	0 Hz	50/60 Hz	4=All 0-10V	3s	3s
1 = Pump drive	v	50/60 Hz	1.1 x INMDT	0= Frequency control	0= Not used	IO	0= Ramp	1= Ramp	20 Hz	50/60 Hz	4=All 0-10V	5s	5s
2 = Fan drive	v	50/60 Hz	1.1 x INMDT	0= Frequency control	0= Not used	IO	1= Flying	0= Coast	20 Hz	50/60 Hz	4=All 0-10V	20s	20s
3 = High Torque drive	v	50/60 Hz	1.5 x INMDT	1=Open loop speed control	1= used	IO	0= Ramp	0= Coast	0 Hz	50/60 Hz	4=All 0-10V	1s	1s

*Same as drive voltage, except in 115V drives this value is 230V

Parameters affected:

P1.1 Motor Un (V)	P2.3 Stop function
P1.2 Motor fn (Hz)	P3.1 Min frequency
P1.7 Current limit (A)	P3.2 Max frequency
P1.8 Motor control mode	P3.3 I/O reference
P1.15 Torque boost	P4.2 Acc. time (s)
P2.1 Control place	P4.3 Dec time (s)
P2.2 Start function	



Figure 3: Drive setup

5. MONITORING & PARAMETERS

NOTE! This guide is for Vacon 10 standard application, if you are using a special application, please download the application manual on: www.vacon.com -> Support & downloads.

5.1 Monitoring values

Code	Monitoring signal	Unit	ID	Description
V1.1	Output frequency	Hz	1	Output frequency to motor
V1.2	Frequency reference	Hz	25	Frequency reference to motor control
V1.3	Motor speed	rpm	2	Calculated motor speed
V1.4	Motor current	A	3	Measured motor current
V1.5	Motor torque	%	4	Calculated actual / nominal torque of the motor
V1.6	Output Power	KW	79	Output power from drive to motor
V1.7	Motor voltage	V	6	Motor voltage
V1.8	DC-link voltage	V	7	Measured DC-link voltage
V1.9	Drive temperature	°C	8	Heatsink temperature
V1.10	Motor temperature	%	9	Calculated motor temperature
V2.1	Analog input 1	%	13	AI1 signal range in percent of used range
V2.2	Analog input 2	%	14	AI2 signal range in percent of used range
V2.3	Analog output	%	26	AO signal range in percent of used range
V2.4	Digital input status DI1, DI2, DI3		15	Digital input status
V2.5	Digital input status DI4, DI5, DI6		16	Digital input status
V2.6	RO1, RO2, DO		17	Relay / digital output status
V4.1	PI setpoint	%	20	Regulator setpoint
V4.2	PI feedback value	%	21	Regulator actual value
V4.3	PI error	%	22	Regulator error
V4.4	PI output	%	23	Regulator output

Table 5.1: Vacon 10 monitoring signals

5.2 Quick setup parameters (Virtual menu, shows when par. 17.2 = 1)

Code	Parameter	Min	Max	Unit	Default	ID	Note
P1.1	Motor nominal voltage	180	690	V	Varies	110	Check rating plate on the motor.
P1.2	Motor nominal frequency	30,00	320,00	Hz	50,00 / 60,00	111	Check rating plate on the motor.
P1.3	Motor nominal speed	30	20000	rpm	1440 / 1720	112	Default applies for a 4-pole motor.
P1.4	Motor nominal current	0,2 x I _{Nunit}	2,0 x I _{Nunit}	A	I _{Nunit}	113	Check rating plate on the motor.
P1.5	Motor cos Φ (Power Factor)	0,30	1,00		0,85	120	Check rating plate on the motor.
P1.7	Current limit	0,2 x I _{Nunit}	2,0 x I _{Nunit}	A	1,5 x I _{Nunit}	107	Maximum motor current
P1.15	Torque boost	0	1		0	109	0 = Not used 1 = Used
P2.1	Remote control place 1 selection	0	1		0	172	0 = I / O terminal 1 = Fieldbus
P2.2	Start function	0	1		0	505	0 = Ramp 1 = Flying start
P2.3	Stop function	0	1		0	506	0 = Coasting 1 = Ramp
P3.1	Min frequency	0,00	P3.2	Hz	0,00	101	Minimum freq reference
P3.2	Max frequency	P3.1	320,00	Hz	50,00 / 60,00	102	Maximum freq reference
P3.3	Remote Control Place 1 frequency reference selection	1	6		4	117	1 = Preset Speeds 0-7 2 = Keypad 3 = Fieldbus 4 = AI1 5 = AI2 6 = PI
P3.4	Preset speed 0	P3.1	P3.2	Hz	5,00	124	Activated by digital inputs
P3.5	Preset speed 1	P3.1	P3.2	Hz	10,00	105	Activated by digital inputs
P3.6	Preset speed 2	P3.1	P3.2	Hz	15,00	106	Activated by digital inputs
P3.7	Preset speed 3	P3.1	P3.2	Hz	20,00	126	Activated by digital inputs

Table 5.1: Quick setup parameters

Code	Parameter	Min	Max	Unit	Default	ID	Note
P4.2	Acceleration time 1	0,1	3000,0	s	3,0	103	Acceleration time from 0 Hz to maximum frequency.
P4.3	Deceleration time 1	0,1	3000,0	s	3,0	104	Deceleration time from maximum frequency to 0 Hz.
P6.1	AI1 Signal range	0	1		0	379	0 = 0 - 100% 1 = 20% - 100% 20% is the same as 2 V minimum signal level.
P6.5	AI2 Signal range	0	1		0	390	0 = 0 - 100% 1 = 20% - 100% 20% is the same as 4 mA minimum signal level.
P14.1	Automatic reset	0	1		0	731	0 = Disable 1 = Enable
P17.2	Parameter conceal	0	1		1	115	0 = All parameters visible 1 = Only quick setup parameter group visible

Table 5.1: Quick setup parameters

5.3 Motor settings (Control panel: Menu PAR -> P1)

Code	Parameter	Min	Max	Unit	Default	ID	Note
P1.1	Motor nominal voltage	180	690	V	Varies	110	Check rating plate on the motor
P1.2	Motor nominal frequency	30,00	320,00	Hz	50,00 / 60,00	111	Check rating plate on the motor
P1.3	Motor nominal speed	30	20000	rpm	1440 / 1720	112	Default applies for a 4-pole motor.
P1.4	Motor nominal current	0,2 x I_{Nunit}	2,0 x I_{Nunit}	A	I_{Nunit}	113	Check rating plate on the motor
P1.5	Motor cos Φ (Power Factor)	0,30	1,00		0,85	120	Check rating plate on the motor
P1.6	Motor type	0	1		0	650	0 = Induction 1 = Permanent magnet
P1.7	Current limit	0,2 x I_{Nunit}	2,0 x I_{Nunit}	A	1,5 x I_{Nunit}	107	Maximum motor current
P1.8	Motor control mode	0	1		0	600	0 = Frequency control 1 = Open loop speed control
P1.9	U / f ratio	0	2		0	108	0 = Linear 1 = Quadratic 2 = Programmable
P1.10	Field weakening point	8,00	320,00	Hz	50,00 / 60,00	602	Field weakening point frequency
P1.11	Field weakening point voltage	10,00	200,00	%	100,00	603	Voltage at field weakening point as % of U_{nmot}
P1.12	U / f mid point frequency	0,00	P1.10	Hz	50,00 / 60,00	604	Mid point frequency for programmable U / f
P1.13	U / f mid point voltage	0,00	P1.11	%	100,00	605	Mid point voltage for programmable U / f as % of U_{nmot}
P1.14	Zero freq voltage	0,00	40,00	%	Varies	606	Voltage at 0 Hz as % of U_{nmot}
P1.15	Torque Boost	0	1		0	109	0 = Disabled 1 = Enabled
P1.16	Switching frequency	1,5	16,0	kHz	4,0 / 2,0	601	PWM frequency. If values are higher than default, reduce the current capacity
P1.17	Brake Chopper	0	2		0	504	0 = Disabled 1 = Enabled: Always 2 = Run state

Table 5.2: Motor settings

Code	Parameter	Min	Max	Unit	Default	ID	Note
P1.18	Motor identification	0	1		0	631	0 = Not active 1 = Standstill identification (need run command within 20 s to activate)
P1.19	Rs voltage drop	0,00	100,00	%	0,00	675	Voltage drop over motor windings as % of $U_{n\text{mot}}$ at nominal current.
P1.20	Overvoltage controller	0	2		1	607	0 = Disabled 1 = Enabled, Standard mode 2 = Enabled, Shock load mode
P1.21	Undervoltage controller	0	1		1	608	0 = Disable 1 = Enable

Table 5.2: Motor settings

NOTE! These parameters are shown, when P17.2 = 0.

5.4 Start / stop setup (Control panel: Menu PAR -> P2)

Code	Parameter	Min	Max	Unit	Default	ID	Note
P2.1	Remote Control Place 1 Selection	0	1		0	172	0 = I / O terminals 1 = Fieldbus
P2.2	Start function	0	1		0	505	0 = Ramp 1 = Flying start
P2.3	Stop function	0	1		0	506	0 = Coasting 1 = Ramp
P2.4	I / O Start / Stop logic	0	3		2	300	I / O control signal 1 I / O control signal 2 0 Forward Backward 1 Fwd(edge) Inverted Stop 2 Fwd(edge) Bwd(edge) 3 Start Reverse
P2.5	Local / Remote	0	1		0	211	0 = Remote control 1 = Local control
P2.6	Keypad control direction	0	1		0	123	0 = Forward 1 = Backward

Table 5.3: Start / stop setup

5.5 Frequency references (Control panel: Menu PAR -> P3)

Code	Parameter	Min	Max	Unit	Default	ID	Note
P3.1	Min frequency	0,00	P3.2	Hz	0,00	101	
P3.2	Max frequency	P3.1	320,00	Hz	50,00 / 60,00	102	
P3.3	Remote Control Place 1 fre- quency refer- ence selection	1	6		4	117	1 = Preset Speeds 0 2 = Keypad 3 = Fieldbus 4 = AI1 5 = AI2 6 = PI
P3.4	Preset speed 0	P3.1	P3.2	Hz	5,00	124	Activated by digital inputs
P3.5	Preset speed 1	P3.1	P3.2	Hz	10,00	105	Activated by digital inputs
P3.6	Preset speed 2	P3.1	P3.2	Hz	15,00	106	Activated by digital inputs
P3.7	Preset speed 3	P3.1	P3.2	Hz	20,00	126	Activated by digital inputs
P3.8	Preset speed 4	P3.1	P3.2	Hz	25,00	127	Activated by digital inputs
P3.9	Preset speed 5	P3.1	P3.2	Hz	30,00	128	Activated by digital inputs
P3.10	Preset speed 6	P3.1	P3.2	Hz	40,00	129	Activated by digital inputs
P3.11	Preset speed 7	P3.1	P3.2	Hz	50,00	130	Activated by digital inputs

Table 5.4: Frequency references

NOTE! These parameters are shown, when P17.2 = 0.

5.6 Ramps and brakes setup (Control panel: Menu PAR -> P4)

Code	Parameter	Min	Max	Unit	Default	ID	Note
P4.1	Ramp S-shape	0,0	10,0	s	0,0	500	0 = Linear >0 = S-curve ramp time
P4.2	Acceleration time 1	0,1	3000,0	s	3,0	103	
P4.3	Deceleration time 1	0,1	3000,0	s	3,0	104	
P4.4	Ramp S-shape 2	0,0	10,0	s	0,0	501	
P4.5	Acceleration time 2	0,1	3000,0	s	10,0	502	
P4.6	Deceleration time 2	0,1	3000,0	s	10,0	503	
P4.7	Flux Braking	0	3		0	520	0 = Off 1 = Deceleration 2 = Chopper 3 = Full Mode
P4.8	Flux Braking Current	0,5 x I_{Nunit}	2,0 x I_{Nunit}	A	I_{Nunit}	519	
P4.9	DC Braking Current	0,3 x I_{Nunit}	2,0 x I_{Nunit}	A	I_{Nunit}	507	Defines the current injected into the motor during DC braking.
P4.10	Stop DC current time	0,00	600,00	s	0,00	508	Determines if braking is ON or OFF and the braking time of the DC-brake when the motor is stopping. 0 = Not active
P4.11	Stop DC current frequency	0,10	10,00	Hz	1,50	515	The output frequency at which the DC-braking is applied.
P4.12	Start DC current time	0,00	600,00	s	0,00	516	0 = Not active

Table 5.5: Ramps and brakes setup

5.7 Digital inputs (Control panel: Menu PAR -> P5)

Code	Parameter	Min	Max	Unit	Default	ID	Note
P5.1	I/O control signal 1	0	6		1	403	0 = Not used 1 = DI1 2 = DI2 3 = DI3 4 = DI4 5 = DI5 6 = DI6
P5.2	I/O control signal 2	0	6		2	404	As parameter 5.1
P5.3	Reverse	0	6		0	412	As parameter 5.1
P5.4	Ext. fault Close	0	6		6	405	As parameter 5.1
P5.5	Ext. fault Open	0	6		0	406	As parameter 5.1
P5.6	Fault reset	0	6		3	414	As parameter 5.1
P5.7	Run enable	0	6		0	407	As parameter 5.1
P5.8	Preset speed B0	0	6		4	419	As parameter 5.1
P5.9	Preset speed B1	0	6		5	420	As parameter 5.1
P5.10	Preset speed B2	0	6		0	421	As parameter 5.1
P5.11	Ramp time 2 selection	0	6		0	408	As parameter 5.1
P5.12	Disable PI	0	6		0	1020	As parameter 5.1
P5.13	Force to I/O	0	6		0	409	As parameter 5.1

Table 5.6: Digital inputs

5.8 Analogue inputs (Control panel: Menu PAR -> P6)

Code	Parameter	Min	Max	Unit	Default	ID	Note
P6.1	AI1 Signal range	0	1		0	379	0 = 0 - 100% (0 - 10 V) 1 = 20% - 100% (2 - 10 V)
P6.2	AI1 Custom min	-100,00	100,00	%	0,00	380	0,00 = no min scaling
P6.3	AI1 Custom max	-100,00	300,00	%	100,00	381	100,00 = no max scaling
P6.4	AI1 filter time	0,0	10,0	s	0,1	378	0 = no filtering
P6.5	AI2 signal range	0	1		0	390	0 = 0 - 100% (0 - 20 mA) 1 = 20% - 100% (4 - 20 mA)
P6.6	AI2 Custom min	-100,00	100,00	%	0,00	391	0,00 = no min scaling
P6.7	AI2 Custom max	-100,00	300,00	%	100,00	392	100,00 = no max scaling
P6.8	AI2 filter time	0,0	10,0	s	0,1	389	0 = no filtering

Table 5.7: Analogue inputs

5.9 Digital outputs (Control panel: Menu PAR -> P8)

Code	Parameter	Min	Max	Unit	Default	ID	Selections
P8.1	RO1 signal selection	0	11		2	313	0 = Not used 1 = Ready 2 = Run 3 = Fault 4 = Fault Inverted 5 = Warning 6 = Reversed 7 = At Speed 8 = Motor regulator active 9 = FB Control Word.B13 10 = FB Control Word.B14 11 = FB Control Word.B15
P8.2	RO2 signal selection	0	11		3	314	As parameter 8.1
P8.3	DO1 signal selection	0	11		1	312	As parameter 8.1
P8.4	RO2 inversion	0	1		0	489	0 = No inversion 1 = Inverted

Table 5.8: Digital outputs

5.10 Analogue outputs (Control panel: Menu PAR -> P9)

Code	Parameter	Min	Max	Unit	Default	ID	Selections
P9.1	Analog output signal selection	0	4		1	307	0 = Not used 1 = Output freq. ($0-f_{max}$) 2 = Output current ($0-I_{nMotor}$) 3 = Motor torque ($0-T_{nMotor}$) 4 = PI output (0 - 100%)
P9.2	Analog output minimum	0	1		0	310	0 = 0 mA 1 = 4 mA

Table 5.9: Analogue outputs

5.11 Protections (Control panel: Menu PAR -> P13)

Code	Parameter	Min	Max	Unit	Default	ID	Note
P13.1	Analog Input low fault	0	2		1	700	0 = No action 1 = Alarm 2 = Fault: Coast
P13.2	Under voltage fault	1	2		2	727	1 = No response (no fault generated but drive still stops modulation) 2 = Fault:Coast
P13.3	Earth fault	0	2		2	703	As parameter 13.1
P13.4	Output Phase Fault	0	2		2	702	As parameter 13.1
P13.5	Stall protection	0	2		0	709	As parameter 13.1
P13.6	Under load protection	0	2		0	713	As parameter 13.1
P13.7	Motor thermal protection	0	2		2	704	As parameter 13.1
P13.8	Mtp:Ambient temperature	-20	100	°C	40	705	Environment temperature
P13.9	Mtp:Zero speed cooling	0,0	150,0	%	40,0	706	Cooling as % at 0 speed
P13.10	Mtp:Thermal time constant	1	200	min	45	707	Motor thermal time constant

Table 5.10: Protections

NOTE! These parameters are shown, when P17.2 = 0.

5.12 Fault autoreset parameters (Control panel: Menu PAR -> P14)

Code	Parameter	Min	Max	Unit	Default	ID	Note
P14.1	Automatic Reset	0	1		0	731	0 = Disabled 1 = Enable
P14.2	Wait time	0,10	10,00	s	0,50	717	Waiting time after fault
P14.3	Trial time	0,00	60,00	s	30,00	718	Maximum time for trials
P14.5	Restart Function	0	2		2	719	0 = Ramping 1 = Flying 2 = From Start Function

Table 5.11: Fault autoreset parameters

NOTE! These parameters are shown, when P17.2 = 0.

5.13 PI control parameters (Control panel: Menu PAR -> P15)

Code	Parameter	Min	Max	Unit	Default	ID	Note
P15.1	Setpoint selection	0	3		0	332	0 = Fixed setpoint % 1 = AI1 2 = AI2 3 = Field-bus (ProcessDataIn1)
P15.2	Fixed setpoint	0,0	100,0	%	50,0	167	Fixed setpoint
P15.4	Feedback value selection	0	2		1	334	0 = AI1 1 = AI2 2 = Field-bus (ProcessDataIn2)
P15.5	Feedback value minimum	0,0	50,0	%	0,0	336	Value at minimum signal
P15.6	Feedback value maximum	10,0	300,0	%	100,0	337	Value at maximum signal
P15.7	P gain	0,0	1000,0	%	10,00	118	Proportional gain
P15.8	I time	0,00	320,00	s	10,00	119	Integrative time
P15.10	Error inversion	0	1		0	340	0 = Direct (Feedback < Setpoint -> Increase PID output) 1 = Inverted (Feedback > Setpoint -> Decrease PID output)

Table 5.12: PI control parameters

NOTE! These parameters are shown, when **P17.2 = 0**.

5.14 Application Setting (Control panel: Menu PAR -> P17)

Code	Parameter	Min	Max	Unit	Default	ID	Note
P17.1	Application Type	0	3		0	540	0 = Basic 1 = Pump 2 = Fan drive 3 = High Torque NOTE! Visible only when Startup wizard is active.
P17.2	Parameter conceal	0	1		1	115	0 = All parameters visible 1 = Only quick setup parameter group visible

Table 5.13: Application Setting parameters

5.15 System parameters

Code	Parameter	Min	Max	Default	ID	Note
Software information (MENU PAR -> V1)						
V1.1	API SW ID				2314	
V1.2	API SW version				835	
V1.3	Power SW ID				2315	
V1.4	Power SW version				834	
V1.5	Application ID				837	
V1.6	Application revision				838	
V1.7	System load				839	
V2.1	Communication status				808	Status of Modbus communication. Format: xx.yyy where xx = 0 - 64 (Number of error messages) yyy = 0 - 999 (Number of good messages)
P2.2	Fieldbus protocol	0	1	0	809	0 = Not used 1 = Modbus used
P2.3	Slave address	1	255	1	810	
P2.4	Baud rate	0	8	5	811	0 = 300 1 = 600 2 = 1200 3 = 2400 4 = 4800 5 = 9600 6 = 19200 7 = 38400 8 = 57800
P2.7	Communication time out	0	255	0	814	0 = Not used 1 = 1 sec 2 = 2 secs, etc
P2.8	Reset communication status	0	1	0	815	

Table 5.14: System parameters

Code	Parameter	Min	Max	Default	ID	Note
Other information						
V3.1	MWh counter				827	Million Watt Hour
V3.2	Power on days				828	
V3.3	Power on hours				829	
V3.4	Run counter: Days				840	
V3.5	Run counter: Hours				841	
V3.6	Fault counter				842	
V3.7	Panel parameter set status monitor					
P4.2	Restore factory defaults	0	1	0	831	1 = Restores factory defaults for all parameters
F5.x	Active Fault menu					
F6.x	Fault History menu					

Table 5.14: System parameters

6. FAULT TRACING

Fault code	Fault name	Fault code	Fault name
1	Overcurrent	22	EEPROM checksum fault
2	Overvoltage	25	Microcontroller watchdog fault
3	Earth fault	27	Back EMF protection
8	System fault	34	Internal bus communication
9	Undervoltage	35	Application fault
11	Output phase fault	41	IGBT Overtemperature
13	Frequency converter undertemperature	50	Analog input select 20% - 100% (selected signal range 4 to 20 mA or 2 to 10 V)
14	Frequency converter overtemperature	51	External fault
15	Motor stalled	53	Fieldbus fault
16	Motor overtemperature	57	Identification fault
17	Motor underload		

Table 1: Fault codes. See User Manual for detailed fault descriptions.

7. GENERAL DATA

Dimensions and weight	Frame	Height	Width	Depth (mm)	Weight (kg)
	MI1	157	66	98	0.5
	MI2	195	90	102	0.7
	MI3	262	100	109	1
Supply network	Networks	Vacon 10 (400 V) cannot be used with corner grounded networks			
	Short circuit current	Maximum short circuit current has to be < 50 kA			
Motor connection	Output voltage	0 - U_{In}			
	Output current	Continuous rated current I_N at ambient temperature max. +50 °C (depends on the unit size), overload 1.5 x I_N max. 1 min / 10 min			
Ambient conditions	Ambient operating temperature	-10 °C (no frost)...+40 / 50 °C (depends on the unit size); rated loadability I_N Side by side installation for MI1-3 it is always 40 °C; For IP21 / Nema1 option in MI1-3 the maximum temperature is also 40 °C.			
	Storage temperature	-40 °C...+70 °C			
	Relative humidity	0...95% RH, non-condensing, non-corrosive, no dripping water			
	Altitude	100% load capacity (no derating) up to 1000 m. 1% derating for each 100 m above 1000 m; max. 2000 m			
	Enclosure class	IP20 / IP21 / Nema1 for MI1-3.			
	Pollution degree	PD2			
EMC	Immunity	Complies with EN50082-1, -2, EN61800-3			
	Emissions (See detailed descriptions in Vacon 10 User Manual at: www.vacon.com)	230V : Complies with EMC category C2; With an internal RFI filter. 400V: Complies with EMC category C2; With an internal RFI filter Both: No EMC emission protection (Vacon level N); Without RFI filter			
Standards	For EMC: EN61800-3, For safety: UL508C, EN61800-5				
Certificates and manufacturer's declarations of conformity	For safety: CB, CE, UL, cUL, For EMC: CE, CB, c-tick (see unit nameplate for more detailed approvals)				

Cable and fuse requirements (See detailed data in Vacon 10 User Manual at: www.vacon.com) 380 - 480 V, 3~ 208 - 240 V, 3~	Frame	Fuse (A)	Mains cable Cu (mm ²)	Terminal cable min-max (mm ²)		
				Main	Earth	Control & relay
	MI1	6	3*1.5+1.5	1.5-4		0.5-1.5
	MI2	10				
	MI3	20	1.5-6			
115 V, 1~	MI2	20	2*2.5+2.5	1.5-4		
	MI3	32	2*6+6			
208 - 240, 1~	MI1	10	2*1.5+1.5	1.5-4		
	MI2	20	2*2.5+2.5			
	MI3	32	2*6+6	1.5-6		
575V	MI3	6	3*1.5+1.5	1.5-4		
	MI3	10				
	MI3	20	3*2.5+2.5	1.5-6		

- With above-mentioned fuses, the drive can be connected to power supply the short circuit current of which is max. 50 kA
- Use cables with heat resistance of at least +70 °C.
- The fuses function also as cable overload protection.
- These instructions apply only to cases with one motor and one cable connection from the frequency converter to the motor.
- To fulfil standard EN61800-5-1, the protective conductor should be **at least 10 mm² Cu or 16 mm² Al**. Another possibility is to use an additional protective conductor of at least the same size as the original one.

Vacon 10 power ratings

Mains voltage 208 - 240 V, 50 / 60 Hz, 1~ series							
Freq. converter type	Rated loadability		Motor shaft power		Nominal input current [A]	Mechanical size	Weight (kg)
	100% contin. current I_N [A]	150% over-load current [A]	P [HP]	P [KW]			
0001	1.7	2.6	0.33	0.25	4.2	MI1	0.55
0002	2.4	3.6	0.5	0.37	5.7	MI1	0.55
0003	2.8	4.2	0.75	0.55	6.6	MI1	0.55
0004	3.7	5.6	1	0.75	8.3	MI2	0.55
0005	4.8	7.2	1.5	1.1	11.2	MI2	0.7
0007	7	10.5	2	1.5	14.1	MI2	0.7
0009*	9.6	14.4	3	2.2	22.1	MI3	0.99

Table 1: Vacon 10 power ratings, 208 - 240 V

* The maximum ambient operating temperature of this drive is 40 °C!

Mains voltage 208 - 240 V, 50 / 60 Hz, 3~ series							
Freq. converter type	Rated loadability		Motor shaft power		Nominal input current [A]	Mechanical size	Weight (kg)
	100% contin. current I_N [A]	150% over-load current [A]	P HP	P [KW]			
0001	1.7	2.6	0.33	0.25	2.7	MI1	0.55
0002	2.4	3.6	0.5	0.37	3.5	MI1	0.55
0003	2.8	4.2	0.75	0.55	3.8	MI1	0.55
0004	3.7	5.6	1	0.75	4.3	MI2	0.7
0005	4.8	7.2	1.5	1.1	6.8	MI2	0.7
0007*	7	10.5	2	1.5	8.4	MI2	0.7
0011*	11	16.5	3	2.2	13.4	MI3	0.99

Table 2: Vacon 10 power ratings, 208 - 240 V, 3~

*The maximum ambient operating temperature of this drive is +40°C !

Mains voltage 115 V, 50 / 60 Hz, 1~ series							
Freq. converter type	Rated loadability		Motor shaft power		Nominal input current [A]	Mechanical size	Weight (Kg)
	100% contin. current I_N [A]	150% over-load current [A]	P [HP]	P [KW]			
0001	1.7	2.6	0.33	0.25	9.2	MI2	0.7
0002	2.4	3.6	0.5	0.37	11.6	MI2	0.7
0003	2.8	4.2	0.75	0.55	12.4	MI2	0.7
0004	3.7	5.6	1	0.75	15	MI2	0.7
0005	4.8	7.2	1.5	1.1	16.5	MI3	0.99

Table 3: Vacon 10 power ratings, 115 V, 1~

Mains voltage 380 - 480 V, 50 / 60 Hz, 3~ series							
Freq. converter type	Rated loadability		Motor shaft power		Nominal input current [A]	Mechanical size	Weight (kg)
	100% contin. current I_N [A]	150% over-load current [A]	P [HP]	P [KW]			
0001	1.3	2	0.5	0.37	2.2	MI1	0.55
0002	1.9	2.9	0.75	0.55	2.8	MI1	0.55
0003	2.4	3.6	1	0.75	3.2	MI1	0.55
0004	3.3	5	1.5	1.1	4	MI2	0.7
0005	4.3	6.5	2	1.5	5.6	MI2	0.7
0006	5.6	8.4	3	2.2	7.3	MI2	0.7
0008	7.6	11.4	4	3	9.6	MI3	0.99
0009	9	13.5	5	4	11.5	MI3	0.99
0012	12	18	7.5	5.5	14.9	MI3	0.99

Table 4: Vacon 10 power ratings, 380 - 480 V

* The maximum ambient operating temperature of these drives is +50 °C

Mains voltage 575 V, 50 / 60 Hz, 3~ series							
Freq. converter type	Rated loadability		Motor shaft power		Nominal input current [A]	Mechanical size	Weight (kg)
	100% contin. current I_N [A]	150% over-load current [A]	P [HP]	P [kW]			
0002	1,7	2,6	1	0,75	2	MI3	0,99
0003	2,7	4,2	2	1,5	3,6	MI3	0,99
0004	3,9	5,9	3	2,2	5	MI3	0,99
0006	6,1	9,2	5	3,7	7,6	MI3	0,99
0009	9	13,5	7,5	5,5	10,4	MI3	0,99

Table 5: Vacon 10 power ratings, 575 V

Note: The input currents are calculated values with 100 kVA line transformer supply.

Quick Modbus setup

1	A: Select Fieldbus as remote control place: P2.1 to1 – Fieldbus B: Set Modbus RTU protocol to "ON": S2.2 to 1 – Modbus
2	A. Set Control Word to "0" (2001) B. Set Control Word to "1" (2001) C. Frequency converter status is RUN D. Set Reference value to "5000" (50,00%) (2003) E. Actual Speed is 5000 (25.00 Hz if MinFreq is 0.00 Hz and MaxFreq is 50.00 Hz) F. Set Control Word to "0" (2001) G. Frequency converter status is STOP

VACON

DRIVEN BY DRIVES

Find your nearest Vacon office
on the Internet at:

www.vacon.com

Manual authoring:
documentation@vacon.com

VaconPlc
Runsorintie 7
65380 Vaasa
Finland

Document ID:



Subject to change without prior notice
©2011 Vacon Plc.

Rev.C