

ABB INDUSTRIAL DRIVES

ACS880-01 drives

Hardware manual



ACS880-01 drives

Hardware manual







Table of contents	
1. Safety instructions	
4. Mechanical installation	
6. Electrical installation – IEC	
7. Electrical installation – North America	
10. Start-up	

Table of contents

1 Safety instructions

Contents of this chapter	13
Use of warnings and notes	13
General safety in installation, start-up and maintenance	14
Electrical safety in installation, start-up and maintenance	15
Electrical safety precautions	15
Additional instructions and notes	16
Optical components	16
Printed circuit boards	16
Grounding	17
General safety in operation	18
Additional instructions for permanent magnet motor drives	18
Safety in installation, start-up, maintenance	18
Safety in operation	19

2 Introduction to the manual

Contents of this chapter	21
Applicability	21
Target audience	21
Categorization by frame size and option code	21
Quick installation, commissioning and operation flowchart	22
Terms and abbreviations	22
Related manuals	23

3 Operation principle and hardware description

Contents of this chapter	27
Product overview	27
Main circuit	28
Layout	29
IP21, UL Type 1	29
IP55 (option +B056)	30
UL Type 12 (option +B056)	31
IP20 (UL Type Open, options +P940 and +P944)	31
Overview of power and control connections	32
Control panel	33
Control panel mounting platform cover	33
Control panel door mounting kits	33
Type designation label	34
Type designation key	34
Basic code	34
Option codes	35

4 Mechanical installation

Contents of this chapter	39
Safety	39



Mounting orientations	40
Required free space	40
Examining the installation site	40
Required tools	41
Moving the drive	41
Unpacking and examining the delivery	41
Package of frames R1 to R5	42
Frame R5 cable box (IP21, UL Type 1)	43
Package of frames R6 and R7	45
Frame R6 cable box (IP21, UL Type 1)	47
Frame R7 cable box (IP21, UL Type 1)	48
Package of frames R8 and R9	49
Frame R8 cable box (IP21, UL Type 1)	51
Frame R9 cable box (IP21, UL Type 1)	52
Installing the drive	52
Vibration dampers (option +C131)	52
Flange mounting (option +C135)	53
UK gland plate (option +H358)	53
Cabinet installation (options +P940 and +P944)	53
Frames R1 to R4 (IP21, UL Type 1)	54
Frames R5 to R9 (IP21, UL Type 1)	55
Frames R1 to R9 (IP55, UL Type 12)	57

5 Guidelines for planning the electrical installation

Contents of this chapter	59
Limitation of liability	59
Selecting the main supply disconnecting device	59
European Union	59
North America	60
Other regions	60
Selecting the main contactor	60
Examining the compatibility of the motor and drive	60
Protecting the motor insulation and bearings	60
Requirements table	61
Availability of du/dt filter and common mode filter by drive type	63
Additional requirements for explosion-safe (EX) motors	63
Additional requirements for ABB motors of types other than M2_, M3_, M4_, HX_ and AM_	63
Additional requirements for braking applications	63
Additional requirements for ABB high-output and IP23 motors	63
Additional requirements for non-ABB high-output and IP23 motors	63
Additional data for calculating the rise time and the peak line-to-line voltage	64
Additional note for sine filters	65
Selecting the power cables	65
General guidelines	65
Typical power cable sizes	66
Power cable types	66
Preferred power cable types	66
Alternate power cable types	67
Not allowed power cable types	68
Additional guidelines, North America	68
Metal conduit	69

Power cable shield	69
Selecting the control cables	69
Shielding	69
Signals in separate cables	70
Signals that can be run in the same cable	70
Relay cable	70
Control panel to drive cable	70
PC tool cable	70
Routing the cables	70
General guidelines – IEC	70
General guidelines – North America	71
Continuous motor cable shield/conduit or enclosure for equipment on the motor cable	72
Separate control cable ducts	72
Implementing short-circuit and thermal overload protection	73
Protecting the drive and the input power cable in short-circuits	73
Protecting the motor and motor cable in short-circuits	73
Protecting the motor cables against thermal overload	73
Protecting the motor against thermal overload	73
Protecting the motor against overload without thermal model or temperature sensors using an external overload device	74
Protecting the drive against ground faults	74
Residual current device compatibility	74
Connecting drives to a common DC system	74
Implementing the emergency stop function	74
Implementing the Safe torque off function	75
Implementing the functions provided by the FSO-xx safety functions module	75
Implementing an ATEX-certified motor thermal protection	75
Implementing the Power-loss ride-through function	75
Using power factor compensation capacitors with the drive	76
Controlling a contactor between drive and motor	76
Implementing a bypass connection	77
Example bypass connection	77
Switching the motor power supply from drive to direct-on-line	78
Switching the motor power supply from direct-on-line to drive	78
Protecting the contacts of relay outputs	78
Implementing a motor temperature sensor connection	79
Connecting motor temperature sensor to the drive via an option module	80
Connection of motor temperature sensor to the drive via a relay	80
PTC (IEC 60800-5-1)	80
Pt100 (IEC 90800-5-1)	80
 6 Electrical installation – IEC	
Contents of this chapter	83
Safety	83
Required tools	83
Grounding the motor cable shield at the motor end	83
Measuring the insulation	84
Measuring the insulation of the drive	84
Measuring the insulation of the input power cable	84
Measuring the insulation of the motor and motor cable	84
Measuring the insulation of the brake resistor circuit	85

Grounding system compatibility check	85
Corner-grounded and midpoint-grounded 525...690 V delta systems	85
Connecting the power cables	86
Connection diagram	86
Connection procedure for frames R1 to R3	87
Connection procedure for frames R4 and R5	90
Connection procedure for frames R6 to R9	95
Connecting the control cables	101
Connection process	102
Connecting a PC	104
Panel bus (control of several units from one control panel)	104
Installing option modules	108
Installing FSO-xx safety functions modules	109
Installation procedure	110

7 Electrical installation – North America

Contents of this chapter	111
Safety	111
Required tools	111
Measuring the insulation	111
Grounding system compatibility check	111
Corner-grounded and midpoint-grounded 525...690 V delta systems	112
Connecting the power cables	112
Connection diagram with conduits	112
Connection procedure for frames R1 to R3	114
Connection procedure for frames R4 and R5	116
Connection procedure for frames R6 to R9	120
Connecting the control cables	124
Connection procedure for frames R1 to R3	124
Connection procedure for frames R4 to R5	125
Connection procedure for frames R6 to R9	127
Connecting a PC	130
Panel bus (control of several units from one control panel)	130
Installing option modules	133

8 Control units of the drive

Contents of this chapter	135
ZCU-12 layout	136
Default I/O diagram of the drive control unit (ZCU-1x)	137
Additional information on the connections	139
External power supply for the control unit (XPOW)	139
DI6 as a PTC sensor input	139
AI1 or AI2 as a Pt100, Pt1000, PTC or KTY84 sensor input	139
DIIL input	140
The XD2D connector	140
Safe torque off (XSTO)	141
FSO-xx safety functions module connection (X12)	141
Connector data	142
ZCU-1x ground isolation diagram	144



9 Installation checklist

Contents of this chapter	145
Checklist	145

10 Start-up

Contents of this chapter	147
Start-up procedure	147

11 Fault tracing

Contents of this chapter	149
LEDs	149
Warning and fault messages	149

12 Maintenance

Contents of this chapter	151
Maintenance intervals	151
Descriptions of symbols	151
Recommended annual maintenance actions by the user	152
Recommended maintenance intervals after start-up	152
Heatsink	152
Fans	153
Replacing the main cooling fan of frames R1 to R3	154
Replacing the auxiliary cooling fan of IP55 frames R1 to R3	155
Replacing the main cooling fan of frames R4 and R5	156
Replacing the auxiliary cooling fan of frames R4 and R5	157
Replacing the main cooling fan of frames R6 to R8	159
Replacing the auxiliary cooling fan of frames R6 to R9 (IP21, UL Type 1)	160
Replacing the auxiliary cooling fan of frames R8 and R9 (IP55, UL Type 12)	161
Replacing the main cooling fans of frame R9	163
Replacing the drive (IP21, UL Type 1, frames R1 to R9)	163
Capacitors	164
Reforming the capacitors	164
Control panel	165
Control unit	165
Replacing the memory unit of ZCU-12	165
Replacing the ZCU-12 control unit battery	165
Replacing safety functions modules (FSO-12, option +Q973 and FSO-21, option +Q972)	165

13 Technical data

Contents of this chapter	167
Marine type-approved drives (option +C132)	167
Drives for SynRM motors	167
Ratings	167
Definitions	173
Derating	173
Surrounding air temperature derating	173
IP21 (UL Type 1) drives and IP55 (UL Type 12) frames R1...R7	173
IP55 (UL Type 12) frames R8 and R9	174



Altitude derating	175
Altitude derating	175
Deratings for special settings in the drive control program	175
Ex motor, sine filter, low noise	175
Definitions	178
Definitions	181
High speed mode	181
Definitions	184
Fuses (IEC)	184
aR fuses DIN 43653 stud-mount (frames R1 to R9)	184
aR fuses DIN 43620 blade style (frames R1 to R9)	187
gG fuses DIN 43620 blade style (frames R1 to R9)	191
Quick guide for selecting between gG and aR fuses	194
Calculating the short-circuit current of the installation	196
Calculation example	196
Fuses (UL)	197
Circuit breakers (IEC)	199
ABB miniature and molded case circuit breakers	199
Circuit breakers (UL)	202
ABB inverse time circuit breakers	202
Dimensions, weights and free space requirements	203
Definitions	204
Package dimensions	205
Free space requirements	206
Losses, cooling data and noise	206
Cooling air flow and heat dissipation for flange mounting (option +C135)	208
Connector and entry data for the power cables	210
IEC	210
UL	211
UL listed cable lugs and tools	212
Connector data for the control cables	213
Typical power cable sizes	213
Electrical power network specification	216
Motor connection data	216
Efficiency	217
Protection classes	217
Ambient conditions	217
Materials	218
Applicable standards	218
Markings	219
Compliance with the EN 61800-3:204 + A1:2012	220
Definitions	220
Category C2	221
Category C3	221
Category C4	222
UL and CSA checklist	222
Approvals	223
Design lifetime expectancy	223
Disclaimers	224
Generic disclaimer	224
Cybersecurity disclaimer	224



14 Dimension drawings

Contents of this chapter	225
Frame R1 (IP21, UL Type 1)	226
Frame R1 (IP55, UL Type 12)	227
Frame R2 (IP21, UL Type 1)	228
Frame R2 (IP55, UL Type 12)	229
Frame R3 (IP21, UL Type 1)	230
Frame R3 (IP55, UL Type 12)	231
Frame R4 (IP21, UL Type 1)	232
Frame R4 (IP55, UL Type 12)	233
Frame R5 (IP21, UL Type 1)	234
Frame R5 (IP55, UL Type 12)	235
Frame R6 (IP21, UL Type 1)	236
Frame R6 (IP55, UL Type 12)	237
Frame R7 (IP21, UL Type 1)	238
Frame R7 (IP55, UL Type 12)	239
Frame R8 (IP21, UL Type 1)	240
Frame R8 (IP55, UL Type 12)	241
Frame R9 (IP21, UL Type 1)	242
Frame R9 (IP55, UL Type 12)	243

15 Resistor braking

Contents of this chapter	245
Operation principle and hardware description	245
Planning the braking system	245
Selecting the brake circuit components	245
Selecting a custom resistor	246
Selecting and routing the brake resistor cables	246
Minimizing electromagnetic interference	246
Maximum cable length	247
EMC compliance of the complete installation	247
Placing the brake resistors	247
Protecting the system against thermal overload	247
Frames R1 to R4	247
Frames R5 to R9	248
Protecting the resistor cable against short-circuits	248
Mechanical installation	248
Electrical installation	249
Measuring the insulation of the assembly	249
Connection diagram	249
Connection procedure	249
Start-up	249
Technical data	250
Ratings	250
Degree of protection and thermal constant of the resistor	252
Dimensions and weights of external resistors	253
JBR-03	253
SACE08RE44	254
SACE15RE13 and SACE15RE2	255
SAFUR80F500 and SAFUR90F575	255
SAFUR125F500 and SAFUR200F500	256

16 The Safe torque off function

Contents of this chapter	257
Description	257
Compliance with the European Machinery Directive	258
Wiring	259
Activation switch	259
Cable types and lengths	259
Grounding of protective shields	259
Single drive (internal power supply)	260
Dual-channel connection	260
Single-channel connection	261
Multiple drives	262
Internal power supply	262
External power supply	263
Operation principle	264
Start-up including acceptance test	265
Competence	265
Acceptance test reports	265
Acceptance test procedure	265
Use	267
Maintenance	268
Competence	268
Fault tracing	269
Safety data	270
Abbreviations	271
TÜV certificate	271
Declaration of conformity	272

17 Filters

Contents of this chapter	273
When is a common mode filter or du/dt filter needed?	273
Common mode filters	273
du/dt filters	273
du/dt filter types	273
Description, installation and technical data of the du/dt filters	274
Sine filters	274
Selecting a sine filter for a drive	274
Definitions	276
Derating	277
Description, installation and technical data	277

Further information

1

Safety instructions



Contents of this chapter

This chapter contains the safety instructions which you must obey when you install, start up, operate and do maintenance work on the drive. If you ignore the safety instructions, injury, death or damage can occur.

Use of warnings and notes

Warnings tell you about conditions which can cause injury or death, or damage to the equipment. They also tell you how to prevent the danger. Notes draw attention to a particular condition or fact, or give information on a subject.

The manual uses these warning symbols:

**WARNING!**

Electricity warning tells about hazards from electricity which can cause injury or death, or damage to the equipment.

**WARNING!**

General warning tells about conditions, other than those caused by electricity, which can cause injury or death, or damage to the equipment.

**WARNING!**

Electrostatic sensitive devices warning tells you about the risk of electrostatic discharge which can cause damage to the equipment.

General safety in installation, start-up and maintenance

These instructions are for all personnel who do work on the drive.



WARNING!

Obey these instructions. If you ignore them, injury or death, or damage to the equipment can occur.

- Keep the drive in its package until you install it. After unpacking, protect the drive from dust, debris and moisture.
- Use the required personal protective equipment: safety shoes with metal toe cap, safety glasses, protective gloves and long sleeves, etc. Some parts have sharp edges.
- Lift a heavy drive with a lifting device. Use the designated lifting points. See the dimension drawings.
- Be careful when handling a tall module. The module overturns easily because it is heavy and has a high center of gravity. Whenever possible, secure the module with chains. Do not leave an unsupported module unattended especially on a sloping floor.



- Beware of hot surfaces. Some parts, such as heatsinks of power semiconductors, and brake resistors, remain hot for a while after disconnection of the electrical supply.
- Vacuum clean the area around the drive before the start-up to prevent the drive cooling fan from drawing the dust inside the drive.
- Make sure that debris from drilling, cutting and grinding does not enter the drive during the installation. Electrically conductive debris inside the drive may cause damage or malfunction.
- Make sure that there is sufficient cooling. See the technical data.
- Before you connect voltage to the drive, make sure that all covers are in place. Do not remove the covers when voltage is connected.
- Before you adjust the drive operation limits, make sure that the motor and all driven equipment can operate throughout the set operation limits.
- Before you activate the automatic fault reset or automatic restart functions of the drive control program, make sure that no dangerous situations can occur. These functions reset the drive automatically and continue operation after a fault or supply break. If these functions are activated, the installation must be clearly marked as defined in IEC/EN 61800-5-1, subclause 6.5.3, for example, "THIS MACHINE STARTS AUTOMATICALLY".
- The maximum drive power cycles is five times in ten minutes. Power cycling the drive too often can damage the charging circuit of the DC capacitors.

- If you have connected safety circuits to the drive (for example, Safe torque off or emergency stop), validate them at start-up. See separate instructions for the safety circuits.
- Beware of hot air exiting from the air outlets.
- Do not cover the air inlet or outlet when the drive is running.

Note:

- If you select an external source for the start command and it is on, the drive will start immediately after fault reset unless you configure the drive for pulse start. See the firmware manual.
- If the drive is in remote control mode, you cannot stop or start the drive with the control panel.
- Only authorized persons are allowed to repair a malfunctioning drive.

Electrical safety in installation, start-up and maintenance

■ Electrical safety precautions

These electrical safety precautions are for all personnel who do work on the drive, motor cable or motor.

**WARNING!**

Obey these instructions. If you ignore them, injury or death, or damage to the equipment can occur.

If you are not a qualified electrical professional, do not do installation or maintenance work.

Go through these steps before you begin any installation or maintenance work.

1. Clearly identify the work location and equipment.
2. Disconnect all possible voltage sources. Make sure that re-connection is not possible. Lock out and tag out.
 - Open the main disconnecting device of the drive.
 - If you have a permanent magnet motor connected to the drive, disconnect the motor from the drive with a safety switch or by other means.
 - Disconnect all dangerous external voltages from the control circuits.
 - After you disconnect power from the drive, always wait 5 minutes to let the intermediate circuit capacitors discharge before you continue.
3. Protect any other energized parts in the work location against contact.
4. Take special precautions when close to bare conductors.
5. Measure that the installation is de-energized.
 - Before and after measuring the installation, verify the operation of the voltage tester on a known voltage source.
 - Make sure that the voltage between the drive input power terminals (L1, L2, L3) and the grounding (PE) busbar is zero.
 - Make sure that the voltage between the drive output terminals (T1/U, T2/V, T3/W) and the grounding (PE) busbar is zero.
 - Make sure that the voltage between the drive DC terminals (R+/UDC+ and UDC-) and the grounding (PE) terminal is zero.



6. Install temporary grounding as required by the local regulations.
7. Ask the person in control of the electrical installation work for a permit to work.

■ Additional instructions and notes



WARNING!

Obey these instructions. If you ignore them, injury or death, or damage to the equipment can occur.

If you are not a qualified electrical professional, do not do installation or maintenance work.

- Make sure that the electrical power network, motor/generator, and environmental conditions agree with the drive data.
- Do not do insulation or voltage withstand tests on the drive.
- If you have a cardiac pacemaker or other electronic medical device, keep away from the area near motor, drive, and the drive power cabling when the drive is in operation. There are electromagnetic fields present which can interfere with the function of such devices. This can cause a health hazard.

Note:

- The motor cable terminals of the drive are at a dangerous voltage when the input power is on, regardless of whether the motor is running or not.
- When the input power is on, the drive DC bus is at a dangerous voltage. If brake chopper and resistor are in use, they are at a dangerous voltage. (Option +D150)
- External wiring can supply dangerous voltages to the relay outputs of the control units of the drive.
- The Safe torque off function does not remove the voltage from the main and auxiliary circuits. The function is not effective against deliberate sabotage or misuse.

Optical components



WARNING!

Obey these instructions. If you ignore them, damage to the equipment can occur.

- Handle the fiber optic cables with care.
- When you unplug the fiber optic cables, always hold the connector, not the cable itself.
- Do not touch the ends of the fibers with bare hands as the ends are extremely sensitive to dirt.
- Do not bend the fiber optic cables too tightly. The minimum allowed bend radius is 35 mm (1.4 in).

Printed circuit boards



WARNING!

Use a grounding wrist band when you handle printed circuit boards. Do not touch the boards unnecessarily. The boards contain components sensitive to electrostatic discharge.

■ Grounding

These instructions are for all personnel who are responsible for the grounding of the drive.



WARNING!

Obey these instructions. If you ignore them, injury or death, or equipment malfunction can occur, and electromagnetic interference can increase.

If you are not a qualified electrical professional, do not do grounding work.

- Always ground the drive, the motor and adjoining equipment. This is necessary for the personnel safety. Proper grounding also reduces electromagnetic emission and interference.
- Make sure that the conductivity of the protective earth (PE) conductors is sufficient. See the electrical planning instructions of the drive. Obey the local regulations.
- Connect the power cable shields to protective earth (PE) terminals of the drive to make sure of personnel safety.
- Make a 360° grounding of the power and control cable shields at the cable entries to suppress electromagnetic disturbances.
- In a multiple-drive installation, connect each drive separately to the protective earth (PE) busbar of the power supply.

Note:

- You can use power cable shields as grounding conductors only when their conductivity is sufficient.
- As the normal touch current of the drive is higher than 3.5 mA AC or 10 mA DC, you must use a fixed protective earth (PE) connection. The minimum size of the protective earth conductor must comply with the local safety regulations for high protective earth conductor current equipment. See standard IEC/EN 61800-5-1 (UL 61800-5-1) and the electrical planning instructions of the drive.

To comply with standard IEC/EN 61800-5-1 (UL 61800-5-1)

- use a protective earth conductor with a minimum cross-sectional area of 10 mm² Cu or 16 mm² Al (as an alternative when aluminum cables are permitted),
or
- use a second protective earth conductor of the same cross-sectional area as the original protective earth conductor,
or
- use a device that automatically disconnects the supply if the protective earth conductor is damaged.

If the protective earth conductor is separate (that is, it does not form part of the input power cable or the input power cable enclosure), the minimum cross-sectional area must be:

- 2.5 mm² when the conductor is mechanically protected,
or
- 4 mm² when the conductor is not mechanically protected.



General safety in operation

These instructions are for all personnel that operate the drive.



WARNING!

Obey these instructions. If you ignore them, injury or death, or damage to the equipment can occur.

- If you have a cardiac pacemaker or other electronic medical device, keep away from the area near motor, drive, and the drive power cabling when the drive is in operation. There are electromagnetic fields present which can interfere with the function of such devices. This can cause a health hazard.
- Give a stop command to the drive before you reset a fault. If you have an external source for the start command and the start is on, the drive will start immediately after the fault reset, unless you configure the drive for pulse start. See the firmware manual.
- Before you activate the automatic fault reset or automatic restart functions of the drive control program, make sure that no dangerous situations can occur. These functions reset the drive automatically and continue operation after a fault or supply break. If these functions are activated, the installation must be clearly marked as defined in IEC/EN 61800-5-1, subclause 6.5.3, for example, "THIS MACHINE STARTS AUTOMATICALLY".

Note:

- The maximum drive power cycles is five times in ten minutes. Power cycling the drive too often can damage the charging circuit of the DC capacitors. If you need to start or stop the drive, use the control panel keys or commands through the I/O terminals of the drive.
- If the drive is in remote control mode, you cannot stop or start the drive with the control panel.

Additional instructions for permanent magnet motor drives

■ Safety in installation, start-up, maintenance

These are additional warnings concerning permanent magnet motor drives. The other safety instructions in this chapter are also valid.



WARNING!

Obey these instructions. If you ignore them, injury or death, or damage to the equipment can occur.

If you are not a qualified electrical professional, do not do installation or maintenance work.

- Do not do work on the drive when a rotating permanent magnet motor is connected to it. A rotating permanent magnet motor energizes the drive including its input and output power terminals.

Before installation, start-up and maintenance work on the drive:

- Stop the drive.
- Disconnect the motor from the drive with a safety switch or by other means.

- If you cannot disconnect the motor, make sure that the motor cannot rotate during work. Make sure that no other system, like hydraulic crawling drives, can rotate the motor directly or through any mechanical connection like belt, nip, rope, etc.
- Do the steps in section [Electrical safety precautions \(page 15\)](#).
- Install temporary grounding to the drive output terminals (T1/U, T2/V, T3/W). Connect the output terminals together as well as to the PE.

During the start up:

- Make sure that the motor cannot run overspeed, for example, driven by the load. Motor overspeed causes overvoltage that can damage or destroy the capacitors in the intermediate circuit of the drive.

■ Safety in operation



WARNING!

Make sure that the motor cannot run overspeed, for example, driven by the load. Motor overspeed causes overvoltage that can damage or destroy the capacitors in the intermediate circuit of the drive.



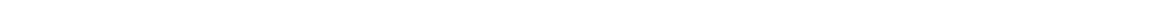



Introduction to the manual

Contents of this chapter

This chapter describes the intended audience and contents of the manual. It contains a flowchart of steps in examining the delivery, installing and commissioning the drive. The flowchart refers to chapters/sections in this manual and other manuals.

Applicability

This manual applies to ACS880-01 drive module units intended for user-defined cabinet installations.

Target audience

This manual is intended for people who plan the installation, install, start up and do maintenance work on the drive, or create instructions for the end user of the drive concerning the installation and maintenance of the drive.

Read the manual before working on the drive. You are expected to know the fundamentals of electricity, wiring, electrical components and electrical schematic symbols.

Categorization by frame size and option code

The frame size identifies information which concerns only a certain frame size of the drive. The frame size is shown on the type designation label. All frame sizes are listed in the technical data.

The option code (for example, option +E200) identifies information which concerns only a certain optional selection. The options included in the drive are listed on the type designation label.

Quick installation, commissioning and operation flowchart

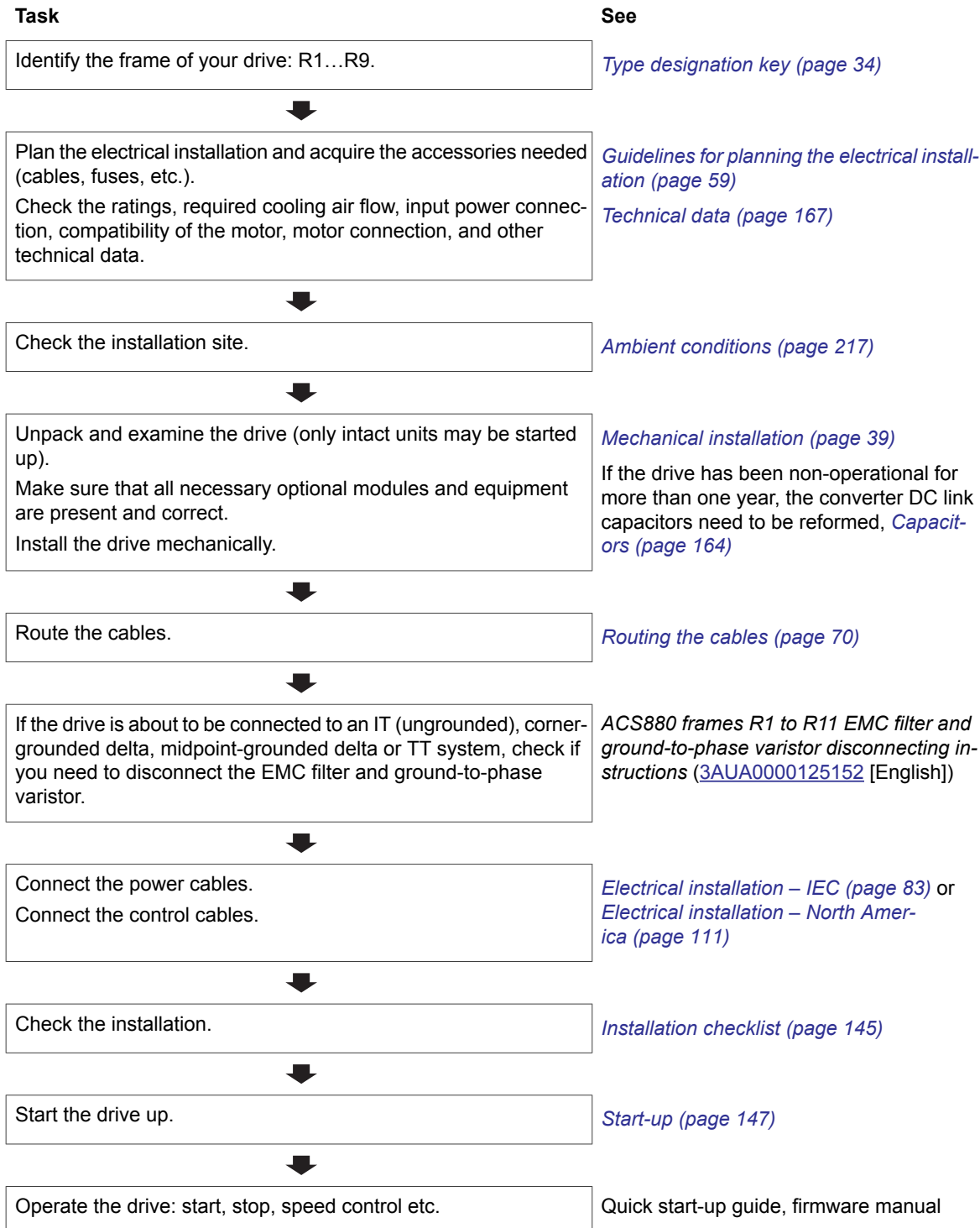

Terms and abbreviations

Term	Description
DC link	DC circuit between rectifier and inverter
DC link capacitors	Energy storage which stabilizes the intermediate circuit DC voltage
DPMP-01	Mounting platform for control panel (flush mounting)
DPMP-02	Mounting platform for control panel (surface mounting)

Term	Description
Drive	Frequency converter for controlling AC motors
EFB	Embedded fieldbus
EMC	Electromagnetic compatibility
EMI	Electromagnetic interference
EMT	Electrical metallic tubing, type of cable conduit
FAIO-01	Optional analog I/O extension module
FCAN	Optional CANopen® adapter module
FCNA-01	Optional ControlNet™ adapter module
FEN-01	Optional TTL incremental encoder interface module
FEN-11	Optional TTL absolute encoder interface module
FEN-21	Optional resolver interface module
FEN-31	Optional HTL incremental encoder interface module
FENA-21	Optional Ethernet adapter module for EtherNet/IP™, Modbus TCP® and PROFINET IO® protocols, 2-port
FEPL-02	Optional Ethernet POWERLINK adapter module
FIO-01	Optional digital I/O extension module
FIO-11	Optional analog I/O extension module
FMBT-21	Optional Ethernet adapter module for Modbus TCP protocol
FPBA-01	Optional PROFIBUS DP® adapter module
FPNO-21	Optional Profinet IO adapter module
FPTC-01	Optional thermistor protection module
FPTC-02	Optional ATEX-certified thermistor protection module for potentially explosive atmospheres
Frame, frame size	Physical size of the drive or power module
FSE-31	Optional pulse encoder interface module for safety encoder
FSO-21	Safety functions module which supports the FSE-31 module and the use of safety encoders
FSO-12	Safety functions module which does not support the use of encoders
FSPS-21	Optional functional safety module
IGBT	Insulated gate bipolar transistor
Inverter	Converts direct current and voltage to alternating current and voltage.
Parameter	In the drive control program, user-adjustable operation instruction to the drive, or signal measured or calculated by the drive. In some (for example fieldbus) contexts, a value that can be accessed as an object, eg, variable, constant, or signal.
PLC	Programmable logic controller
STO	Safe torque off (IEC/EN 61800-5-2)
ZCON	Type of control board
ZCU	Type of control unit
ZGAB	Brake chopper adapter board
ZGAD	Gate driver adapter board
ZINT	Main circuit board
ZMU	Type of memory unit, attached to the control unit

Related manuals

Name	Code (English)	Code (Translation)
Drive hardware manuals and guides		
<i>Drive/converter/inverter safety instructions</i>	Multilingual code: 3AXD50000037978	
<i>Drive modules cabinet design and construction instructions</i>	3AUA0000107668	

Name	Code (English)	Code (Translation)
ACS880-01 drives hardware manual	3AUA0000078093	
ACS880-01 quick installation guide for frames R1 to R3	3AUA0000085966	
ACS880-01 quick installation guide for frames R4 and R5	3AUA0000099663	
ACS880-01 quick installation guide for frames R6 to R9	3AUA0000099689	
ACS880...+P940 and +P944 drive modules supplement	3AUA0000145446	
ACS880-01 +N7502 drives for SynRM motors (0.8 to 200 kW) supplement	3AXD50000029482	
ACS880-01 assembly drawings for cable entry boxes of IP21 frames R5 to R9	3AUA0000119627	
ACS880-01, ACS580-01, ACH580-01, ACQ580-01 UK gland plate (+H358) installation guide	3AXD50000034735	
ACS880-01 drives and ACS880-04 drive modules common DC systems application guide	3AUA0000127818	
ACS880-01/04 +C132 marine type-approved drives supplement	3AXD50000010521	
ACx-AP-x Assistant control panels user's manual	3AUA0000085685	
Vibration dampers for ACS880-01 drives (frames R4 and R5, option +C131) installation guide	3AXD50000010497	
Vibration dampers for ACS880-01, ACS880-11 and ACS880-31 drives (frames R6 to R9, option +C131) installation guide	3AXD50000013389	
ACS880 frames R1 to R11 EMC filter and ground-to-phase varistor disconnecting instructions	3AUA0000125152	
ACS880-01...+C135 drives with flange mounting kit supplement	3AXD50000349814	
ACS880-01...+C135 frames R1 to R3 flange mounting kit quick installation guide	3AXD50000026158	
ACS880-01...+C135 frames R4 to R4 flange mounting kit quick installation guide	3AXD50000026159	
ACS880-01...+C135, ACS580-01...+C135, ACH580-01...+C135 and ACQ580-01...+C135 frames R6 to R9 flange mounting kit quick installation guide	3AXD50000019099	
Common mode filter kit for ACS880-01, ACS880-11 and ACS880-31 drives (frame R6, option +E208) installation instructions	3AXD50000015178	
Common mode filter kit for ACS880-01 frame R7, and for ACS880-11, ACS880-31, ACH580-31 and ACQ580-31 frame R8 (option +E208) installation instructions	3AXD50000015179	
Common mode filter kit for ACS880-01 drives (frame R9, option +E208) installation instructions	3AXD50000015201	
Converter modules capacitor reforming instructions	3BFE64059629	
ACS880-01 drives recycling instructions and environmental information	3AUA0000149383	
Drive firmware manuals and guides		
ACS880 primary control program firmware manual	3AUA0000085967	
Quick start-up guide for ACS880 drives with primary control program	3AUA0000098062	
Option manuals and guides		
Manuals and quick guides for I/O extension modules, fieldbus adapters, etc.		

See www.abb.com/drives/documents for all manuals on the Internet.

The code below opens an online listing of the manuals applicable to the product:

	ACS880-01 manuals
-----------------------------------------------------------------------------------	-----------------------------------

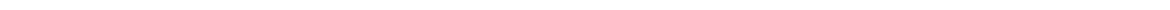



Operation principle and hardware description

Contents of this chapter

This chapter briefly describes the operation principle and construction of the drive.

Product overview

The ACS880-01 is a drive for controlling asynchronous AC induction motors, permanent magnet synchronous motors, AC induction servomotors and ABB synchronous reluctance motors (SynRM motors).

The main cooling air fan of the drive is speed controlled and the auxiliary cooling fan on/off controlled.

■ **Main circuit**

The main circuit of the drive is shown below.

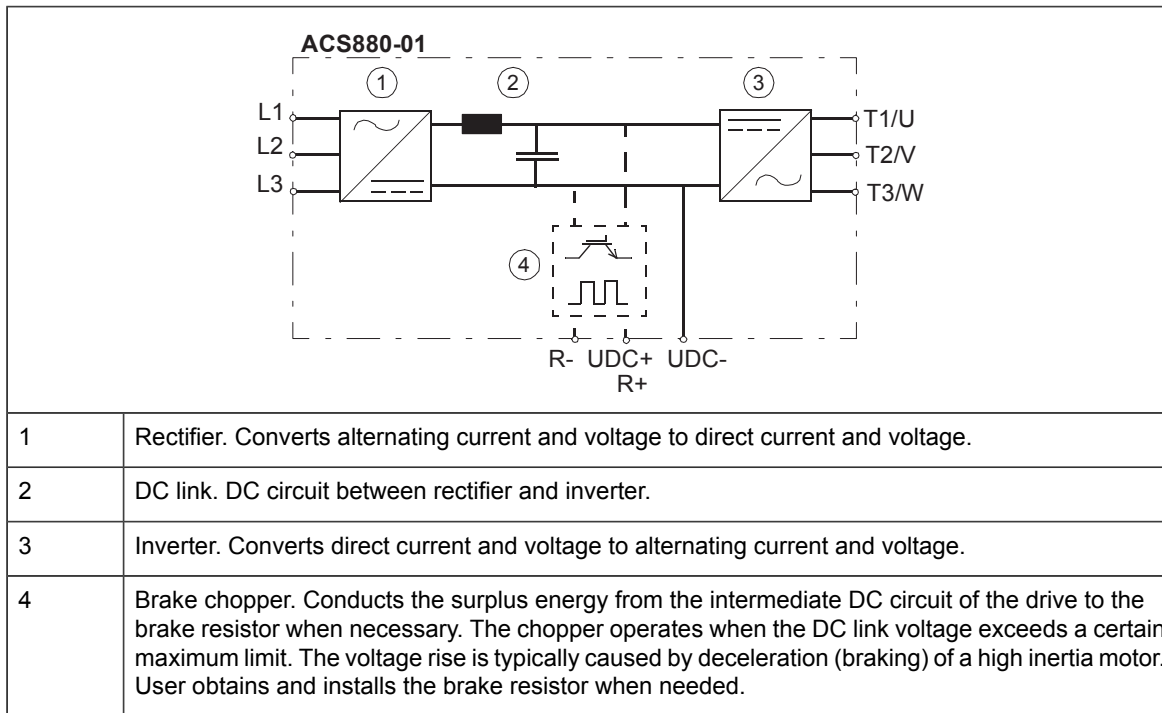

■ **Layout**

IP21, UL Type 1

The components of the drive are shown below (view of frame R5).

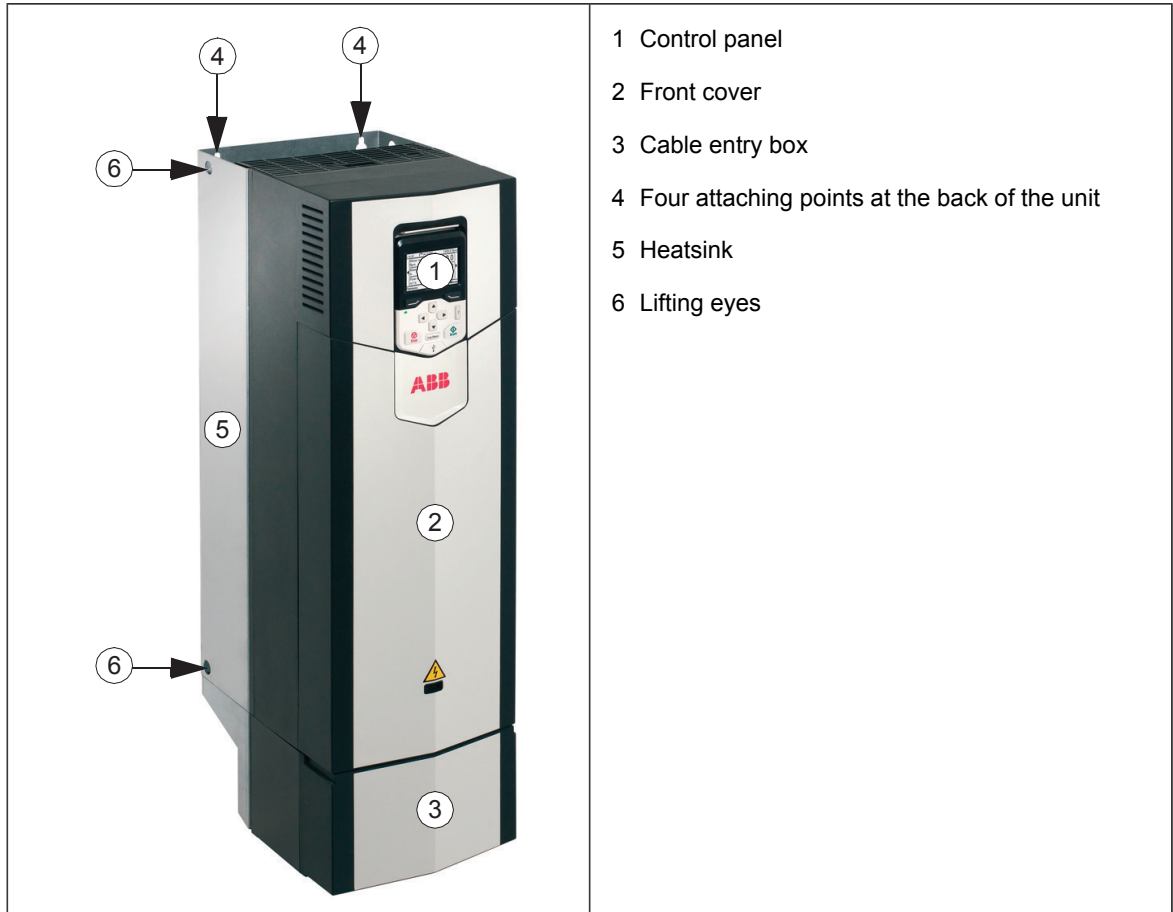

IP55 (option +B056)

The components of the IP55 drive (option +B056) are shown below (view of frame R4).



UL Type 12 (option +B056)

The components of the UL Type 12 drive (option +B056) are shown below (view of frame R6).



IP20 (UL Type Open, options +P940 and +P944)

See ACS880...+P940 and +P944 drive modules supplement ([3AUA0000145446](https://www.abb.com/3AUA0000145446) [English]).

■ Overview of power and control connections

This diagram shows the power connections and control interfaces of the drive.

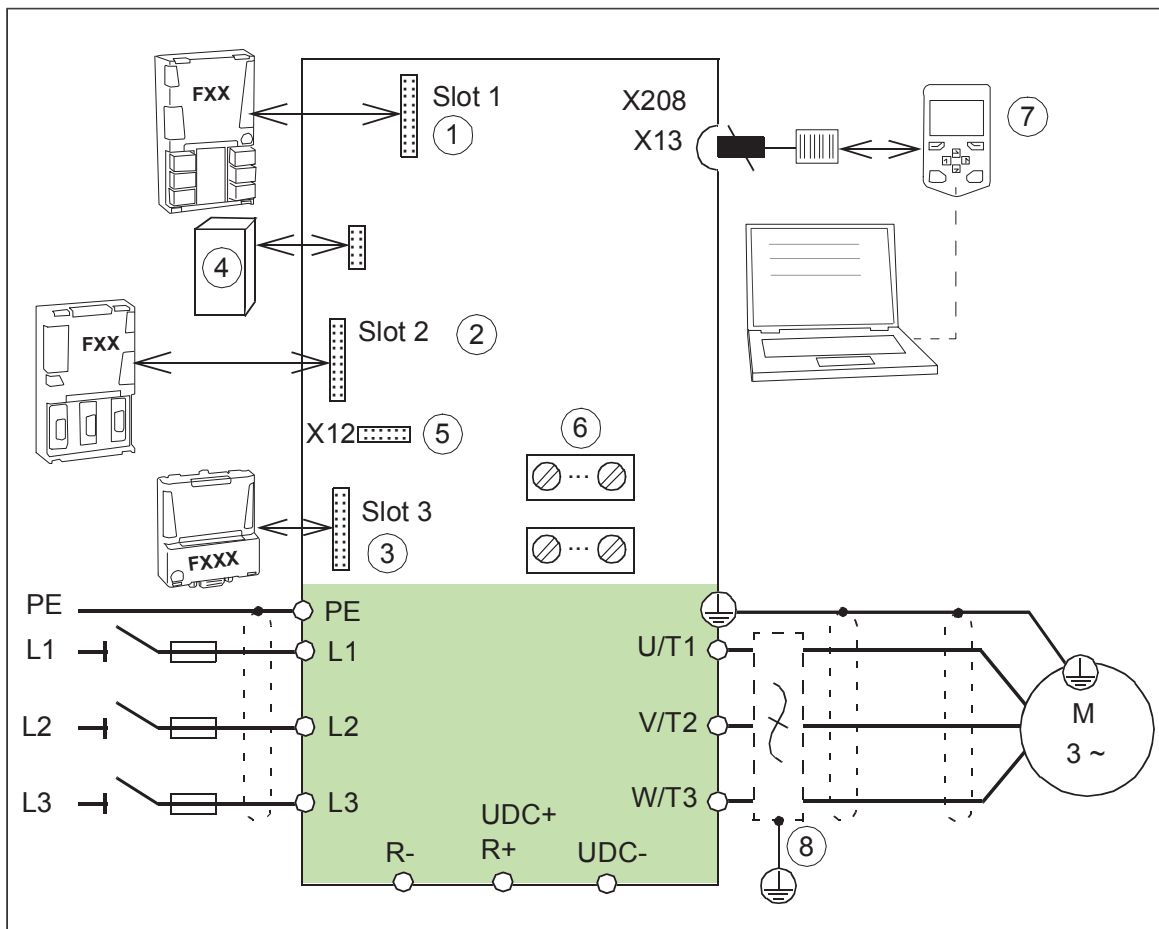

1, 2, 3	Analog and digital I/O extension modules, feedback interface modules and fieldbus communication modules can be inserted into slots 1, 2 and 3. See section <i>Type designation key (page 34)</i> .
4	Memory unit. See section <i>Control unit (page 165)</i> .
5	Connector for safety functions modules. See section <i>Installing FSO-xx safety functions modules (page 109)</i> .
6	I/O connections. See chapter <i>Control units of the drive (page 135)</i> .
7	Control panel. See section <i>Control panel (page 33)</i> .
8	du/dt, common mode or sine filter (optional). See chapter <i>Filters (page 273)</i> .

■ Control panel

The control panel can be removed by pulling it forward from the top edge and reinstalled in reverse order. For the use of the control panel, see the firmware manual or *ACx-AP-x Assistant control panels user's manual* ([3AUA0000085685](#) [English]).



Control panel mounting platform cover

In deliveries without control panel (option + 0J400) the control panel mounting platform is covered. The indication LEDs on the platform are visible through the protective cover. Note: The cover is not included with options +0J400+P940 and +0J400+P944.



Control panel door mounting kits

You can use a mounting platform to mount the control panel on the cabinet door. Mounting platforms for control panels are available as options from ABB. For more information, see

Manual	Code (English)
<i>DPMP-01 mounting platform for control panels installation guide</i>	3AUA0000100140
<i>DPMP-02/03 mounting platform for control panels installation guide</i>	3AUA0000136205
<i>DPMP-04 and DPMP-05 mounting platform for control panels installation guide</i>	3AXD50000308484
<i>DPMP-06 / 07 mounting platform for control panels installation guide</i>	3AXD50000289561

Type designation label

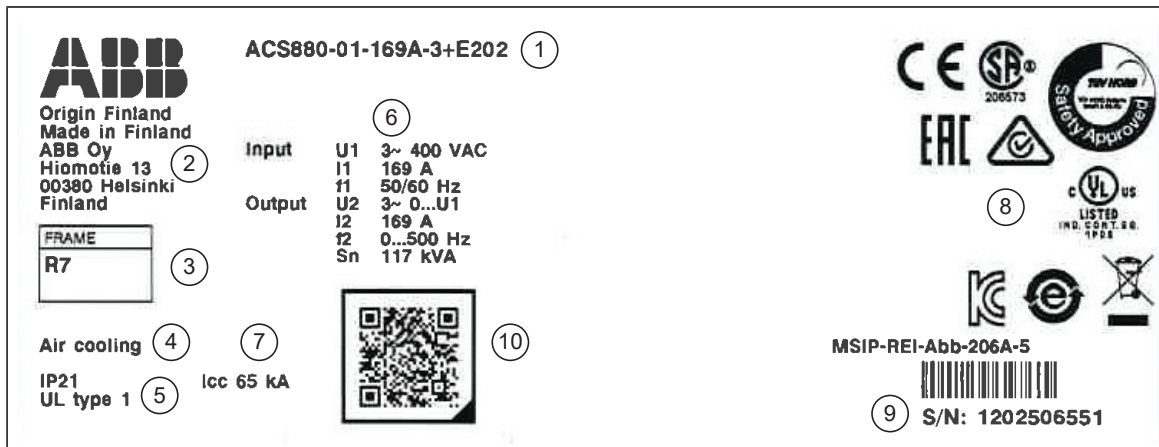

1	Type designation, see section Type designation key (page 34) .
2	Manufacturing address
3	Frame size
4	Cooling method
5	Degree of protection; UL/CSA specifications
6	Ratings in the supply voltage range, see section Ratings (page 167) .
7	Short-circuit withstand strength, see section Electrical power network specification (page 216) .
8	Valid markings
9	Serial number. The first digit of the serial number refers to the manufacturing plant. The next four digits refer to the unit's manufacturing year and week, respectively. The remaining digits complete the serial number so that there are no two units with the same number.
10	Link to product information

Type designation key

The type designation contains information on the specifications and configuration of the drive. The first digits from left express the basic drive type. The optional selections are given thereafter, separated by plus signs. The main selections are described below. Not all selections are available for all types. For more information, refer to the ordering instructions available separately on request.

Basic code

Code	Description
ACS880	Product series
Type	
ACS880-01-...	When no options are selected: Wall mounted drive, IP21 (UL Type 1), ACS-AP-W assistant control panel with Bluetooth connection, no EMC filter, DC choke, ACS880 primary control program, Safe torque off function, cable entry box, brake chopper in frames R1 to R4, coated boards, printed multilingual quick guides.
Size	

Code	Description
xxxx	See section <i>Ratings (page 167)</i> .
Voltage range	
2	208...240 V. This is indicated in the type designation label as typical input voltage level 3 ~ 230 V AC.
3	380...415 V. This is indicated in the type designation label as typical input voltage level 3 ~ 400 V AC.
5	380...500 V. This is indicated in the type designation label as typical input voltage levels 3 ~ 400/480/500 V AC.
7	525...690 V. This is indicated in the type designation label as typical input voltage levels 3 ~ 525/600/690 V AC.

■ Option codes

Code	Description
B056	IP55 (UL Type 12)
C131	Vibration dampers
C132	Marine type approval. Refer to <i>ACS880 +C132 marine type-approved cabinet-built drives supplement (3AXD50000039629 [English])</i> .
C135	Flange mounting
C205	Marine product certification issued by DNV GL
C206	Marine product certification issued by the American Bureau of Shipping (ABS)
C207	Marine product certification issued by Lloyd's Register (LR)
C208	Marine product certification issued by Registro Italiano Navale (RINA)
C209	Marine product certification issued by Bureau Veritas
C210	Marine product certification issued by Nippon Kaiji Kyokai (NK)
D150	Brake choppers
E200	EMC filter for 2nd environment TN (grounded) system, category C3
E201	EMC filter for second environment IT (ungrounded) system, category C3
E202	EMC filter for 1st environment TN (grounded) system, category C2
E208	Common mode filter
H358	Cable conduit entry (US/UK).
OJ400	No control panel
J425	ACS-AP-I control panel
K451	FDNA-01 DeviceNet™ adapter module
K454	FPBA-01 PROFIBUS DP adapter module
K457	FCAN-01 CANopen adapter module
K458	FSCA-01 RS-485 (Modbus/RTU) adapter module
K462	FCNA-01 ControlNet™ adapter module
K469	FECA-01 EtherCat adapter module
K470	FEPL-02 EtherPOWERLINK adapter module
K475	FENA-21 Ethernet adapter module for EtherNet/IP™, Modbus TCP and PROFINET IO protocols, 2-port
K490	FEIP-21 EtherNet/IP adapter module

36 Operation principle and hardware description

Code	Description
K491	FMBT-21 Modbus/TCP adapter module
K492	FPNO-21 PROFINET IO adapter module
L500	FIO-11 analog I/O extension module (1, 2 or 3 pcs)
L501	FIO-01 digital I/O extension module
L502	FEN-31 HTL incremental encoder interface module
L503	FDCO-01 optical DDCS communication adapter module
L508	FDCO-02 optical DDCS communication adapter module
L516	FEN-21 resolver interface module
L517	FEN-01 TTL incremental encoder interface module
L518	FEN-11 TTL absolute encoder interface module
L521	FSE-31 pulse encoder interface module
L525	FAIO-01 analog I/O extension module
L526	FDIO-01 digital I/O extension module
N5000	Winder control program
N5050	Crane control program
N5150	Centrifuge control program
N5200	PCP (Progressive Cavity Pump) control program
N5250	Rod pump control program
N5300	Test bench control program
N5350	Cooling tower control program
N5450	Override control program
N5500	Spinning and traverse control program
N5600	ESP (Electrical Submersible Pump) control program
N5650	Tower crane control program
N7502	Control program for synchronous reluctance motors (SynRM)
N8010	Drive application programming
P904	Extended warranty 24/30
P940	Version for cabinet mounting. (Drive without front cover and cable entry box. Includes panel holder, cable between panel holder and control unit, I/O clamp kit and main cable clamp kit in frames R1, R2 and R3, main cable clamp kit in frames R4, R5, R6, R7, R8 and R9. Cannot be selected with P944.)
P944	Version for cabinet mounting. (Drive without cable entry box. Cannot be selected with P940.)
Q971	ATEX-certified safe disconnection function
Q972	FSO-21 safety functions module
Q973	FSO-12 safety functions module
Q982	PROFIsafe with FSO-xx safety functions module and FENA-21 Ethernet adapter module
Q986	PROFIsafe safety functions module, FSPS-21
R700	English
R701	German
R702	Italian
R703	Dutch
R704	Danish
R705	Swedish

Code	Description
R706	Finnish
R707	French
R708	Spanish
R709	Portuguese
R711	Russian
R712	Chinese
R713	Polish
R714	Turkish

Note: Option codes R700...R714 denote full set of printed manuals in the selected language. The delivery can include manuals in English if the requested language is not available.



4

Mechanical installation

Contents of this chapter

This chapter tells how to check the installation site, unpack, check the delivery and install the drive mechanically.



Safety

**WARNING!**

For frame sizes R4 to R9: Use the lifting eyes of the drive when you lift the drive. Do not tilt the drive. The drive is heavy and its center of gravity is high. An overturning drive can cause physical injury.

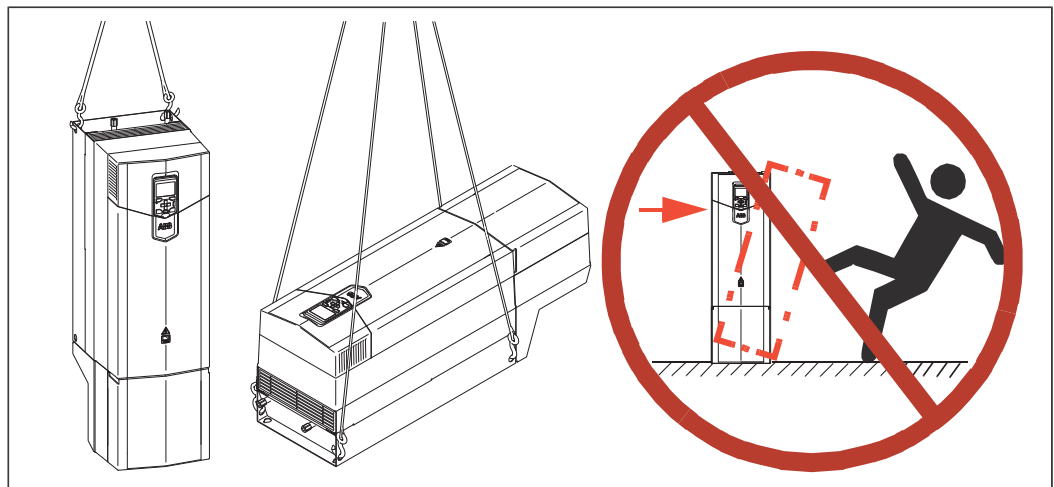

Mounting orientations

The drive must be installed in an upright position with the cooling section against a wall.

IP21 and IP55 frames R1 to R9 can be mounted side by side.

UL Type 1 frames R1 to R9 can be mounted side by side.

UL Type 12 frames R1 to R3 can be mounted side by side.

UL Type 12 frames R4 to R9 need 100 mm (4 in) between the hoods.

Note: Mounting the drives right next to each other side to side can make it difficult to read the serial number and rating information on the type designation label.

Required free space

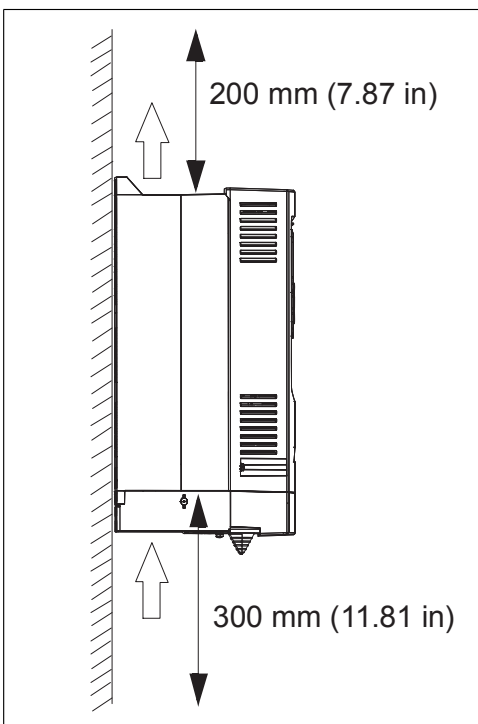

Examining the installation site

Make sure that the installation site agrees with these requirements:

The installation site has sufficient ventilation to remove heat from the drive. See section [Losses, cooling data and noise \(page 206\)](#).

The operation conditions of the drive agree with the specifications in section [Ambient conditions \(page 217\)](#).

The wall is vertical, not flammable and strong enough to hold the weight of the drive.

The material below the installation is not flammable.

There is enough free space above the drive (200 mm [7.87 in.]) and below the drive (300 mm [11.81 in.]) when measured from the drive base without the cable box) for cooling air flow, service and maintenance. There is enough free space in front of the drive for operation, service and maintenance.

Required tools

To install the drive mechanically, you need the following tools:

- drill with suitable bits
- screwdriver set (Torx, flat and/or Phillips, as appropriate)
- socket set (metric)
- tape measure, if you will not be using the provided mounting template.

Moving the drive

Move the transport package by pallet truck to the installation site.

Unpacking and examining the delivery

Examine that all items are present in the drive package and there are no signs of damage. Read the data on the type designation label of the drive to make sure that the drive is of the correct type.



Package of frames R1 to R5

IP21 (UL Type 1)

1	Drive with factory installed options. Control cable grounding shelf. Romex connectors in IP21 frames R1 to R3 in a plastic bag inside the cable box.	6...9	Cushions
2	-	10	Straps
3	Printed quick guides and manuals, multilingual residual voltage warning sticker	11	Top cardboard cover
4	Cardboard tray	12	Vibration damper package (option +C131) <u>Frame R4 and IP55 (UL Type 12) frame R5:</u> below the cable box <u>IP21 (UL Type 1) frame R5:</u> inside the cable box
5	Cardboard sleeve	-	-

To unpack:
 Cut the straps (10).
 Remove the top cardboard cover (11) and cushions (6...9).
 Lift the cardboard sleeve (5).
 Lift the drive.

IP55 (UL Type 12)

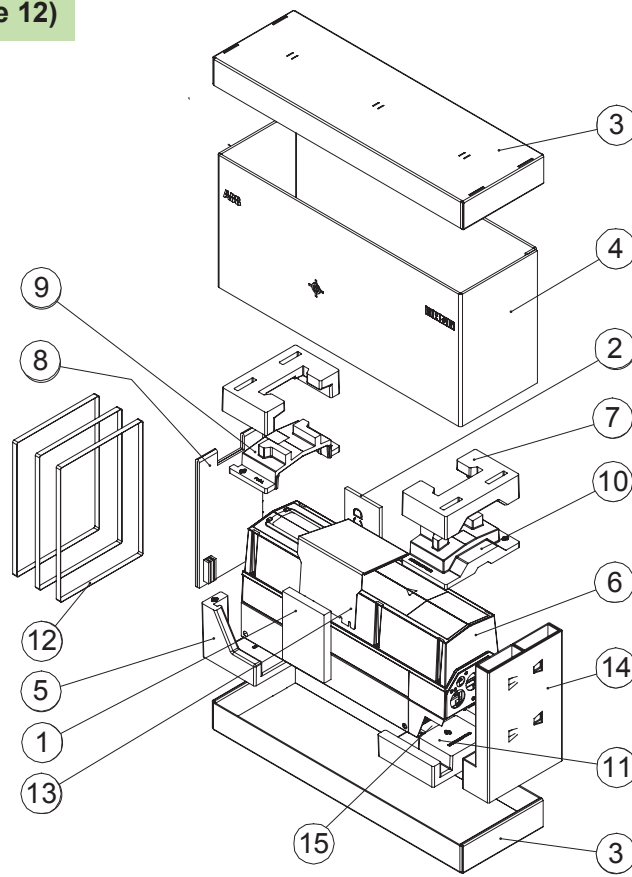

3AXD5000003341

1	Printed quick guides and manuals, multilingual residual voltage warning sticker	7...11	Cushions and cardboard support
2	-	12	Straps
3	Cardboard tray + top cardboard cover	13	Hood included in frames R4 and R5. The hood is required only in UL Type 12 installations.
4	Cardboard sleeve	14	Support
5	Cushion	15	Vibration damper package (option +C131)
6	Drive with factory installed options. Control cable grounding shelf.	-	-

To unpack:
 Cut the straps (12).
 Remove the top cardboard cover (3) and cushions (5, 7...11).
 Lift the cardboard sleeve (4).
 Lift the drive.

■ **Frame R5 cable box (IP21, UL Type 1)**

This illustration shows the contents of the cable box package. The package also includes an assembly drawing which shows how to install the cable entry box to the drive module frame.

44 Mechanical installation

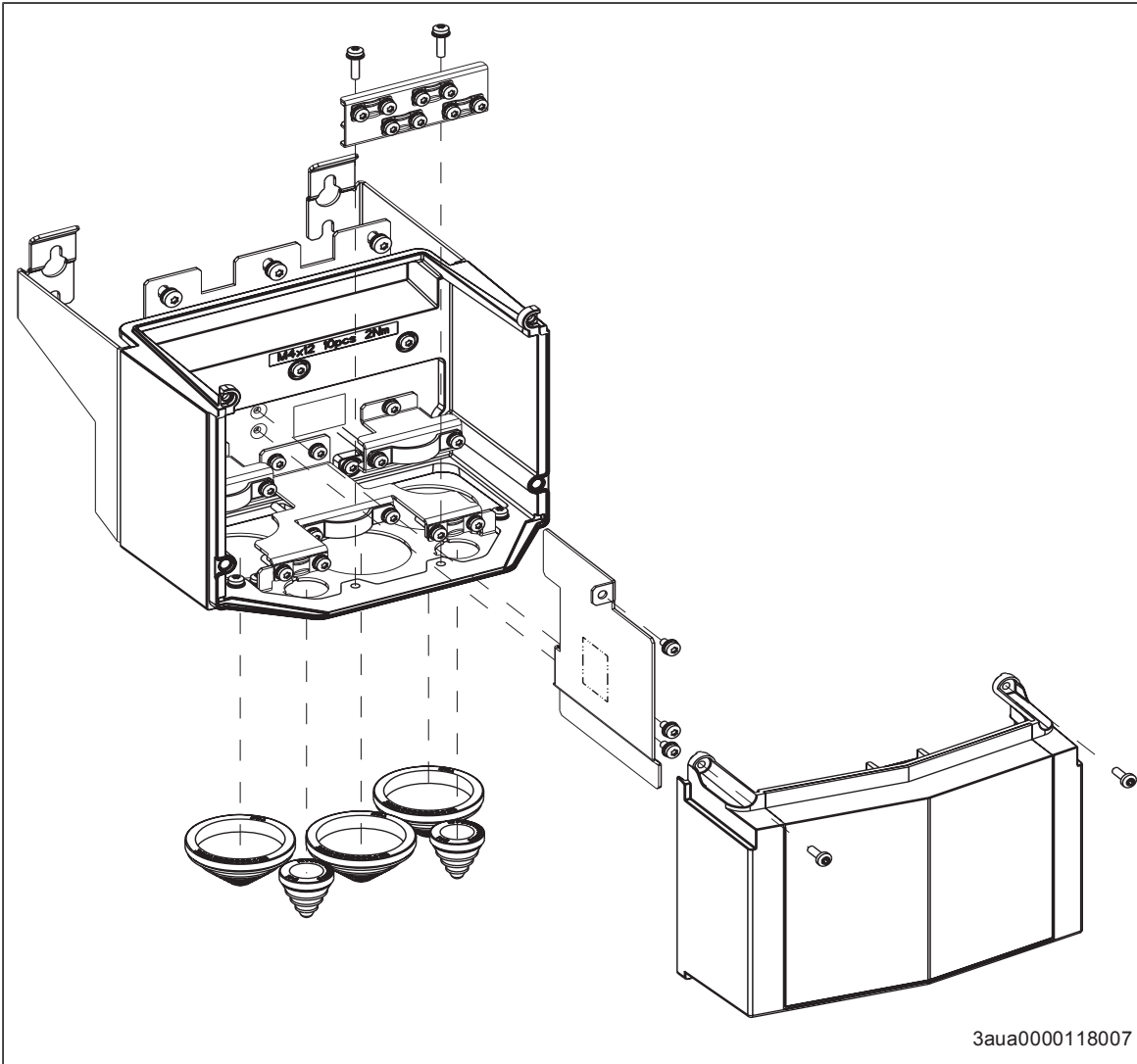

3aua0000118007

Package of frames R6 and R7

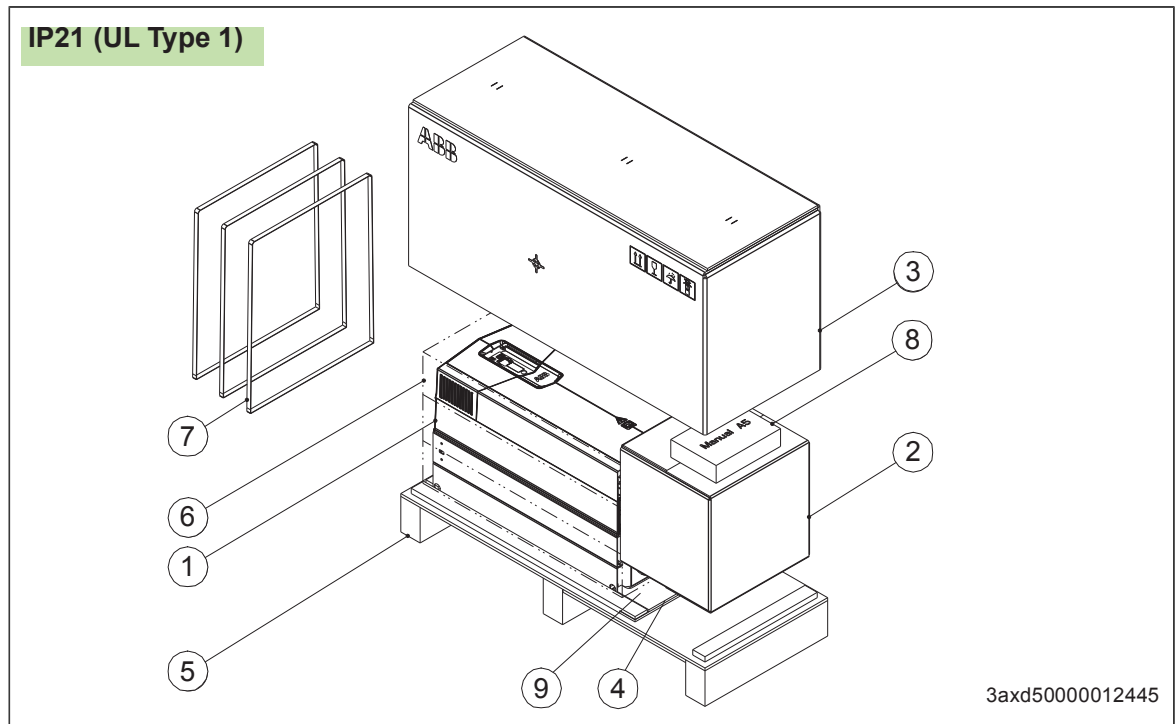

1	Drive with factory installed options	6	Cushions
2	Cable box. Power and control cable grounding shelves in a plastic bag, assembly drawing. Note: The cable entry box is mounted to the IP55 drive module frame at the factory	7	Straps
3	Cardboard cover	8	Printed quick guides and manuals and multi-lingual residual voltage warning sticker
4	Stopper	9	Vibration damper package (option +C131) <u>For frame R6:</u> inside the cable box.
5	Pallet tray	-	-

To unpack:

Cut the straps (7).

Remove the top cardboard cover (3) and cushion (6).

Attach lifting hooks to the lifting eyes of the drive. Lift the drive with a hoist.



IP55 (UL Type 12)

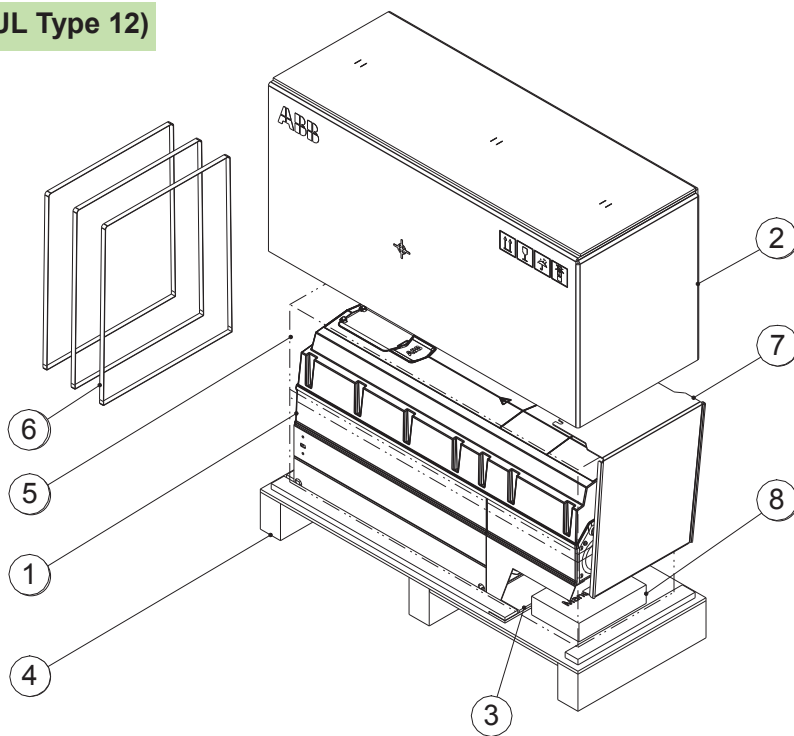

3axd50000012445

1	Drive with factory installed options	5	Cushions
2	Cardboard cover	6	Straps
3	Stopper	7	Hood (required only in UL Type 12 installation)
4	Pallet tray	8	Printed quick guides and manuals and multi-lingual residual voltage warning sticker

To unpack:

Cut the straps (6).

Remove the top cardboard cover (2) and cushion (5).

Attach lifting hooks to the lifting eyes of the drive. Lift the drive with a hoist.



■ **Frame R6 cable box (IP21, UL Type 1)**

This illustration shows the contents of the cable box package. The package also includes an assembly drawing which shows how to install the cable entry box to the drive module frame.

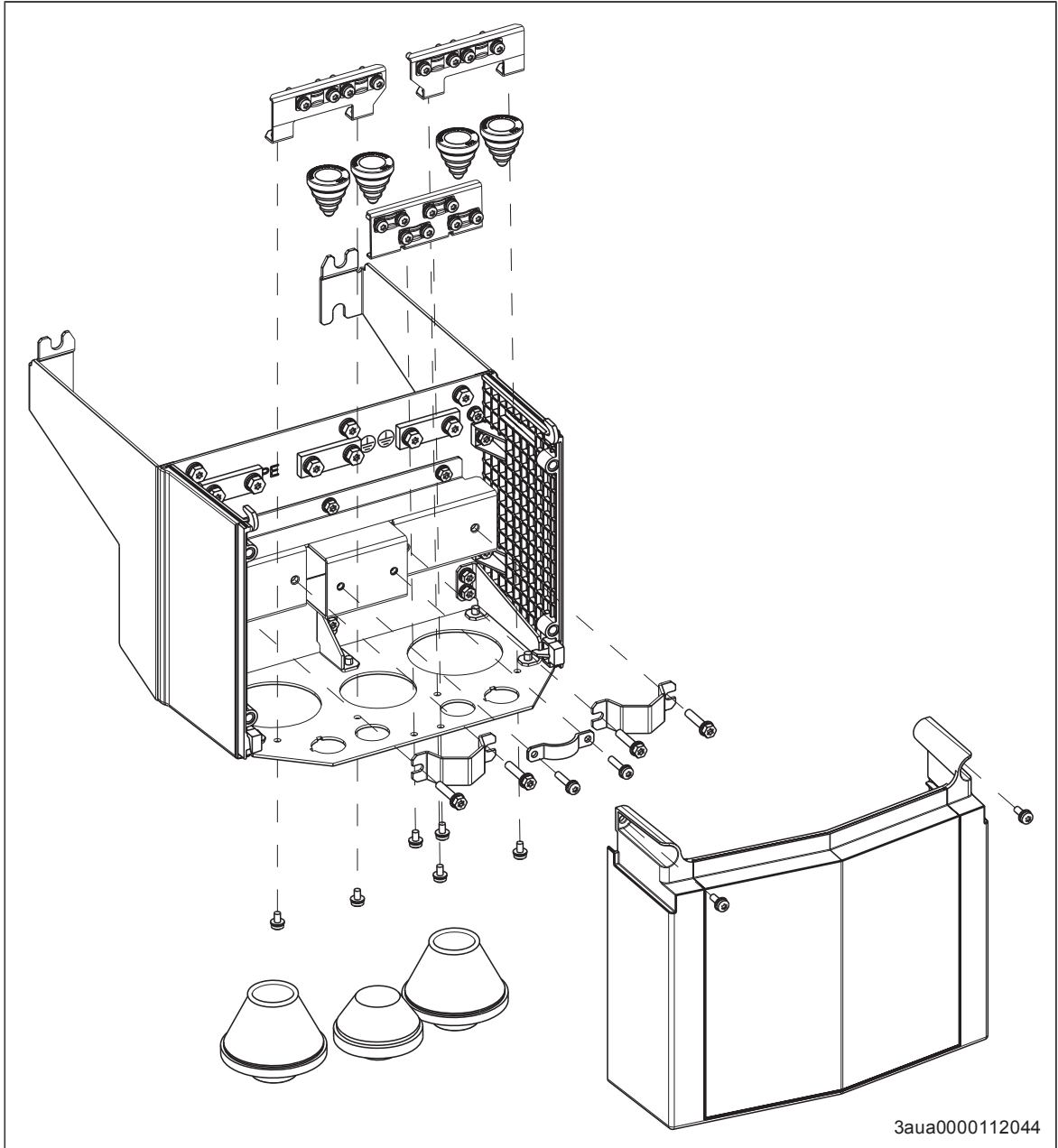

■ **Frame R7 cable box (IP21, UL Type 1)**

This illustration shows the contents of the cable box package. The package also includes an assembly drawing which shows how to install the cable entry box to the drive module frame.

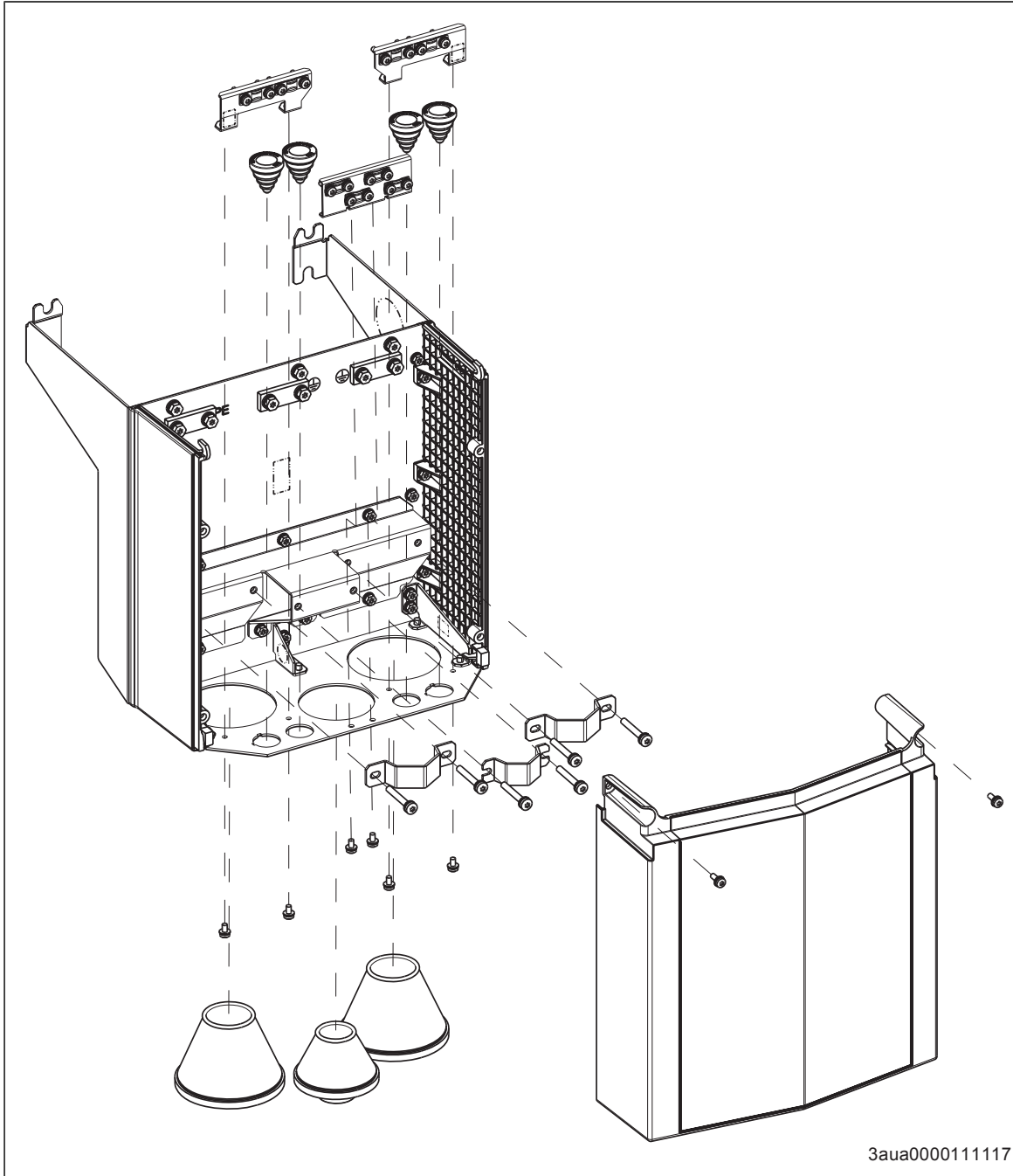

3aua0000111117

Package of frames R8 and R9

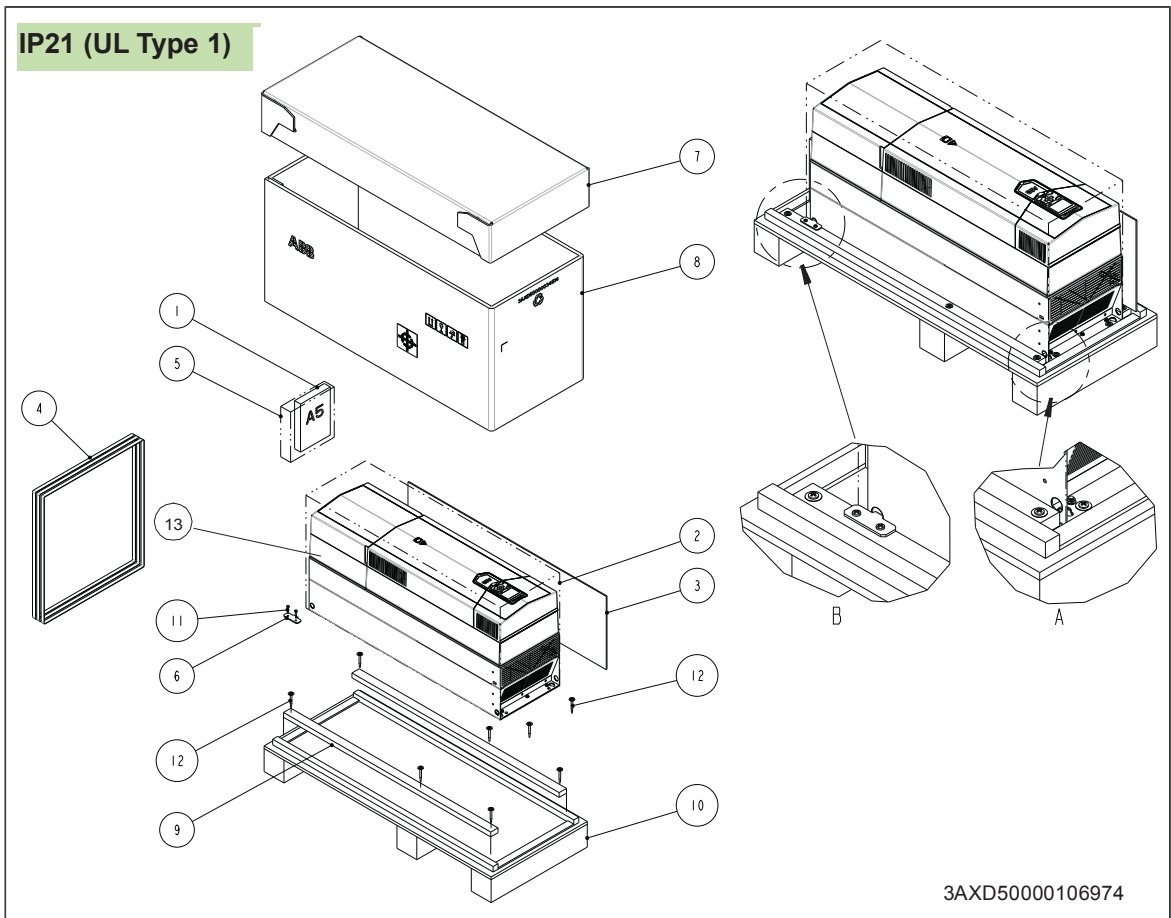

1	Printed quick guides and manuals and multi-lingual residual voltage warning sticker	7	Cardboard tray
2	VCI bag	8	Cardboard sleeve
3	Mounting template	9	Plywood support (not in R9)
4	Straps	10	Pallet tray
5	Plastic bag	11, 12	Screw
6	Packing bracket	13	Drive with factory installed options

To unpack:

Cut the straps (4).

Remove the tray (7) and cardboard sleeve (8).

Open the VCI bag (2).

Undo the attaching screws (a, b).

Lift the drive.



IP55 (UL Type 12)

3AXD50000106974

1	Printed quick guides and manuals and multi-lingual residual voltage warning sticker	9	Cardboard sleeve
2	VCI bag	10	Not included
3	Bubble wrap	11	Plywood support (not in R9)
4	Mounting template	12	Pallet tray
5	Straps	13	UL Type 12 hood
6	Plastic bag	14, 15	Screw
7	Packing bracket	16	Drive with factory installed options
8	Cardboard tray	-	-

To unpack:
 Cut the straps (5).
 Remove the tray (8) and cardboard sleeve (9).
 Remove the VCI bag (2).
 Undo the attaching screws (c, d).
 Lift the drive.



■ **Frame R8 cable box (IP21, UL Type 1)**

This illustration shows the contents of the cable box package. There is also an assembly drawing which shows how to install the cable entry box to the drive module frame.

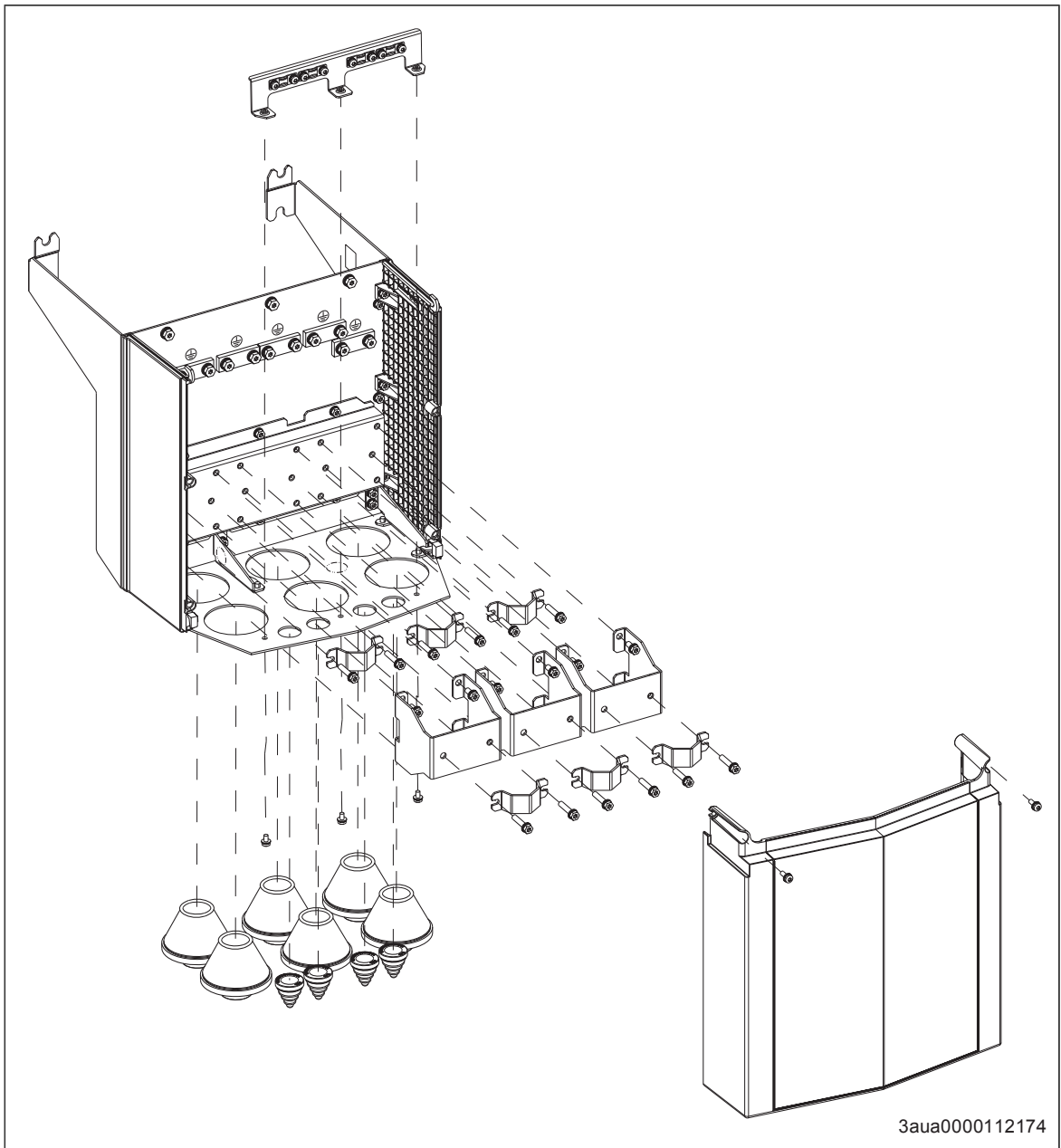

3aua0000112174

■ Frame R9 cable box (IP21, UL Type 1)

This illustration shows the contents of the cable box package. The package also includes an assembly drawing which shows how to install the cable entry box to the drive module frame.

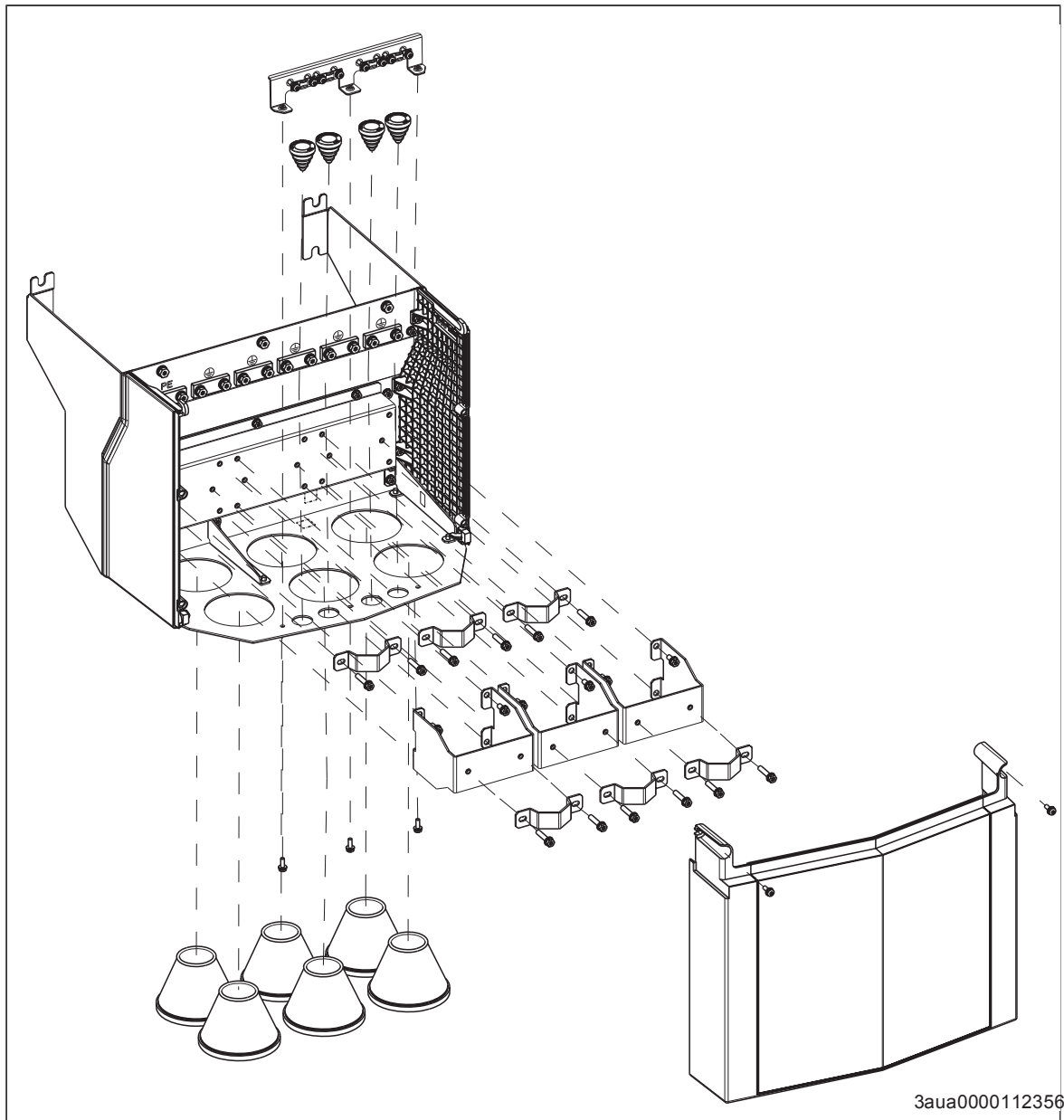

Installing the drive

This section tells you how to install the drive on wall without vibration dampers.

■ Vibration dampers (option +C131)

Marine type approval (option +C132) requires the installation of vibration dampers for frames R4 to R9 in wall installations. See *Vibration dampers for ACS880-01 drives (frames R4 and R5, option +C131) installation guide* ([3AXD50000010497](#) [English]) or *Vibration dampers for ACS880-01 drives (frames R6 to R9, option +C131) installation guide* ([3AXD50000010497](#) [English]). The guide is included in the vibration damper package.

■ Flange mounting (option +C135)

See:

Name	Code (English)
<i>ACS880-01...+C135 drives with flange mounting kit supplement</i>	3AXD50000349814
<i>ACS880-01...+C135 frames R1 to R3 flange mounting kit quick installation guide</i>	3AXD50000026158
<i>ACS880-01...+C135 frames R4 to R4 flange mounting kit quick installation guide</i>	3AXD50000026159
<i>ACS880-01...+C135, ACS580-01...+C135, ACH580-01...+C135 and ACQ580-01...+C135 frames R6 to R9 flange mounting kit quick installation guide</i>	3AXD50000019099

■ UK gland plate (option +H358)

See *ACS880-01, ACS580-01, ACH580-01, ACQ580-01 UK gland plate (+H358) installation guide* ([3AXD50000034735](#) [English]).

■ Cabinet installation (options +P940 and +P944)

See:

Name	Code (English)
<i>Drive modules cabinet design and construction instructions</i>	3AUA0000107668
<i>ACS880...+P940 and +P944 drive modules supplement</i>	3AUA0000145446



■ **Frames R1 to R4 (IP21, UL Type 1)**

1. See the dimensions in chapter *Dimension drawings*. Mark the locations for the four mounting holes.
2. Drill the mounting holes.
3. Insert anchors or plugs into the holes and start the screws or bolts into the anchors or plugs. Drive the screws or bolts long enough into the wall to make them carry the weight of the drive.
4. Position the drive onto the bolts on the wall.
5. Tighten the bolts in the wall securely.

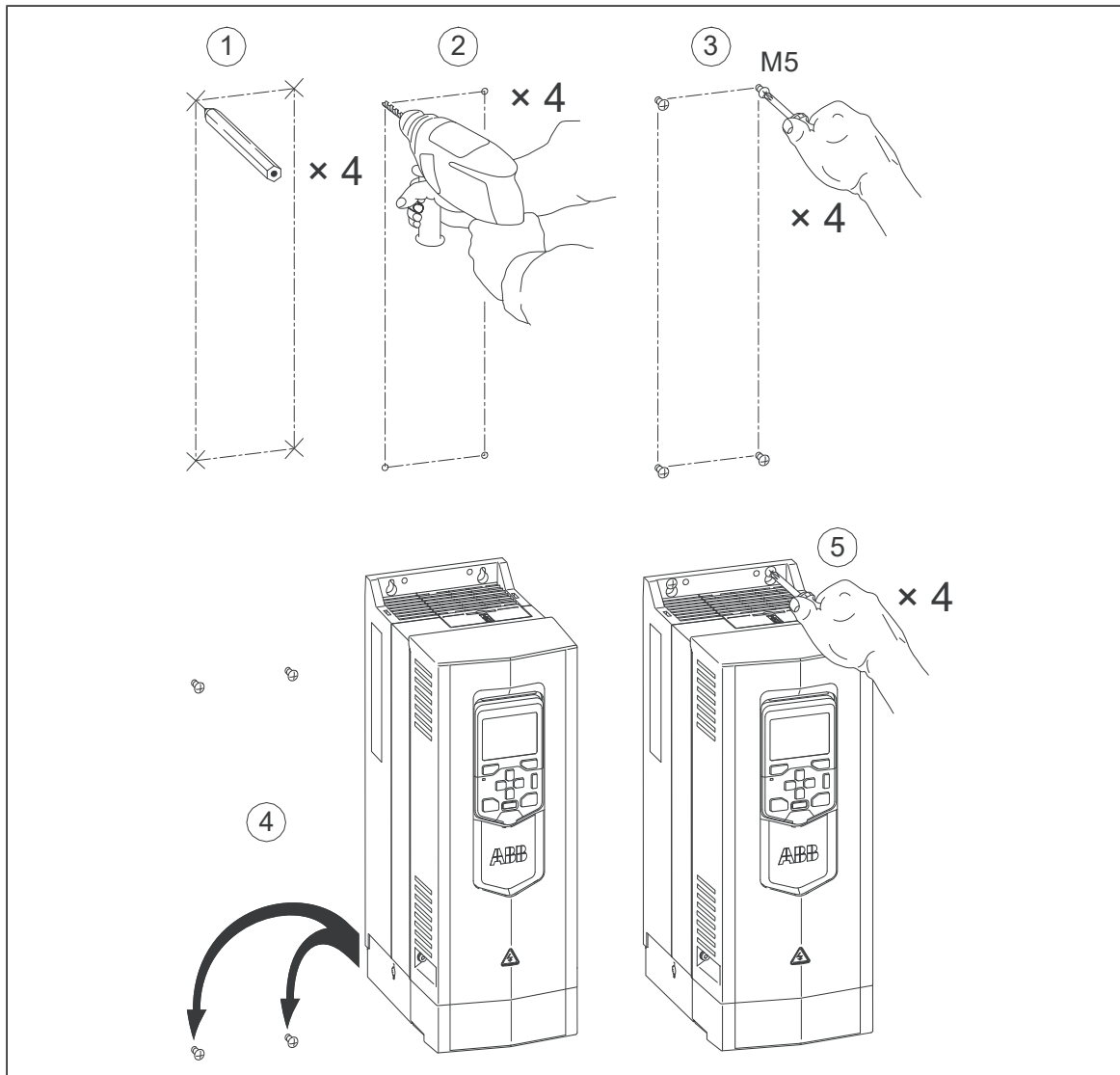

■ Frames R5 to R9 (IP21, UL Type 1)

1. See the dimensions in chapter *Dimension drawings*. Mark the locations for the four or six mounting holes.
Note: The lowest holes/mounting screws or bolts are not necessarily needed. If you use also them, you can replace the drive module without removing the cable entry box from the wall.
2. Drill the mounting holes.
3. Insert fixings anchors or plugs into the holes. Start the two upper bolts and the two lowest bolts into the anchors or plugs. Drive the bolts long enough into the wall to make them carry the weight of the drive.
4. Position the drive module onto the bolts on the wall.
5. Tighten the upper mounting bolts in the wall securely.
6. Remove the front cover.
7. Attach the cable box to the drive frame. For instructions, see the assembly drawing in the cable box. A view of frame R8 is shown below.
8. Tighten the lower mounting bolts in the wall securely.



56 Mechanical installation

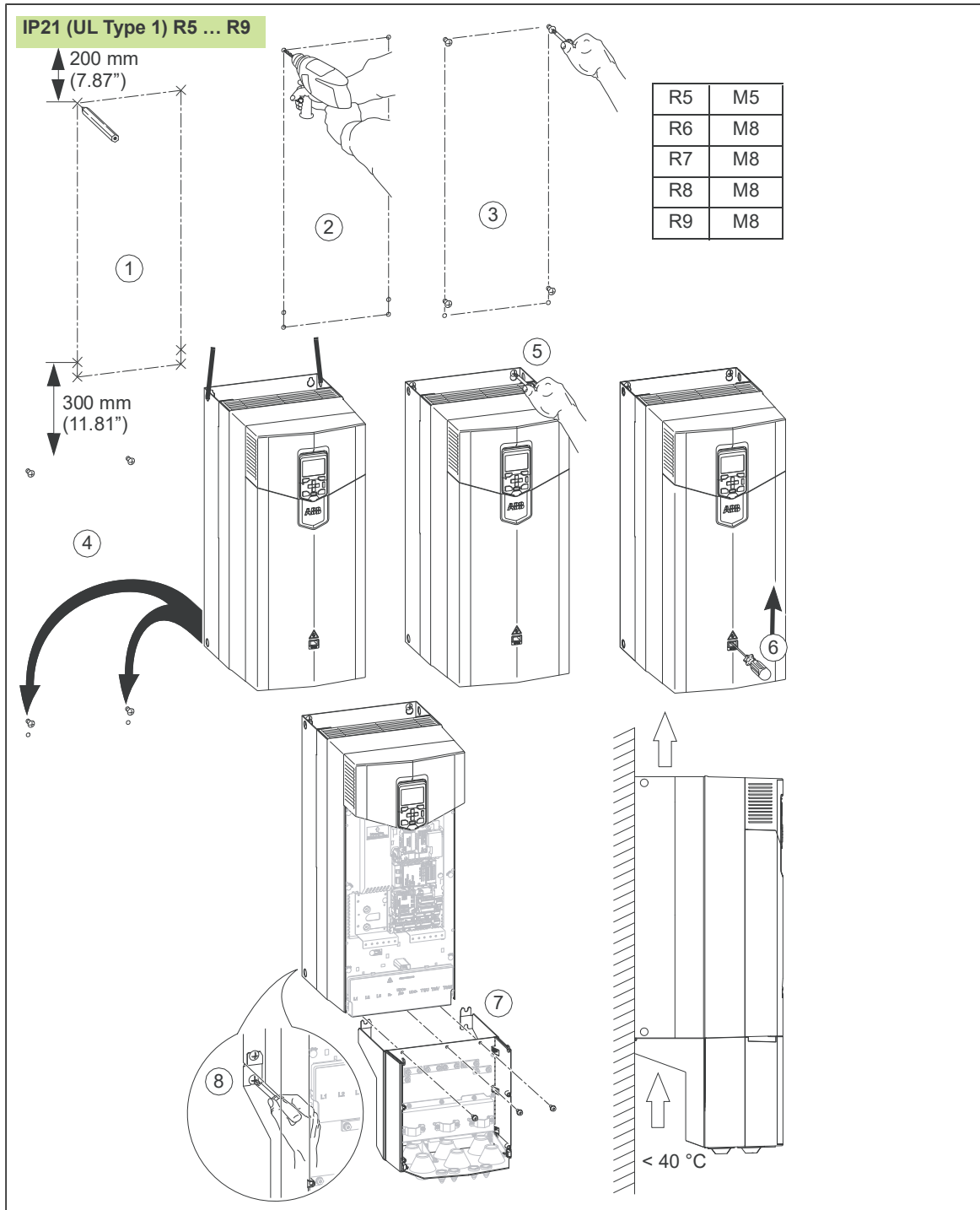

■ Frames R1 to R9 (IP55, UL Type 12)

Note: Do not open or remove the cable box for easier installation. The gaskets do not fulfill the degree of protection if the box is opened.

1. See the dimensions in chapter *Dimension drawings*. Mark the locations for the four or six mounting holes. The lowest holes are not necessarily needed.
2. Drill the mounting holes.
3. Insert fixings anchors or plugs into the holes.
4. Start the upper bolts into the mounting holes. Drive the bolts long enough into the wall to make them carry the weight of the drive.
5. Position the drive onto the upper bolts on the wall. Lift the drive with another person as it is heavy.
6. For UL Type 12 drives of frames R4 to R9: Put the hood onto the upper bolts.
7. Tighten the upper bolts in the wall securely.
8. Start the lower bolts into the mounting holes.
9. Tighten the lower bolts in the wall securely.



IP55 (UL Type 12) R1...R9

200 mm
(7.87")



①

300 mm
(11.81")

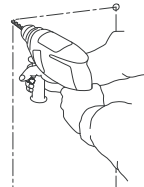

②

③

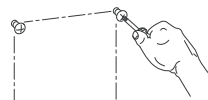

UL Type 12 (R4...R9)



⑥

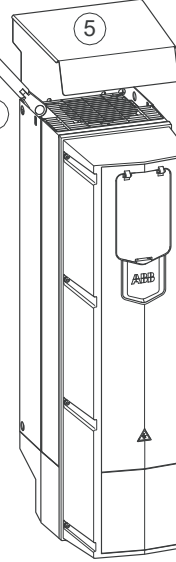

R1...R5	M5
R6...R9	M8



④

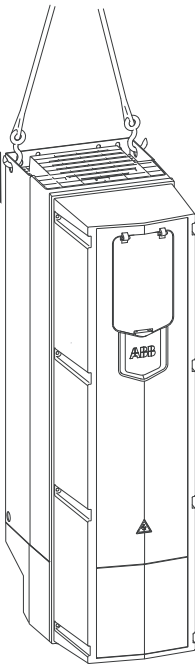

⑥

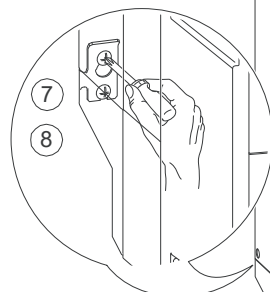
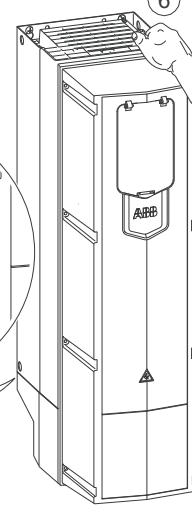

⑦

⑧



5

Guidelines for planning the electrical installation

Contents of this chapter

This chapter contains instructions for planning the electrical installation of the drive. Some instructions are mandatory to follow in every installation, others provide useful information that only concerns certain applications.

Limitation of liability

The installation must always be designed and made according to applicable local laws and regulations. ABB does not assume any liability whatsoever for any installation which breaches the local laws and/or other regulations. Furthermore, if the recommendations given by ABB are not followed, the drive may experience problems that the warranty does not cover.

Selecting the main supply disconnecting device

You must equip the drive with a main supply disconnecting device which meets the local safety regulations. You must be able to lock the disconnecting device to the open position for installation and maintenance work.

■ European Union

To meet the European Union Directives, according to standard EN 60204-1, Safety of Machinery, the disconnecting device must be one of the following types:

- switch-disconnector of utilization category AC-23B (IEC 60947-3)
 - disconnector that has an auxiliary contact that in all cases causes switching devices to break the load circuit before the opening of the main contacts of the disconnector (EN 60947-3)
 - a circuit-breaker suitable for isolation in accordance with IEC 60947-2.
-

■ North America

Installations must be compliant with NFPA 70 (NEC)¹⁾ and/or Canadian Electrical Code (CE) along with state and local codes for your location and application.

1) National Fire Protection Association 70 (National Electric Code).

■ Other regions

The disconnecting device must conform to the applicable local safety regulations.

Selecting the main contactor

You can equip the drive with a main contactor.

Follow these guidelines when you select a customer-defined main contactor:

- Dimension the contactor according to the nominal voltage and current of the drive. Also consider the environmental conditions such as surrounding air temperature.
- Select contactor with utilization category AC-1 (number of operations under load) according to IEC 60947-4, *Low-voltage switch gear and control gear*.
- Consider the application life time requirements.

Examining the compatibility of the motor and drive

Use asynchronous AC induction motors, permanent magnet synchronous motors, AC induction servomotors or ABB synchronous reluctance motors (SynRM motors) with the drive.

Select the motor size and drive type from the rating table on basis of the AC line voltage and motor load. You can find the rating table in the appropriate hardware manual. You can also use the DriveSize PC tool.

Make sure that the motor withstands the maximum peak voltage in the motor terminals. See [Requirements table \(page 61\)](#). For basics of protecting the motor insulation and bearings in drive systems, see [Protecting the motor insulation and bearings \(page 60\)](#).

Note:

- Consult the motor manufacturer before using a motor whose nominal voltage differs from the AC line voltage connected to the drive input.
- The voltage peaks at the motor terminals are relative to the supply voltage of the drive, not the drive output voltage.
- If the motor and drive are not of the same size, consider the operation limits of the drive control program for the motor nominal voltage and current. See the appropriate parameters in the firmware manual.

■ Protecting the motor insulation and bearings

The drive employs modern IGBT inverter technology. Regardless of frequency, the drive output comprises pulses of approximately the drive DC bus voltage with a very short rise time. The pulse voltage can almost double at the motor terminals, depending on the attenuation and reflection properties of the motor cable and the terminals. This can cause additional stress on the motor and motor cable insulation.

Modern variable speed drives with their fast rising voltage pulses and high switching frequencies can generate current pulses that flow through the motor bearings. This can gradually erode the bearing races and rolling elements.

du/dt filters protect motor insulation system and reduce bearing currents. Common mode filters mainly reduce bearing currents. Insulated N-end (non-drive end) bearings protect the motor bearings.

■ Requirements table

These tables show how to select the motor insulation system and when a drive du/dt and common mode filters and insulated N-end (non-drive end) motor bearings are required. Ignoring the requirements or improper installation may shorten motor life or damage the motor bearings and voids the warranty.

This table shows the requirements when an ABB motor is in use.

Motor type	Nominal AC supply voltage	Requirement for			
		Motor insulation system	ABB du/dt and common mode filters, insulated N-end motor bearings		
			$P_N < 100 \text{ kW}$ and frame size $< \text{IEC 315}$	$100 \text{ kW} \leq P_N < 350 \text{ kW}$ or $\text{IEC 315} \leq \text{frame size} < \text{IEC 400}$	$P_N \geq 350 \text{ kW}$ or frame size $\geq \text{IEC 400}$
$P_N < 134 \text{ hp}$ and frame size $< \text{NEMA 500}$	$134 \text{ hp} \leq P_N < 469 \text{ hp}$ or $\text{NEMA 500} \leq \text{frame size} \leq \text{NEMA 580}$	$P_N \geq 469 \text{ hp}$ or frame size $> \text{NEMA 580}$			
Random-wound M2_, M3_ and M4_	$U_N \leq 500 \text{ V}$	Standard	-	+ N	+ N + CMF
	$500 \text{ V} < U_N \leq 600 \text{ V}$	Standard	+ du/dt	+ N + du/dt	+ N + du/dt + CMF
		or	Reinforced	-	+ N
	$600 \text{ V} < U_N \leq 690 \text{ V}$ (cable length $\leq 150 \text{ m}$)	Reinforced	+ du/dt	+ N + du/dt	+ N + du/dt + CMF
		Reinforced	-	+ N	+ N + CMF
Form-wound HX_ and AM_	$380 \text{ V} < U_N \leq 690 \text{ V}$	Standard	n.a.	+ N + CMF	$P_N < 500 \text{ kW}$: +N + CMF
					$P_N \geq 500 \text{ kW}$: +N + du/dt + CMF
Old ¹⁾ form-wound HX_ and modular	$380 \text{ V} < U_N \leq 690 \text{ V}$	Check with the motor manufacturer.	+ N + du/dt with voltages over 500 V + CMF		
Random-wound HX_ and AM_ ²⁾	$0 \text{ V} < U_N \leq 500 \text{ V}$	Enamelled wire with fiber glass taping	+ N + CMF		
	$500 \text{ V} < U_N \leq 690 \text{ V}$		+ N + du/dt + CMF		
HDP	Consult the motor manufacturer.				

¹⁾ manufactured before 1.1.1998

²⁾ For motors manufactured before 1.1.1998, check for additional instructions with the motor manufacturer.

This table shows the requirements when a non-ABB motor is in use.

Motor type	Nominal AC supply voltage	Requirement for			
		Motor insulation system	ABB du/dt and common mode filters, insulated N-end motor bearings		
			$P_N < 100 \text{ kW}$ and frame size $< \text{IEC 315}$	$100 \text{ kW} \leq P_N < 350 \text{ kW}$ or $\text{IEC 315} \leq \text{frame size} < \text{IEC 400}$	$P_N \geq 350 \text{ kW}$ or frame size $\geq \text{IEC 400}$
$P_N < 134 \text{ hp}$ and frame size $< \text{NEMA 500}$	$134 \text{ hp} \leq P_N < 469 \text{ hp}$ or $\text{NEMA 500} \leq \text{frame size} \leq \text{NEMA 580}$	$P_N \geq 469 \text{ hp}$ or frame size $> \text{NEMA 580}$			
Random-wound and form-wound	$U_N \leq 420 \text{ V}$	Standard: $\hat{U}_{LL} = 1300 \text{ V}$	-	+ N or CMF	+ N + CMF
	$420 \text{ V} < U_N \leq 500 \text{ V}$	Standard: $\hat{U}_{LL} = 1300 \text{ V}$	+ du/dt	+ du/dt + (N or CMF)	+ N + du/dt + CMF
		or	Reinforced: $\hat{U}_{LL} = 1600 \text{ V}$, 0.2 micro-second rise time	-	+ N or CMF
	$500 \text{ V} < U_N \leq 600 \text{ V}$	Reinforced: $\hat{U}_{LL} = 1600 \text{ V}$	+ du/dt	+ du/dt + (N or CMF)	+ N + du/dt + CMF
		or	Reinforced: $\hat{U}_{LL} = 1800 \text{ V}$	-	+ N or CMF
	$600 \text{ V} < U_N \leq 690 \text{ V}$	Reinforced: $\hat{U}_{LL} = 1800 \text{ V}$	+ du/dt	+ du/dt + N	+ N + du/dt + CMF
		Reinforced: $\hat{U}_{LL} = 2000 \text{ V}$, 0.3 micro-second rise time ¹⁾	-	+ N + CMF	+ N + CMF

¹⁾ If the intermediate DC circuit voltage of the drive is increased from the nominal level due to long term resistor braking cycles, check with the motor manufacturer if additional output filters are needed in the applied drive operation range.

The abbreviations used in the tables are defined below.

Abbr.	Definition
U_N	Nominal AC line voltage
\hat{U}_{LL}	Peak line-to-line voltage at motor terminals which the motor insulation must withstand
P_N	Motor nominal power
du/dt	du/dt filter at the output of the drive
CMF	Common mode filter
N	N-end bearing: insulated motor non-drive end bearing
n.a.	Motors of this power range are not available as standard units. Consult the motor manufacturer.

Availability of du/dt filter and common mode filter by drive type

Product type	Availability of du/dt filter	Availability of common mode filter (CMF)
ACS880-01	Ordered separately, see chapter <i>Filters (page 273)</i>	Plus code option +E208

Additional requirements for explosion-safe (EX) motors

If you will use an explosion-safe (EX) motor, follow the rules in the requirements table above. In addition, consult the motor manufacturer for any further requirements.

Additional requirements for ABB motors of types other than M2_, M3_, M4_, HX_ and AM_

Use the selection criteria given for non-ABB motors.

Additional requirements for braking applications

When the motor brakes the machinery, the intermediate circuit DC voltage of the drive increases, the effect being similar to increasing the motor supply voltage by up to 20 percent. Consider this voltage increase when specifying the motor insulation requirements if the motor will be braking a large part of its operation time.

Example: Motor insulation requirement for a 400 V AC line voltage application must be selected as if the drive were supplied with 480 V.

Additional requirements for ABB high-output and IP23 motors

The rated output power of high output motors is higher than what is stated for the particular frame size in EN 50347 (2001).

This table shows the requirements for protecting the motor insulation and bearings in drive systems for ABB random-wound motor series (for example, M3AA, M3AP and M3BP).

Nominal AC supply voltage	Requirement for			
	Motor insulation system	ABB du/dt and common mode filters, insulated N-end motor bearings		
		$P_N < 100 \text{ kW}$	$100 \text{ kW} \leq P_N < 200 \text{ kW}$	$P_N \geq 200 \text{ kW}$
		$P_N < 140 \text{ hp}$	$140 \text{ hp} \leq P_N < 268 \text{ hp}$	$P_N \geq 268 \text{ hp}$
$U_N \leq 500 \text{ V}$	Standard	-	+ N	+ N + CMF
$500 \text{ V} < U_N \leq 600 \text{ V}$	Standard	+ du/dt	+ du/dt + N	+ du/dt + N + CMF
	or			
	Reinforced	-	+ N	+ N + CMF
$600 \text{ V} < U_N \leq 690 \text{ V}$	Reinforced	+ du/dt	+ du/dt + N	+ du/dt + N + CMF

Additional requirements for non-ABB high-output and IP23 motors

The rated output power of high-output motors is higher than what is stated for the particular frame size in EN 50347 (2001).

If you plan to use a non-ABB high-output motor or an IP23 motor, consider these additional requirements for protecting the motor insulation and bearings in drive systems:

- If motor power is below 350 kW: Equip the drive and/or motor with the filters and/or bearings according to the table below.
- If motor power is above 350 kW: Consult the motor manufacturer.

Nominal AC supply voltage	Requirement for		
	Motor insulation system	ABB du/dt and common mode filters, insulated N-end motor bearings	
		$P_N < 100 \text{ kW}$ or frame size $< \text{IEC 315}$	$100 \text{ kW} < P_N < 350 \text{ kW}$ or $\text{IEC 315} < \text{frame size} < \text{IEC 400}$
	$P_N < 134 \text{ hp}$ or frame size $< \text{NEMA 500}$	$134 \text{ hp} < P_N < 469 \text{ hp}$ or $\text{NEMA 500} < \text{frame size} < \text{NEMA 580}$	
$U_N \leq 420 \text{ V}$	Standard: $\hat{U}_{LL} = 1300 \text{ V}$	+ N or CMF	+ N or CMF
$420 \text{ V} < U_N < 500 \text{ V}$	Standard: $\hat{U}_{LL} = 1300 \text{ V}$	+ du/dt + (N or CMF)	+ N + du/dt + CMF
	or		
	Reinforced: $\hat{U}_{LL} = 1600 \text{ V}$, 0.2 microsecond rise time	+ N or CMF	+ N or CMF
$500 \text{ V} < U_N \leq 600 \text{ V}$	Reinforced: $\hat{U}_{LL} = 1600 \text{ V}$	+ du/dt + (N or CMF)	+ N + du/dt + CMF
	or		
	Reinforced: $\hat{U}_{LL} = 1800 \text{ V}$	+ N or CMF	+ N + CMF
$600 \text{ V} < U_N \leq 690 \text{ V}$	Reinforced: $\hat{U}_{LL} = 1800 \text{ V}$	+ N + du/dt	+ N + du/dt + CMF
	Reinforced: $\hat{U}_{LL} = 2000 \text{ V}$, 0.3 microsecond rise time ¹⁾	+ N + CMF	+ N + CMF

¹⁾ If the intermediate DC circuit voltage of the drive is increased from the nominal level due to long term resistor braking cycles, check with the motor manufacturer if additional output filters are needed in the applied drive operation range.

Additional data for calculating the rise time and the peak line-to-line voltage

The diagrams below show the relative peak line-to-line voltage and rate of change of voltage as a function of the motor cable length. If you need to calculate the actual peak voltage and voltage rise time considering the actual cable length, proceed as follows:

- Peak line-to line voltage: Read the relative \hat{U}_{LL}/U_N value from the diagram below and multiply it by the nominal supply voltage (U_N).
- Voltage rise time: Read the relative values \hat{U}_{LL}/U_N and $(du/dt)/U_N$ from the diagram below. Multiply the values by the nominal supply voltage (U_N) and substitute into equation $t = 0.8 \cdot \hat{U}_{LL}/(du/dt)$.

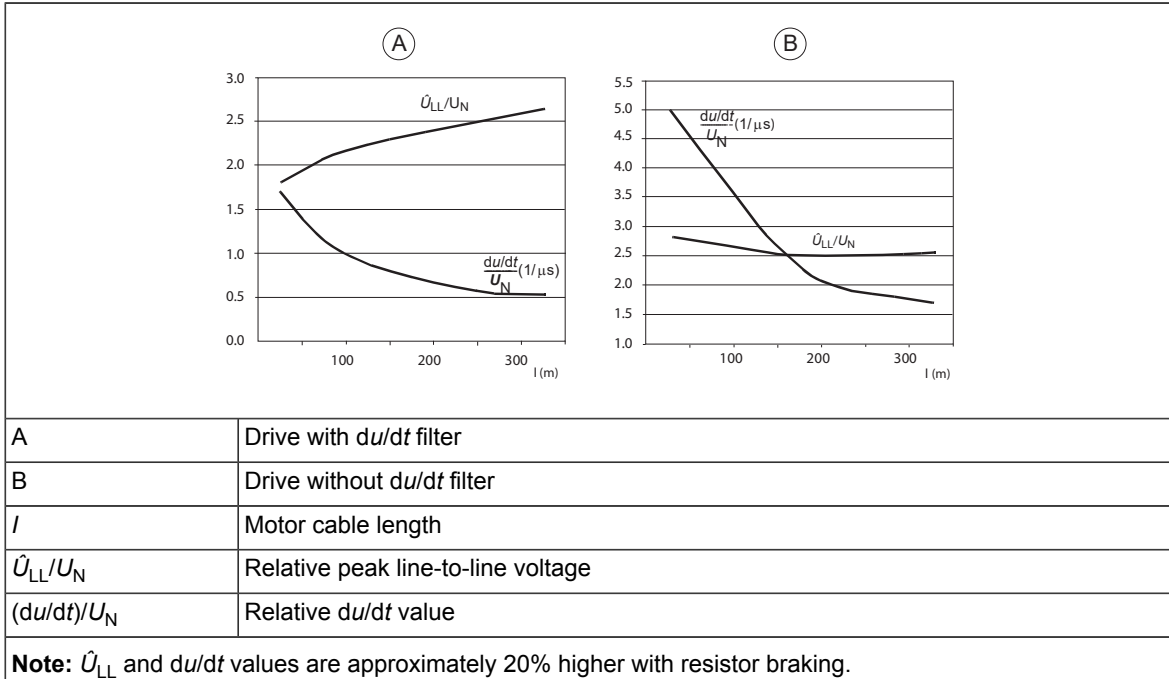

Additional note for sine filters

A sine filter also protects the motor insulation system. The peak phase-to-phase voltage with a sine filter is approximately $1.5 \cdot U_N$.

Selecting the power cables

■ General guidelines

Select the input power and motor cables according to local regulations.

- **Current:** Select a cable capable of carrying the maximum load current.
- **Temperature:** For an IEC installation, select a cable rated for at least 70 °C (158 °F) maximum permissible temperature of conductor in continuous use. For North America, select a cable rated for at least 75 °C (167 °F). Exception: For a drive with enclosure class IP55 [UL Type 12] (option +B056), select a 90 °C (194 °F) cable.
- **Voltage:** 600 V AC cable is accepted for up to 500 V AC. 750 V AC cable is accepted for up to 600 V AC. 1000 V AC cable is accepted for up to 690 V AC.

To comply with the EMC requirements of the CE mark, use one of the preferred cable types. See [Preferred power cable types \(page 66\)](#).

Symmetrical shielded cable reduces electromagnetic emission of the whole drive system as well as the stress on motor insulation, bearing currents and wear.

Metal conduit reduces electromagnetic emission of the whole drive system.

The protective conductor must always have an adequate conductivity.

Unless local wiring regulations state otherwise, the cross-sectional area of the protective conductor must agree with the conditions that require automatic disconnection of the supply required in 411.3.2. of IEC 60364-4-41:2005 and be capable of withstanding the prospective fault current during the disconnection time of the protective device. The cross-sectional area of the protective conductor can either be selected from the table below or calculated according to 543.1 of IEC 60364-5-54.

This table shows the minimum cross-sectional area of the protective conductor related to the phase conductor size according to IEC/UL 61800-5-1 when the phase conductor and the protective conductor are made of the same metal. If this is not so, the cross-sectional area of the protective grounding conductor shall be determined in a manner which produces a conductance equivalent to that which results from the application of this table.

Cross-sectional area of the phase conductors S (mm ²)	Minimum cross-sectional area of the corresponding protective conductor S _p (mm ²)
S ≤ 16	S ¹⁾
16 < S ≤ 35	16
35 < S	S/2

1) To comply with standard IEC/EN 61800-5-1 (UL 61800-5-1)

- use a protective earth conductor with a minimum cross-sectional area of 10 mm² Cu or 16 mm² Al (as an alternative when aluminum cables are permitted),
or
- use a second protective earth conductor of the same cross-sectional area as the original protective earth conductor,
or
- use a device that automatically disconnects the supply if the protective earth conductor is damaged.

If the protective earth conductor is separate (that is, it does not form part of the input power cable or the input power cable enclosure), the minimum cross-sectional area must be:

- 2.5 mm² when the conductor is mechanically protected,
or
- 4 mm² when the conductor is not mechanically protected.

■ Typical power cable sizes

See the technical data.

■ Power cable types

Preferred power cable types



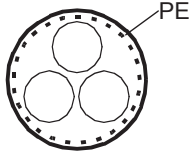
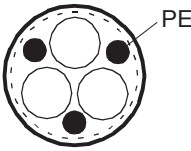

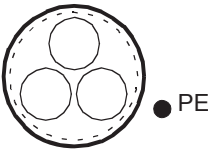
This section presents the preferred cable types. Make sure that the selected cable type also complies with local/state/country electrical codes.

Cable type	Use as input power cabling	Use as motor cabling
 <p>Symmetrical shielded (or armored) cable with three phase conductors and concentric PE conductor as shield (or armor)</p>	Yes	Yes
 <p>Symmetrical shielded (or armored) cable with three phase conductors and symmetrically constructed PE conductor and a shield (or armor)</p>	Yes	Yes

Cable type	Use as input power cabling	Use as motor cabling
 <p>Symmetrical shielded (or armored) cable with three phase conductors and a shield (or armor), and separate PE conductor/cable ¹⁾</p>	Yes	Yes

¹⁾ A separate PE conductor is required if the conductivity of the shield (or armor) is not sufficient for the PE use.

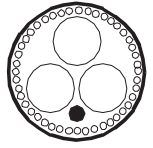
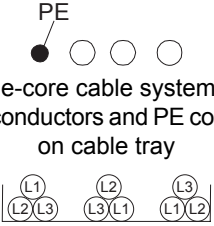
Alternate power cable types

Cable type	Use as input power cabling	Use as motor cabling
 <p>Four-conductor cabling in PVC conduit or jacket (three phase conductors and PE)</p>	Yes with phase conductor smaller than 10 mm ² (8 AWG) Cu.	Yes with phase conductor smaller than 10 mm ² (8 AWG) Cu, or motors up to 30 kW (40 hp). Note: Shielded or armored cable, or cabling in metal conduit is always recommended to minimize radio frequency interference.
 <p>Four-conductor cabling in metal conduit (three phase conductors and PE), eg, EMT, or four-conductor armored cable</p>	Yes	Yes with phase conductor smaller than 10 mm ² (8 AWG) Cu, or motors up to 30 kW (40 hp)
 <p>Well-shielded (Al/Cu shield or armor) four-conductor cable (three phase conductors and a PE)</p>	Yes	Yes with motors up to 100 kW (135 hp). A potential equalization between the frames of motor and driven equipment is required.
 <p>A single-core cable system: three phase conductors and PE conductor on cable tray</p> <p>Preferable cable arrangement to avoid voltage or current unbalance between the phases</p>	<p>Yes</p>  <p>WARNING! If you use unshielded single-core cables in an IT network, make sure that the non-conductive outer sheath (jacket) of the cables have good contact with a properly grounded conductive surface. For example, install the cables on a properly grounded cable tray. Otherwise voltage may become present on the non-conductive outer sheath of the cables, and there is even a risk of an electric shock.</p>	No

Not allowed power cable types

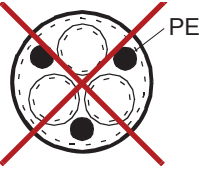
Cable type	Use as input power cabling	Use as motor cabling
 <p>Symmetrical shielded cable with individual shields for each phase conductor</p>	No	No

■ Additional guidelines, North America

ABB recommends the use of conduit for power wiring to the drive and between the drive and the motor(s). Due to the variety of application needs, metallic and non-metallic conduit can be used. ABB recommends the use of metallic conduit.

The following table shows examples of various materials and methods for wiring the drive in the intended application. See NEC 70 along with state and local codes for the appropriate materials for your application.

In all applications, ABB prefers the use of symmetrical shielded VFD cable between drive and motor(s).

Wiring method	Notes
Conduit - Metallic ^{1) 2)}	
Electrical metallic tubing: Type EMT	Prefer symmetrical shielded VFD cable.
Rigid metal conduit: Type RMC	Use separate conduit run for each motor.
Liquid-tight flexible metal electrical conduit: Type LFMC	Do not run input power wiring and motor wiring in the same conduit.
Conduit - Non-metallic ^{2) 3)}	
Liquid-tight flexible non-metallic conduit: Type LFNC	Prefer symmetrical shielded VFD cable. Use separate conduit run for each motor. Do not run input power wiring and motor wiring in the same conduit.
Wireways ²⁾	
Metallic	Prefer symmetrical shielded VFD cable. Separate motor wiring from input power wiring and other low voltage wiring. Do not run outputs of multiple drives parallel. Bundle each cable (wiring) together and use separators where possible.
Free air ²⁾	
Enclosures, air handlers, etc.	Prefer symmetrical shielded VFD cable. Allowed internally in enclosures when in accordance with UL.

¹⁾ Metallic conduit may be used as an additional ground path, provided this path is a solid path capable of handling ground currents.

²⁾ See NFPA NEC 70, UL, and local codes for your application.

³⁾ Non-metallic conduit use underground is allowed; however, these installations inherently have an increased chance for nuisance problems due to the potential for water/moisture in the conduit. Water/moisture in the conduit increases the likelihood of VFD faults or warnings. Proper installation is required to make sure there is no intrusion of water/moisture.

Metal conduit

Couple separate parts of a metal conduit together: bridge the joints with a ground conductor bonded to the conduit on each side of the joint. Also bond the conduits to the drive enclosure and motor frame. Use separate conduits for input power, motor, brake resistor, and control wiring. Do not run motor wiring from more than one drive in the same conduit.

■ Power cable shield

If the cable shield is used as the sole protective earth (PE) conductor, make sure that its conductivity agrees with the PE conductor requirements.

To effectively suppress radiated and conducted radio-frequency emissions, the cable shield conductivity must be at least 1/10 of the phase conductor conductivity. The requirements are easily met with a copper or aluminum shield. The minimum requirement of the motor cable shield of the drive is shown below. It consists of a concentric layer of copper wires with an open helix of copper tape or copper wire. The better and tighter the shield, the lower the emission level and bearing currents.

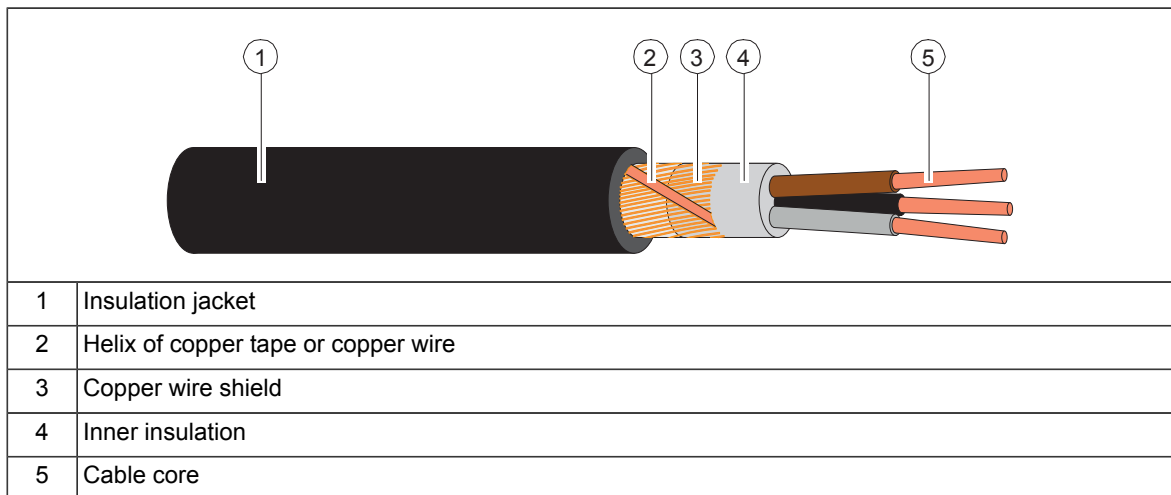

Selecting the control cables

■ Shielding

Only use shielded control cables.

Use a double-shielded twisted pair cable for analog signals. This type of cable is recommended for the pulse encoder signals also. Use one individually shielded pair for each signal. Do not use common return for different analog signals.

A double-shielded cable (a) is the best alternative for low-voltage digital signals, but single-shielded (b) twisted pair cable is also acceptable.

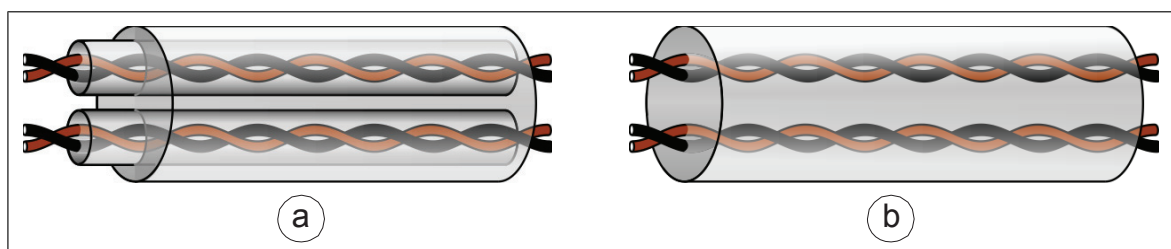

■ Signals in separate cables

Run analog and digital signals in separate, shielded cables. Do not mix 24 V DC and 115/230 V AC signals in the same cable.

■ Signals that can be run in the same cable

If their voltage does not exceed 48 V, relay-controlled signals can be run in the same cables as digital input signals. The relay-controlled signals should be run as twisted pairs.

■ Relay cable

The cable type with braided metallic shield (for example ÖLFLEX by LAPPKABEL, Germany) has been tested and approved by ABB.

■ Control panel to drive cable

Use EIA-485 with male RJ-45 connector, cable type Cat 5e or better. The maximum permitted length of the cable is 100 m (328 ft).

■ PC tool cable

Connect the Drive composer PC tool to the drive through the USB port of the control panel. Use a USB Type A (PC) - Type Mini-B (control panel) cable. The maximum length of the cable is 3 m (9.8 ft).

Routing the cables

■ General guidelines – IEC

- Route the motor cable away from other cables. Motor cables of several drives can be run in parallel installed next to each other.
- Install the motor cable, input power cable and control cables on separate trays.
- Avoid long parallel runs of motor cables with other cables.
- Where control cables must cross power cables, make sure that they are arranged at an angle as near to 90 degrees as possible.
- Do not run extra cables through the drive.
- Make sure that the cable trays have good electrical bonding to each other and to the grounding electrodes. Aluminum tray systems can be used to improve local equalizing of potential.

The following figure illustrates the cable routing guidelines with an example drive.

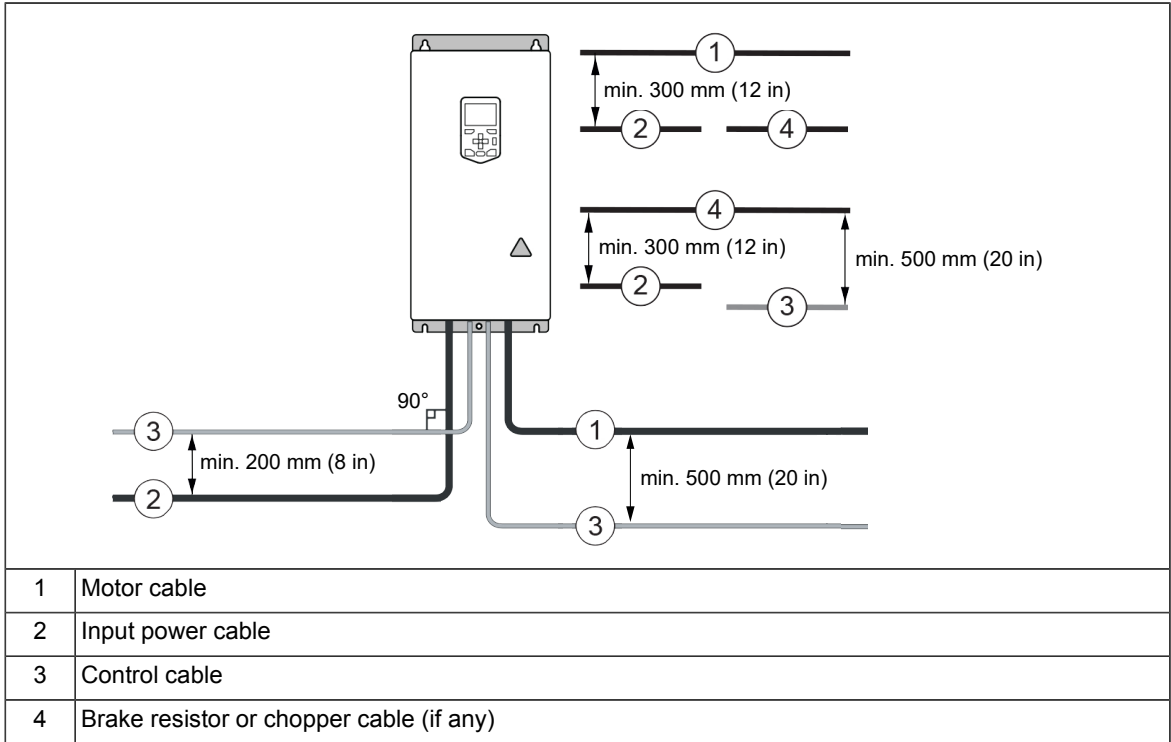

■ General guidelines – North America

Make sure that the installation is in accordance with national and local codes. Obey these general guidelines:

- Use separate conduits for the input power, motor, brake resistor (optional), and control cabling.
- Use separate conduit for each motor cabling.

The following figure illustrates the cable routing guidelines with an example drive.

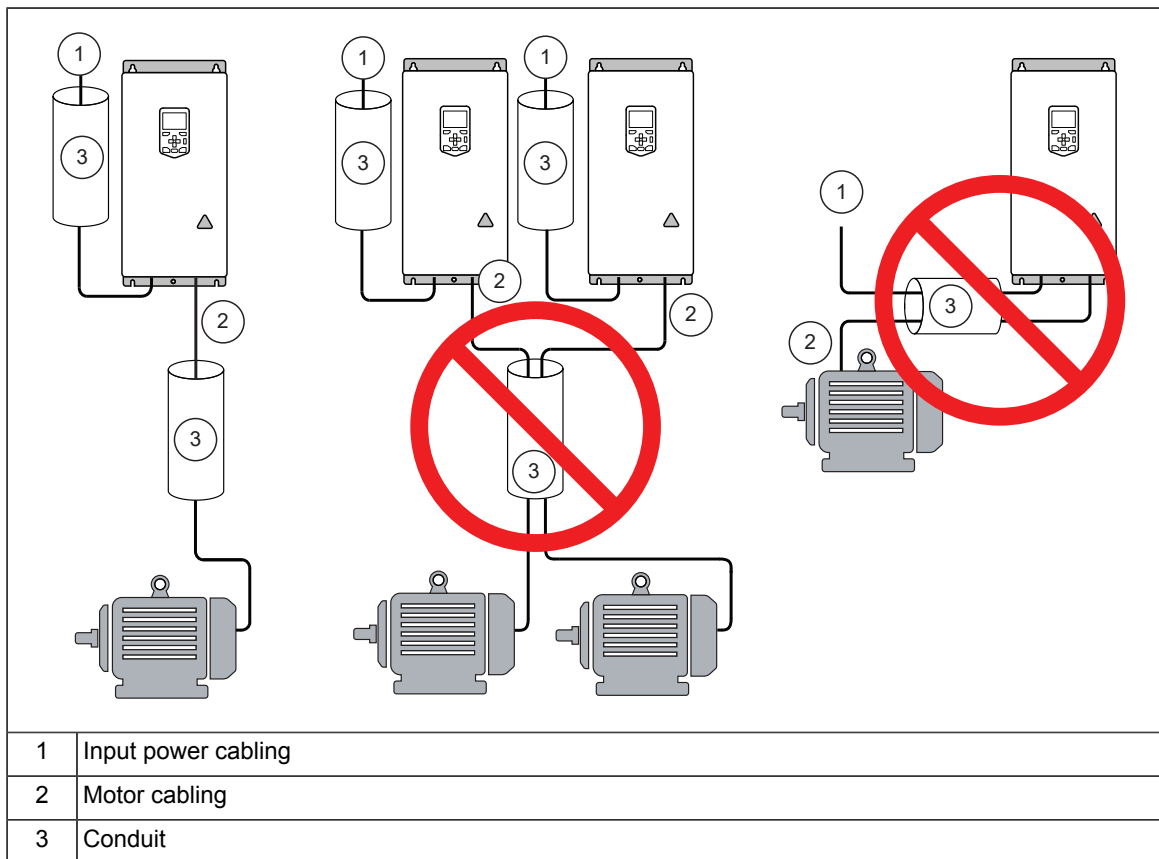

■ **Continuous motor cable shield/conduit or enclosure for equipment on the motor cable**

To minimize the emission level when safety switches, contactors, connection boxes or similar equipment are installed on the motor cable between the drive and the motor:

- Install the equipment in a metal enclosure.
- Use either a symmetrical shielded cable, or install the cabling in a metal conduit.
- Make sure that there is a good and continuous galvanic connection in the shield/conduit between drive and motor.
- Connect the shield/conduit to the protective ground terminal of the drive and the motor.

■ **Separate control cable ducts**

Put 24 V DC and 230 V AC (120 V AC) control cables in separate ducts, unless the 24 V DC cable is insulated for 230 V AC (120 V AC) or insulated with an insulation sleeving for 230 V AC (120 V AC).

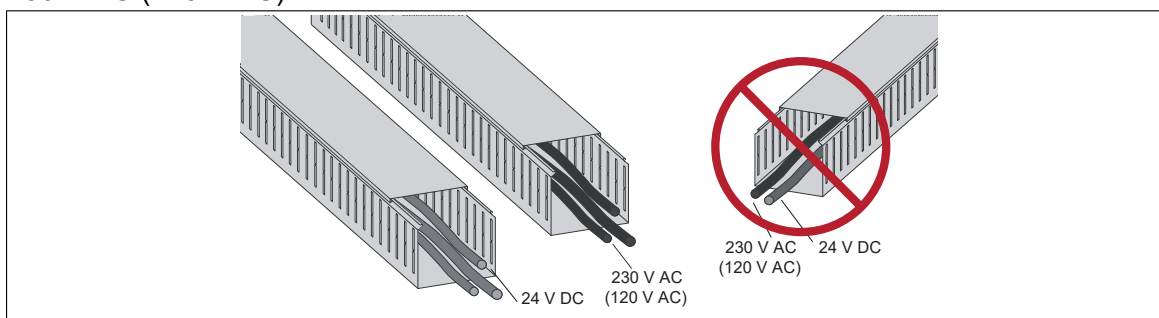

Implementing short-circuit and thermal overload protection

■ Protecting the drive and the input power cable in short-circuits

Protect the drive with fuses and the input cable with fuses or a circuit breaker.

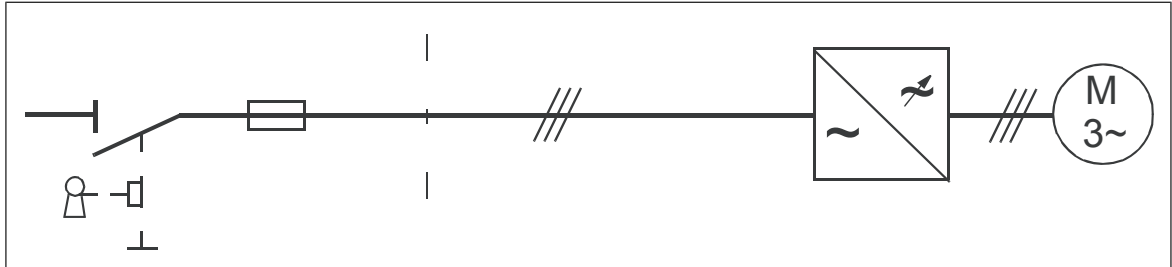

Size the fuses or circuit breakers according to local regulations for the input cable protection. Select the fuses or circuit breakers for the drive according to the instructions given in the technical data. The fuses for the drive protection will restrict drive damage and prevent damage to adjoining equipment in case of a short-circuit inside the drive.

Note: If the fuses or circuit breakers for the drive protection are placed at the distribution board and the input cable is dimensioned according to the nominal input current of the drive given in the technical data, the fuses or circuit breakers protect also the input cable in short-circuit situations, restrict drive damage and prevent damage to adjoining equipment in case of a short-circuit inside the drive. No separate fuses or circuit breakers for the input cable protection are needed.



WARNING!

Due to the inherent operating principle and construction of circuit breakers, independent of the manufacturer, hot ionized gases can escape from the breaker enclosure in case of a short-circuit. To ensure safe use, pay special attention to the installation and placement of the breakers. Obey the manufacturer's instructions.

■ Protecting the motor and motor cable in short-circuits

The drive protects the motor cable and motor in a short-circuit situation when the motor cable is sized according to the nominal current of the drive. No additional protection devices are needed.

■ Protecting the motor cables against thermal overload

The drive protects the motor cables against thermal overload when the cables are sized according to the nominal output current of the drive. No additional thermal protection devices are needed.



WARNING!

If the drive is connected to multiple motors, use a separate circuit breaker or fuses for protecting each motor cable and motor against overload. The overload protection of the drive is tuned for the total motor load. It may not detect an overload in one motor circuit only.

■ Protecting the motor against thermal overload

According to regulations, the motor must be protected against thermal overload and the current must be switched off when overload is detected. The drive includes a motor thermal protection function that protects the motor and switches off the current when necessary.

Depending on a drive parameter value, the function either monitors a calculated temperature value (based on a motor thermal model) or an actual temperature indication given by motor temperature sensors.

The motor thermal protection model supports thermal memory retention and speed sensitivity. The user can tune the thermal model further by feeding in additional motor and load data.

The most common temperature sensor types are thermal switch (for example Klixon), PTC or Pt100.

For more information, see the firmware manual.

■ **Protecting the motor against overload without thermal model or temperature sensors using an external overload device**

Motor overload protection protects the motor against overload without using motor thermal model or temperature sensors.

Motor overload protection is required and specified by multiple standards including the US National Electric Code (NEC) and the common UL/IEC 61800-5-1 standard in conjunction with UL/IEC 60947-4-1. The standards allow for motor overload protection without external temperature sensors.

The protection feature allows the user to specify the class of operation in the same manner as the overload relays are specified in standards UL/IEC 60947-4-1 and NEMA ICS 2.

The motor overload protection supports thermal memory retention and speed sensitivity.

For more information, see the firmware manual.

Protecting the drive against ground faults

The drive is equipped with an internal ground fault protective function to protect the unit against ground faults in the motor and motor cable. This function is not a personnel safety or a fire protection feature. See the firmware manual for more information.

■ **Residual current device compatibility**

The drive is suitable to be used with residual current devices of Type B.

Note: As standard, the drive contains capacitors connected between the main circuit and the frame. These capacitors and long motor cables increase the ground leakage current and may cause nuisance faults in residual current devices.

Connecting drives to a common DC system

See *ACS880-01 drives and ACS880-04 drive modules common DC systems application guide* ([3AJA0000127818](#) [English]).

Implementing the emergency stop function

For safety reasons, install the emergency stop devices at each operator control station and at other operating stations where emergency stop may be needed. Implement the emergency stop according to relevant standards.

Note: You can use the Safe torque off function of the drive to implement the Emergency stop function.

Implementing the Safe torque off function

See *The Safe torque off function (page 257)*.

Implementing the functions provided by the FSO-xx safety functions module

You can order the drive with an FSO-12 or FSO-21 safety functions module (option +Q972 or +Q973) which enables the implementation of functions such as Safe brake control (SBC), Safe stop 1 (SS1), Safe stop emergency (SSE), Safely limited speed (SLS) and Safe maximum speed (SMS).

The settings of the FSO-xx module are at default when delivered from the factory. The wiring of the external safety circuit and configuration of the FSO-xx module are the responsibility of the user.

The FSO-xx module reserves the standard Safe torque off (STO) connection of the drive control unit. STO can still be utilized by other safety circuits through the FSO-xx.

See the appropriate manual for more information.

Name	Code
<i>FSO-12 safety functions module user's manual</i>	3AXD50000015612
<i>FSO-21 safety functions module user's manual</i>	3AXD50000015614

Implementing an ATEX-certified motor thermal protection

With option +Q971, the drive provides ATEX-certified safe motor disconnection without contactor using the drive Safe torque off function. To implement the thermal protection of a motor in explosive atmosphere (Ex motor), you must also:

- use an ATEX-certified Ex motor
- order an ATEX-certified thermistor protection module for the drive (option +L357), or acquire and install an ATEX-compliant protection relay
- do the necessary connections.

For more information, see:

User's manual	Manual code (English)
<i>ATEX-certified Safe disconnection function, Ex II (2) GD for ACS880 drives (+Q971) application guide</i>	3AUJA0000132231
<i>FPTC-02 ATEX-certified thermistor protection module, Ex II (2) GD (option +L537+Q971) for ACS880 drives user's manual</i>	3AXD50000027782

Implementing the Power-loss ride-through function

Implement the power-loss ride-through function as follows:

- Check that the power-loss ride-through function of the drive is enabled with parameter **30.31 Undervoltage control** in the ACS880 primary control program.
- If the installation is equipped with a main contactor, prevent its tripping at the input power break. For example, use a time delay relay (hold) in the contactor control circuit.



WARNING!

Make sure that the flying restart of the motor will not cause any danger. If you are in doubt, do not implement the Power-loss ride-through function.

Using power factor compensation capacitors with the drive

Power factor compensation is not needed with AC drives. However, if a drive is to be connected in a system with compensation capacitors installed, note the following restrictions.



WARNING!

Do not connect power factor compensation capacitors or harmonic filters to the motor cables (between the drive and the motor). They are not meant to be used with AC drives and can cause permanent damage to the drive or themselves.

If there are power factor compensation capacitors in parallel with the input of the drive:

1. Do not connect a high-power capacitor to the power line while the drive is connected. The connection will cause voltage transients that may trip or even damage the drive.
2. If capacitor load is increased/decreased step by step when the AC drive is connected to the power line, make sure that the connection steps are low enough not to cause voltage transients that would trip the drive.
3. Make sure that the power factor compensation unit is suitable for use in systems with AC drives, ie, harmonic generating loads. In such systems, the compensation unit should typically be equipped with a blocking reactor or harmonic filter.

Controlling a contactor between drive and motor

The control of the output contactor depends on how you use the drive, that is, which motor control mode and which motor stop mode you select.

If you have the DTC motor control mode and the motor ramp stop mode selected, use this operation sequence to open the contactor:

1. Give a stop command to the drive.
2. Wait until the drive decelerates the motor to zero speed.
3. Open the contactor.

If you have the DTC motor control mode and the motor coast stop, or scalar control mode selected, open the contactor as follows:

1. Give a stop command to the drive.
2. Open the contactor.



WARNING!

When the DTC motor control mode is in use, never open the output contactor while the drive controls the motor. The DTC motor control operates extremely fast, much faster than it takes for the contactor to open its contacts. When the contactor starts opening while the drive controls the motor, the DTC control will try to maintain the load current by immediately increasing the drive output voltage to the maximum. This will damage, or even burn the contactor completely.

Implementing a bypass connection

If bypassing is required, employ mechanically or electrically interlocked contactors between the motor and the drive and between the motor and the power line. Make sure with interlocking that the contactors cannot be closed simultaneously. The installation must be clearly marked as defined in IEC/EN 61800-5-1, subclause 6.5.3, for example, "THIS MACHINE STARTS AUTOMATICALLY".



WARNING!

Never connect the drive output to the electrical power network. The connection may damage the drive.

■ Example bypass connection

An example bypass connection is shown below.

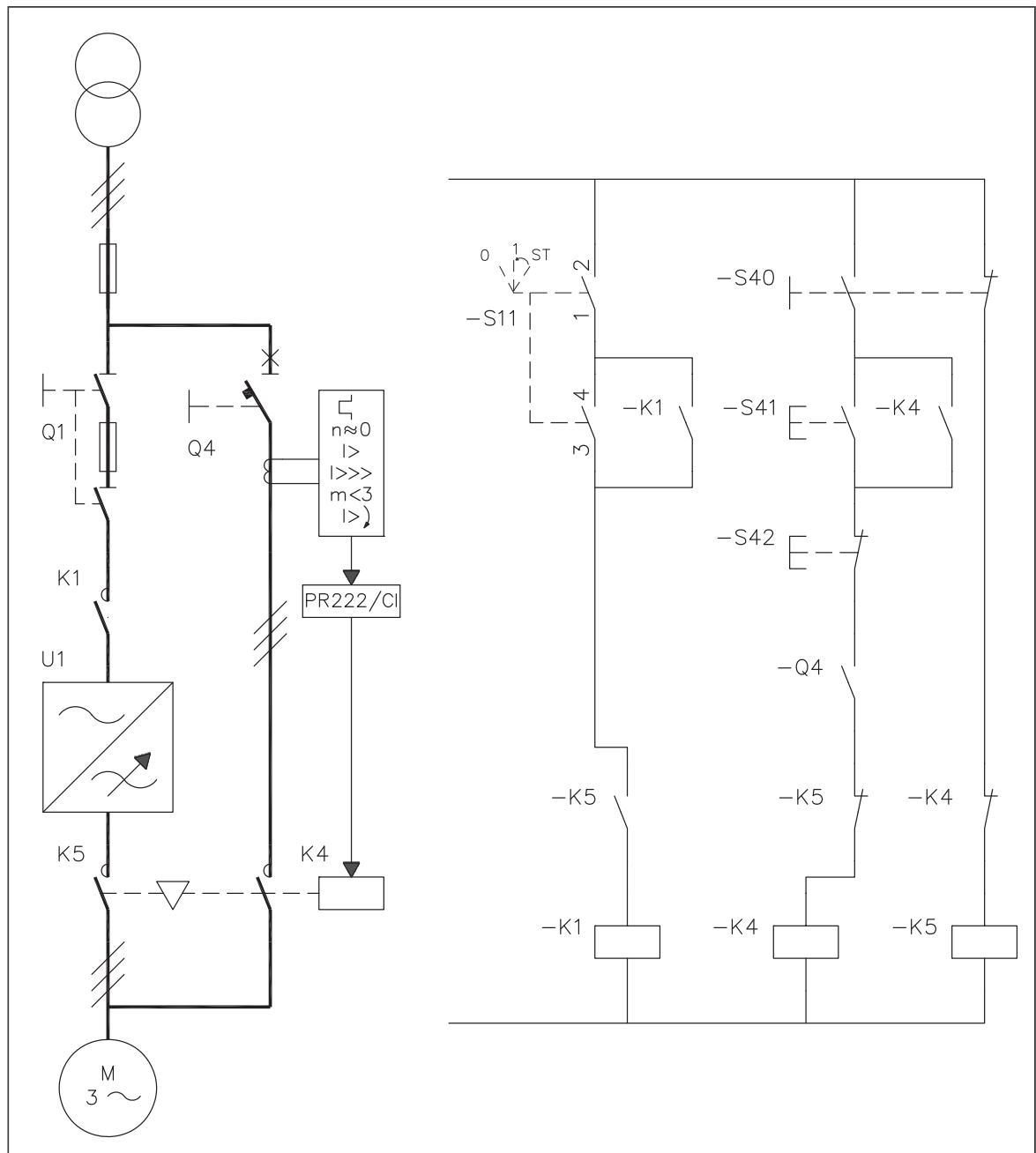

Q1	Drive main switch	S11	Drive main contactor on/off control
Q4	Bypass circuit breaker	S40	Motor power supply selection (drive or direct-on-line)
K1	Drive main contactor	S41	Start when motor is connected direct-on-line
K4	Bypass contactor	S42	Stop when motor is connected direct-on-line
K5	Drive output contactor	-	-

Switching the motor power supply from drive to direct-on-line

1. Stop the drive and the motor with the drive control panel (drive in local control mode) or with the external stop signal (drive in remote control mode).
2. Open the main contactor of the drive with S11.
3. Switch the motor power supply from the drive to direct-on-line with S40.
4. Wait for 10 seconds to allow the motor magnetization to die away.
5. Start the motor with S41.

Switching the motor power supply from direct-on-line to drive

1. Stop the motor with S42.
2. Switch the motor power supply from direct-on-line to the drive with S40.
3. Close the main contactor of the drive with switch S11 (-> turn to position ST for two seconds and leave at position 1).
4. Start the drive and the motor with the drive control panel (drive in local control mode) or with the external start signal (drive in remote control mode).

Protecting the contacts of relay outputs

Inductive loads (relays, contactors, motors) cause voltage transients when switched off.

The relay contacts on the drive control unit are protected with varistors (250 V) against overvoltage peaks. In spite of this, it is highly recommended that inductive loads are equipped with noise attenuating circuits (varistors, RC filters [AC] or diodes [DC]) to minimize the EMC emission at switch-off. If not suppressed, the disturbances may connect capacitively or inductively to other conductors in the control cable and form a risk of malfunction in other parts of the system.

Install the protective component as close to the inductive load as possible. Do not install protective components at the relay outputs.

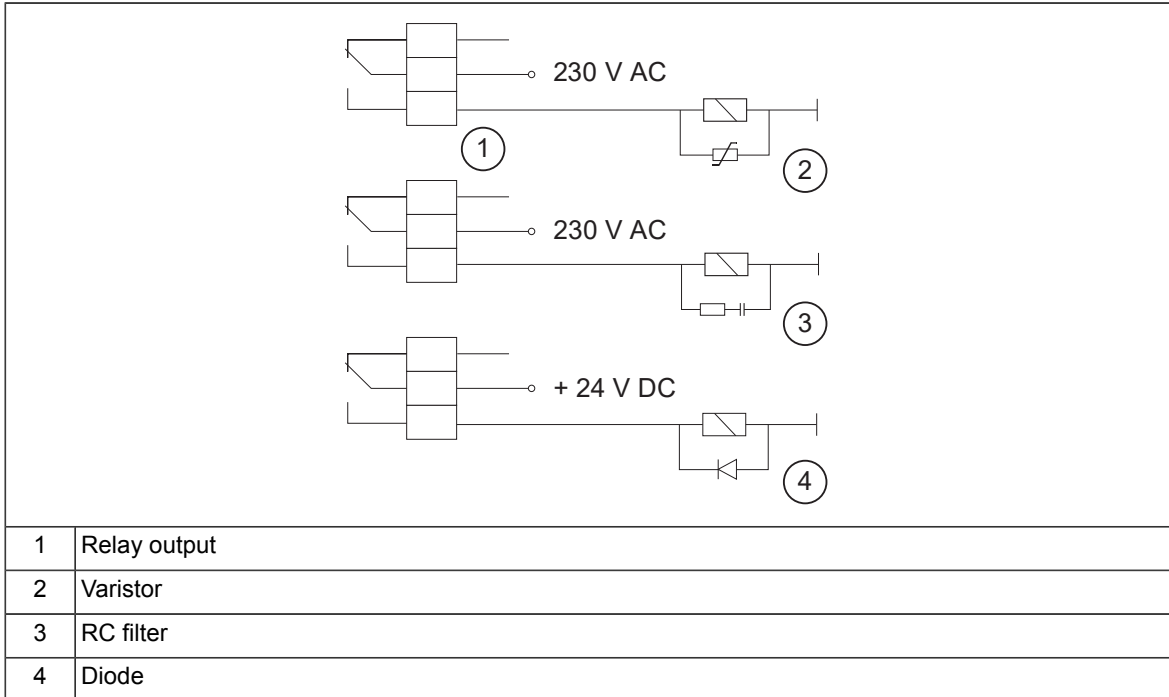

Implementing a motor temperature sensor connection



WARNING!

IEC 60664 and IEC 61800-5-1 require double or reinforced insulation between live parts and accessible parts when:

- the accessible parts are not conductive, or
- the accessible parts are conductive, but not connected to the protective earth.

Obey this requirement when you plan the connection of the motor temperature sensor to the drive.

To connect a motor temperature sensor and other similar components to the drive, you have four alternatives:

1. If there is double or reinforced insulation between the sensor and the live parts of the motor, you can connect the sensor directly to the inputs of the drive.
2. If there is basic insulation between the sensor and the live parts of the motor, you can connect the sensor to the analog/digital inputs of the drive if all circuits connected to the drive's digital and analog inputs (typically extra-low voltage circuits) are protected against contact and insulated with basic insulation from other low-voltage circuits. The insulation must be rated for the same voltage level as the drive main circuit. Note that extra-low voltage circuits (such as 24 V DC) typically do not meet these requirements.
3. You can connect the sensor to the drive via an option module. The sensor and the module must form a double or reinforced insulation between the motor live parts and the drive control unit. See section [Connection of motor temperature sensor to the drive via an option module \(page 100\)](#).
4. You can connect the sensor to a digital input of the drive via a customer's external relay. The sensor and the relay must form a double or reinforced insulation between the motor live parts and the drive control unit. See section [Connection of motor temperature sensor to the drive via a relay \(page 101\)](#).

■ Connecting motor temperature sensor to the drive via an option module

This table shows:

- the option module types that you can use for the motor temperature sensor connection
- the insulation or isolation level that each option module forms between its temperature sensor connector and other connectors
- the temperature sensor types that you can connect to each option module
- the temperature sensor insulation requirement in order to form, together with the insulation of the option module, a reinforced insulation between the motor live parts and the drive control unit.

Option module		Temperature sensor type			Temperature sensor insulation requirement
Type	Insulation/Isolation	PTC	KTY	Pt100, Pt1000	
FIO-11	Galvanic isolation between sensor connector and other connectors (including drive control unit connector)	-	x	x	Reinforced insulation
FEN-xx	Galvanic isolation between sensor connector and other connectors (including drive control unit connector)	x	x	-	Reinforced insulation
FAIO-01	Basic insulation between sensor connector and drive control unit connector. No insulation between sensor connector and other I/O connectors.	x	x	x	Basic insulation. Connectors of option module other than sensor connector must be left unconnected.
FPTC-xx ¹⁾	Reinforced insulation between sensor connector and other connectors (including drive control unit connector).	x	-	-	No special requirement

¹⁾ Suitable for use in safety functions (SIL2 / PL c rated).

■ Connection of motor temperature sensor to the drive via a relay

PTC (IEC 60800-5-1)

Class A. This table shows the insulation requirement for a customer's external relay, and the insulation requirement for the sensor to fulfill decisive voltage class A (double insulation).

PTC relay		Temperature sensor insulation requirement
Type	Insulation	
External relay	Basic insulation 6 kV	Basic insulation

Class B. Decisive voltage class B (basic insulation) is provided with a 6 kV relay. Circuits connected to all motor protection relay inputs and outputs must be protected against direct contact.

Pt100 (IEC 90800-5-1)

Class B. Decisive voltage class B (basic insulation) can be achieved when there is basic insulation between the sensor and live parts of the motor. Circuits connected to all motor protection relay inputs and outputs must be protected against direct contact.

P100 relay		Temperature sensor insulation requirement between sensor and live parts of motor
Type	Insulation	
External relay	Basic insulation 6 kV	Basic insulation

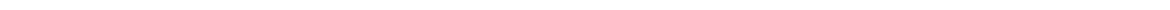

6

Electrical installation – IEC

Contents of this chapter

This chapter gives instructions on wiring the drive.

Safety



WARNING!

If you are not a qualified electrical professional, do not do installation or maintenance work. Obey the safety instructions of the drive. If you ignore them, injury or death, or damage to the equipment can occur.

Required tools

To do the electrical installation, you need the these tools:

- wire stripper
- screwdriver set (Torx, flat and/or Phillips, as appropriate)
- torque wrench.

Grounding the motor cable shield at the motor end

For minimum radio-frequency interference, ground the cable shield 360 degrees at the cable entry of the motor terminal box.

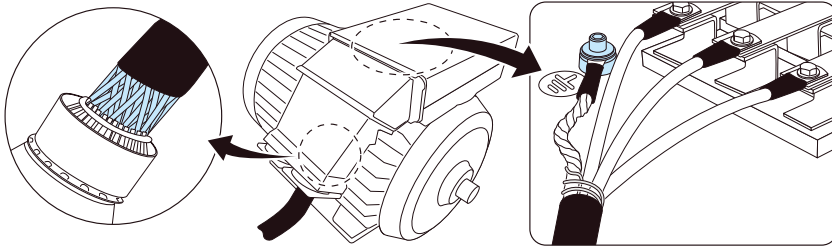

Measuring the insulation

■ Measuring the insulation of the drive



WARNING!

Do not do any voltage withstand or insulation resistance tests on any part of the drive as testing can damage the drive. Every drive has been tested for insulation between the main circuit and the chassis at the factory. Also, there are voltage-limiting circuits inside the drive which cut down the testing voltage automatically.

■ Measuring the insulation of the input power cable

Before you connect the input power cable to the drive, measure its insulation according to local regulations.

■ Measuring the insulation of the motor and motor cable



WARNING!

Obey the safety instructions of the drive. If you ignore them, injury or death, or damage to the equipment can occur.

If you are not a qualified electrical professional, do not do installation or maintenance work.

1. Do the steps in section *Electrical safety precautions (page 15)* before you start the work.
2. Make sure that the motor cable is disconnected from the drive output terminals.
3. Measure the insulation resistance between each phase conductor and the protective earth conductor. Use a measuring voltage of 1000 V DC. The insulation resistance of an ABB motor must be more than 100 Mohm (reference value at 25 °C [77 °F]). For the insulation resistance of other motors, refer to the manufacturer's instructions.

Note: Moisture inside the motor casing reduces the insulation resistance. If you think that there is moisture in the motor, dry the motor and do the measurement again.

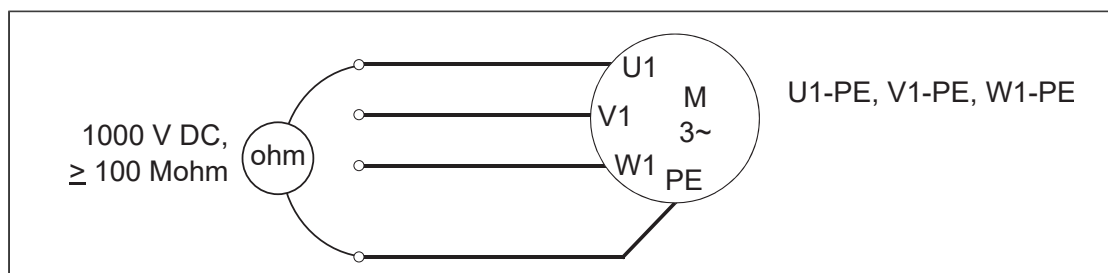

■ Measuring the insulation of the brake resistor circuit



WARNING!

Obey the safety instructions of the drive. If you ignore them, injury or death, or damage to the equipment can occur.

If you are not a qualified electrical professional, do not do installation or maintenance work.

1. Stop the drive and do the steps in section *Electrical safety precautions (page 15)* before you start the work.
2. Make sure that the resistor cable is connected to the resistor and disconnected from the drive output terminals.
3. At the drive end, connect the R+ and R- conductors of the resistor cable together. Measure the insulation resistance between the conductors and the PE conductor with a measuring voltage of 1000 V DC. The insulation resistance must be more than 1 Mohm.

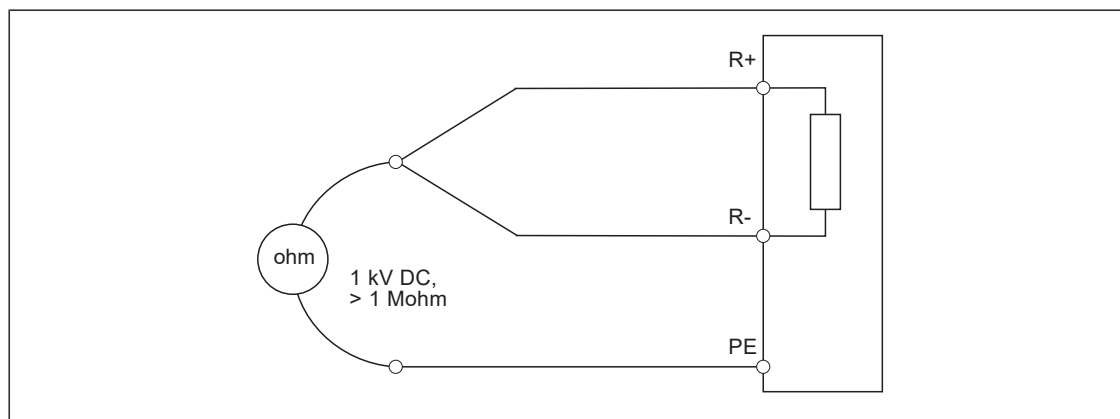

Grounding system compatibility check

The standard drive can be installed to a symmetrically grounded TN-S system. If you install the drive to another system, you may need to disconnect the EMC filter and ground-to-phase varistor. See *ACS880 frames R1 to R11 EMC filter and ground-to-phase varistor disconnecting instructions* ([3AUA0000125152](#) [English]).



WARNING! Do not install the drive with EMC filter options +E200 or +E202 connected to a system that the filter is not suitable for. This can cause danger, or damage the drive.



WARNING! Do not install the drive with the ground-to-phase varistor connected to a system that the varistor is not suitable for. If you do, the varistor circuit can be damaged.

■ Corner-grounded and midpoint-grounded 525...690 V delta systems



WARNING!

Do not install the drive on a 525...690 V corner-grounded or midpoint-grounded delta system. Disconnecting the EMC filter and ground-to-phase varistor does not prevent damage to the drive.

Connecting the power cables

■ Connection diagram

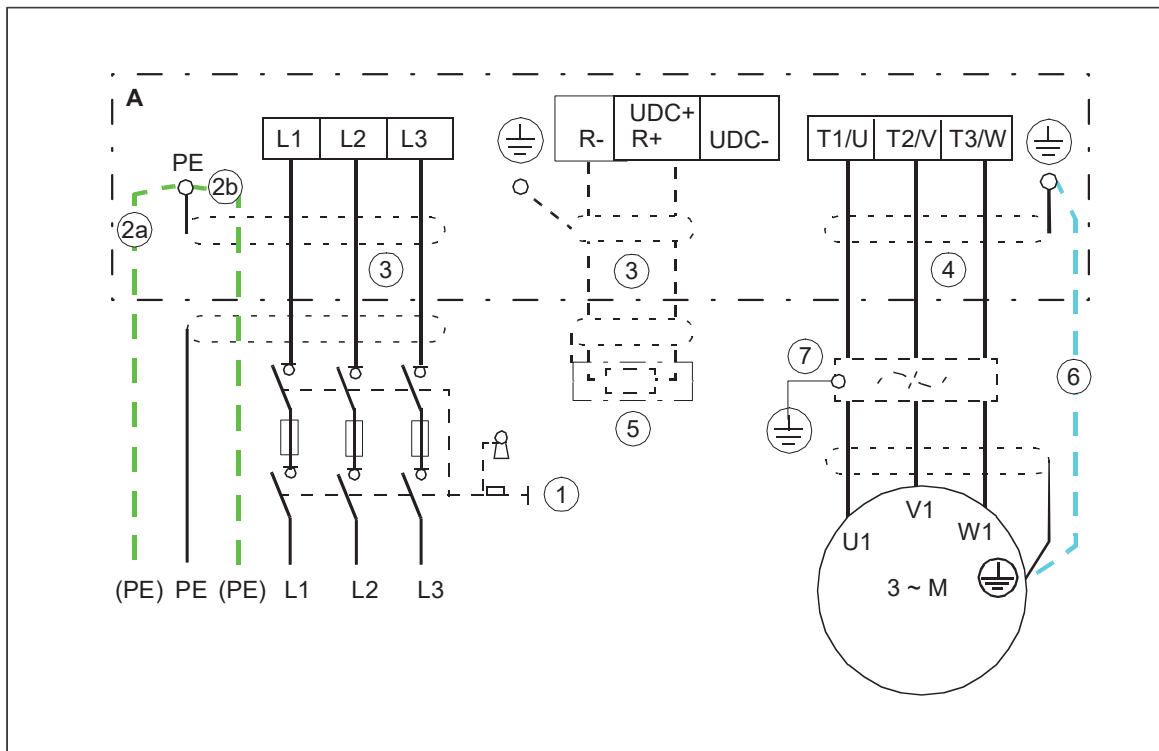

A	Drive
1	For alternatives, see section Selecting the main supply disconnecting device (page 59) .
2	Use a separate grounding PE cable (2a) or a cable with a separate PE conductor (2b) if the conductivity of the shield does not meet the requirements for the PE conductor. See section Selecting the power cables (page 65) .
3	360-degree grounding is recommended if shielded cable is used. Ground the other end of the input cable shield or PE conductor at the distribution board.
4	360-degree grounding is required.
5	External brake resistor
6	Use a separate grounding cable if the shield does not meet the requirements of IEC 61800-5-1 and there is no symmetrically constructed grounding conductor in the cable. See section Selecting the power cables (page 65) .
7	du/dt filter or sine filter (optional, see Filters (page 273)).

Note: If there is a symmetrically constructed grounding conductor on the motor cable in addition to the conductive shield, connect the grounding conductor to the grounding terminal at the drive and motor ends. Do not use an asymmetrically constructed motor cable for motors above 30 kW. Connecting its fourth conductor at the motor end increases bearing currents and causes extra wear.

■ Connection procedure for frames R1 to R3

1. Undo the mounting screws at the sides of the front cover.
2. Remove the cover by sliding it forward.
3. Attach the residual voltage warning sticker in the local language to the control panel mounting platform.
4. Remove the rubber grommets from the entry plate for the cables to be connected.
5. IP21 drives: Attach the cable connectors (included in the delivery in a plastic bag) to the cable entry plate holes.
6. Prepare the input power and motor cable ends as illustrated in the figure.
Note: Bare shield will be grounded 360 degrees.
7. IP21 drives: Ground the shields 360 degrees in the connectors by tightening the connector onto the stripped part of the cable. IP55 drives: Tighten the clamps onto the stripped part of the cables. Mind the sharp edges.
8. Connect the twisted shields of the power cables to the grounding terminals.
9. Connect the additional PE conductor (if used, see page 19) of the input cable to the grounding terminal.
10. Connect the phase conductors of the input cable to the L1, L2 and L3 terminals and the phase conductors of the motor cable to the T1/U, T2/V and T3/W terminals. Connect the brake resistor conductors (if present) to the R+ and R- terminals. Tighten the screws to the torque given in the figure below.
11. Install the control cable grounding shelf in the cable entry box.
12. Attach the cables outside the drive mechanically.



R1...R3

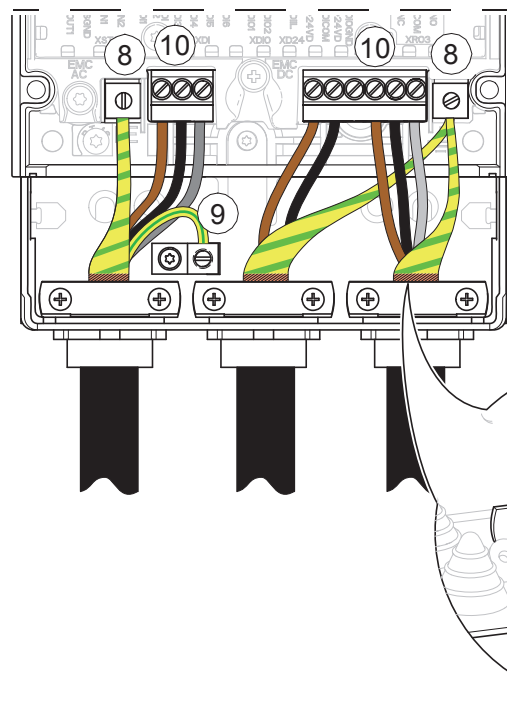
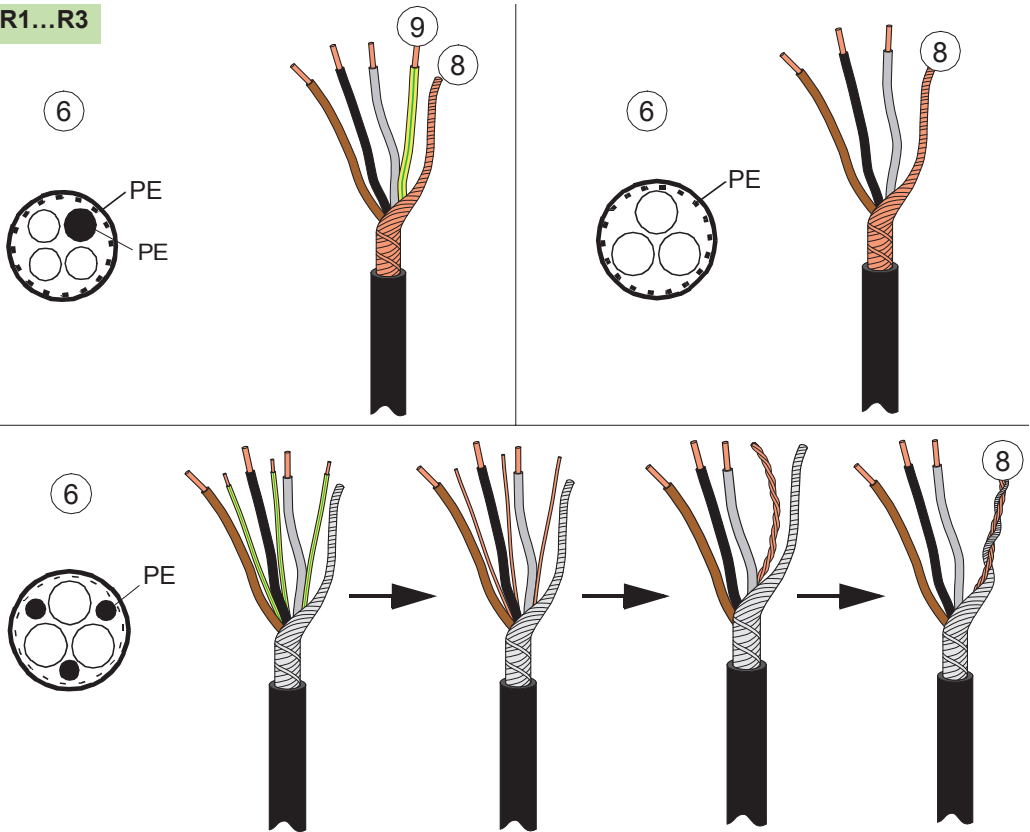

	L1, L2, L3, T1/U, T2/V, T3/W, R-, R+/UDC+, UDC (N·m)	 (N·m)
R1	0.6	1.8
R2	0.6	1.8
R3	1.7	1.8



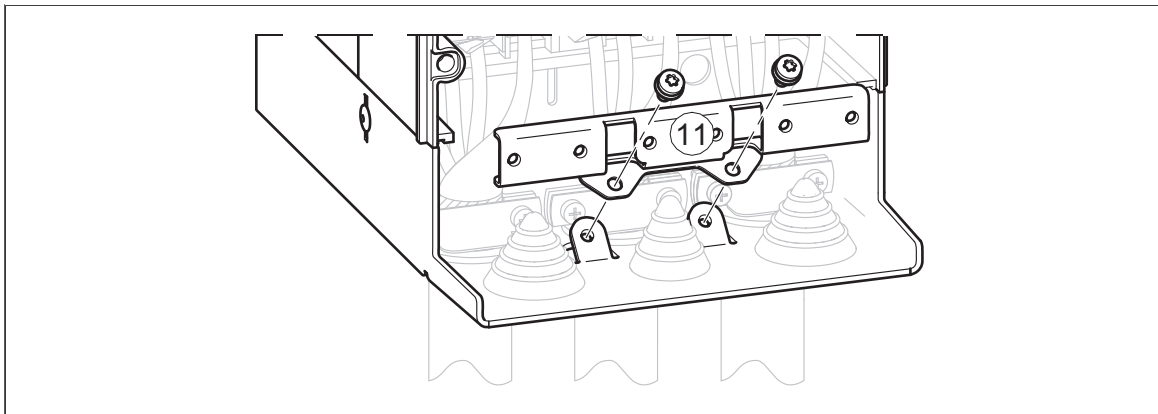

■ Connection procedure for frames R4 and R5

1. Remove the front cover. IP21 drives: Release the retaining clip with a screwdriver (a) and lift the cover from the bottom outwards (b).
2. For IP21 drives: Remove the cable entry box cover by undoing the mounting screw.
3. For frame R4: Remove the EMC shroud that separates the input and output cabling if needed for easier installation.
4. Remove the shroud on the power cable terminals by releasing the clips and lifting the shroud up from the sides with a screwdriver (a). Knock out holes in the shroud for the cables to be installed (b).
5. Attach the residual voltage warning sticker in the local language next to the control unit top.
6. Cut adequate holes into the rubber grommets. Slide the grommets onto the cables. Slide the cables through the holes of the bottom plate and attach the grommets to the holes.
7. Prepare the ends of the input power and motor cables as illustrated in the figure. Bare shield will be grounded 360 degrees under the grounding clamp.
8. Ground the cable shields 360 degrees under the grounding clamps. Mind the sharp edges.
9. Connect the twisted cable shields to the grounding terminals.

10. Connect the phase conductors of the input cable to the L1, L2 and L3 terminals and the phase conductors of the motor cable to the T1/U, T2/V and T3/W terminals. Tighten the screws to the torque given in the figure below.

Note: For cable lug installation (frame R5): Detach the connector and install a cable lug to the terminal post as follows:

- Remove the combi screw that attaches the connector to its terminal post and pull the connector off.
- Attach the cable lug to the conductor.
- Put the cable lug onto the terminal post. Start the nut, and turn it at least two rotations by hand.



WARNING!

Before you use tools, make sure that the nut/screw is not cross-threading. Cross-threading will damage the drive and cause danger.

-
- Undo the nut that attaches the connector to its terminal post and pull the connector off.
 - Attach the cable lug to the conductor.
 - Put the cable lug onto the terminal post. Start the nut, and turn it at least two rotations by hand.



WARNING! Before you use tools, make sure that the nut/screw is not cross-threading. Cross-threading will damage the drive and cause danger.

-
- Tighten the nut to a torque of 5 N·m.
11. Install the EMC shroud separating the input and output cabling if not installed yet.
 12. Drives with option +D150: Slide the brake resistor cable through the brake resistor and control cable clamp assembly. Connect the conductors to the R+ and R- terminals and tighten to the torque given in the figure.
 13. Reinstall the shroud on the power terminals.
 14. Attach the cables outside the unit mechanically. Install the rubber grommets to the unused entry plate holes.



R4, R5

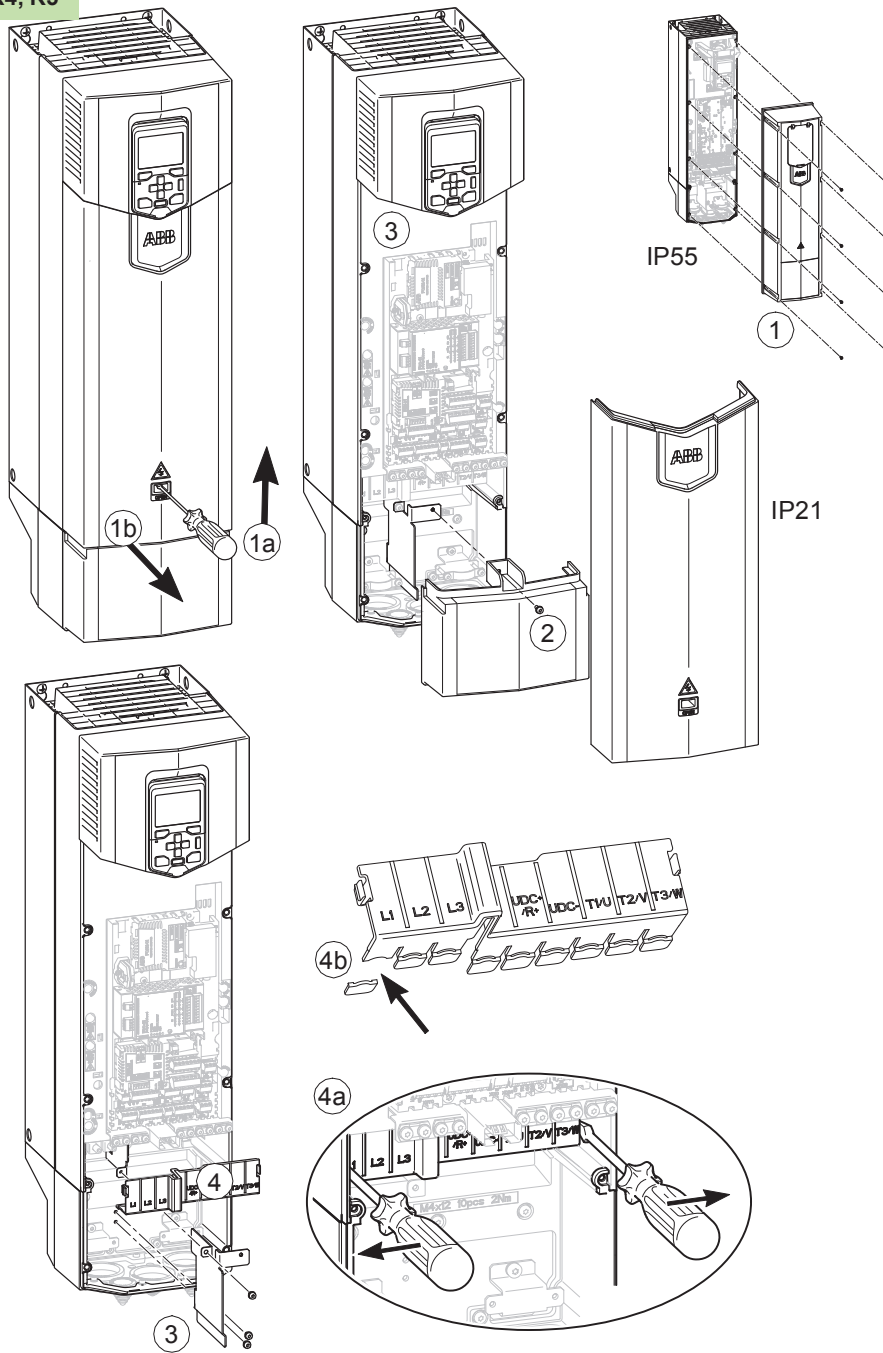

R4, R5

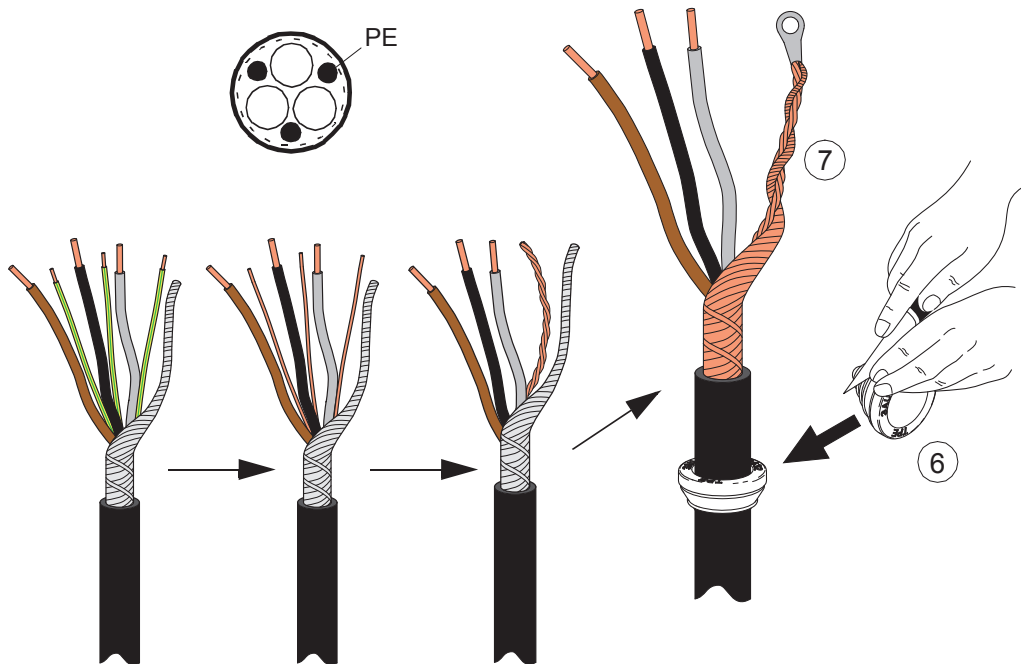
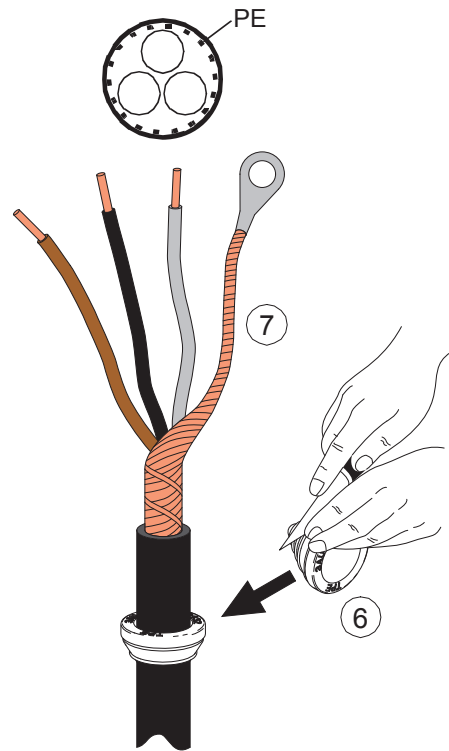
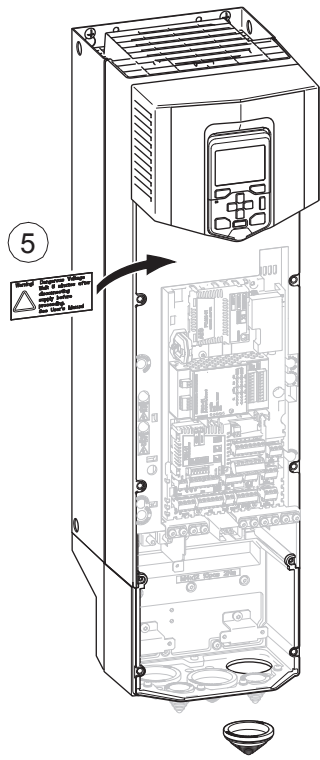

R4, R5

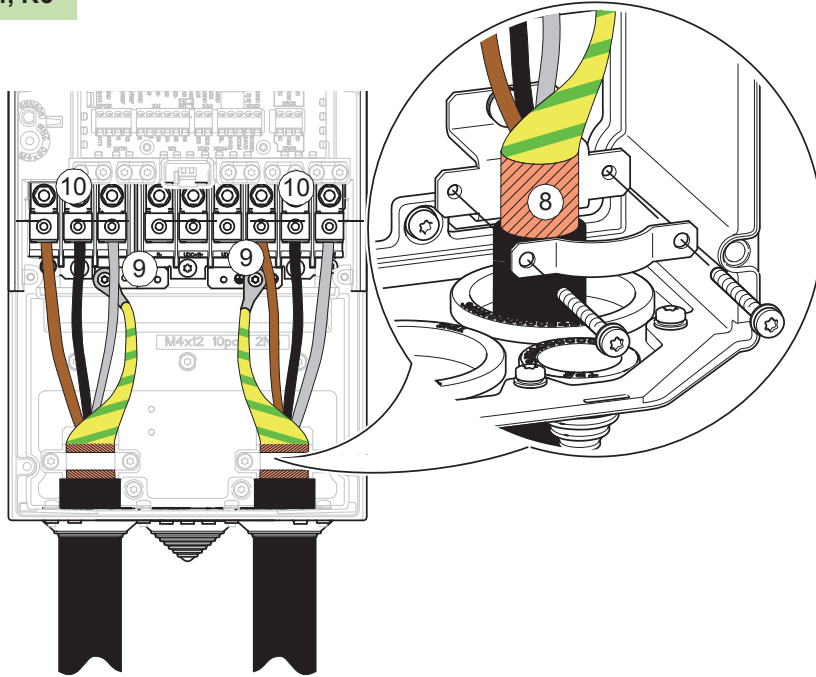

	L1, L2, L3, T1/U, T2/V, T3/W (N·m)	R-, R+/UDC+, UDC- (N·m)	 (N·m)
R4	3.3	3.3	2.9
R5	5.6	5.6	2.9

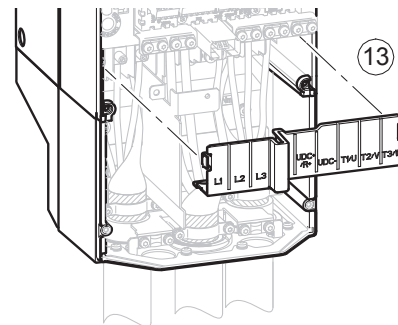
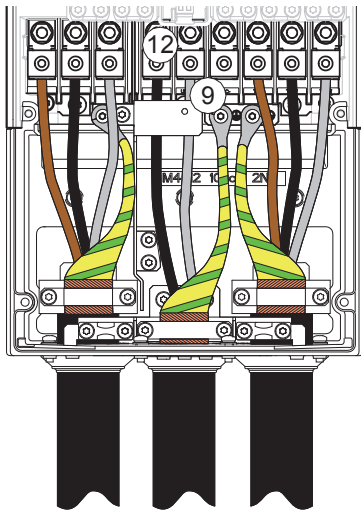
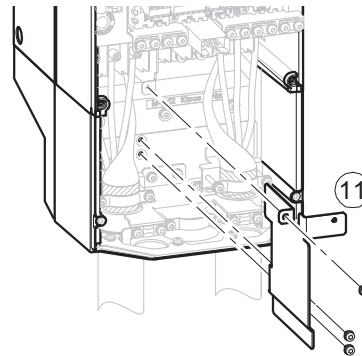

■ Connection procedure for frames R6 to R9

Note: For frames R6 to R9 with option +H358, see also ACS880-01, ACS580-01, ACH580-01, ACQ580-01 UK gland plate (+H358) installation guide ([3AXD50000034735](#) [English]).

1. Remove the front cover: For IP21 drives: Release the retaining clip with a screwdriver (a) and pull the cover by the bottom outwards (b).
2. For IP21 drives: Remove the cable entry box cover by undoing the mounting screws.
3. Attach the residual voltage warning sticker in the local language next to the control unit.
4. Remove the side plates of the cable entry box by undoing the mounting screws.
5. Remove the shroud on the power cable terminals by releasing the clips on the sides with a screwdriver and lifting (a). Knock out holes for the cables to be installed (b).
6. If parallel cables are installed (frames R8 and R9): Knock out the shrouds on the power cable terminals for the cables to be installed.
7. Prepare the ends of the input power and motor cables as illustrated in the figure. The bare shield will be grounded 360 degrees under the clamp.
8. Cut adequate holes into the rubber grommets (a). Slide the grommets onto the cables. Slide the cables through the holes of the bottom plate and attach the grommets to the holes (b).
9. Tighten the clamp onto the stripped part of the cable. Mind the sharp edges.
10. Attach the twisted shields of the cables under the grounding clamps.



11. Connect the phase conductors of the input cable to the L1, L2 and L3 terminals and the phase conductors of the motor cable to the T1/U, T2/V and T3/W terminals. Tighten the screws to the torque given in the figure.

Note: For frames R8 and R9:

- If you put only one conductor to the connector, ABB recommends that you put it under the upper pressure plate.
- ABB does not recommend that you detach the connectors. If you do, detach and reinstall the connector as follows.

L1, L2 and L3 connectors

- a. Remove the combi screw that attaches the connector to its terminal post, and pull the connector off.
- b. Put the conductor under the connector pressure plate and pretighten the conductor.
- c. Put the connector back onto the terminal post. Start the combi screw, and turn it at least two rotations by hand.



WARNING! Before you use tools, make sure that the nut/screw is not cross-threading. Cross-threading will damage the drive and cause danger.

- d. Tighten the combi screw to a torque of 30 N·m.
- e. Tighten the conductor(s) to 40 N·m for frame R8 or to 70 N·m for frame R9.

T1/U, T2/V and T3/W connectors

- a. Remove the nut that attaches the connector to its busbar.
- b. Put the conductor under the connector pressure plate and pretighten the conductor.
- c. Put the connector back to its busbar. Start the nut, and turn it at least two rotations by hand.



WARNING! Before you use tools, make sure that the nut/screw is not cross-threading. Cross-threading will damage the drive and cause danger.

- d. Tighten the nut to a torque of 30 N·m.
- e. Tighten the conductor(s) to 40 N·m for frame R8 or to 70 N·m for frame R9.

Note: Cable lug installation (frames R6 to R9): Detach the connector and install a cable lug to the terminal post / busbar as follows:

- L1, L2, L3: Undo the nut that attaches the connector to the terminal post, and pull the connector off.
- R-, R+, U/T1, V/T2, W/T3: Remove the combi screw that attaches the connector to its terminal post / busbar, and pull the connector off.
- Attach the cable lug to the conductor.
- L1, L2, L3: Put the cable lug onto the terminal post / busbar. Start the nut, and turn it at least two rotations by hand.



WARNING! Before you use tools, make sure that the nut/screw is not cross-threading. Cross-threading will damage the drive and cause danger.

- Tighten the nut to a torque of 16 N·m (frames R6 and R7) and to a torque of 30 N·m (frames R8 and R9).

12. Drives with option +D150: Connect the brake resistor cable conductors to the R+ and R- terminals.
13. If parallel cables are installed (frames R8 and R9), install the grounding shelves for them. Repeat steps 8 to 12.
14. Reinstall the shroud on the power terminals.
15. Reinstall the side plates of the cable entry box.
16. Install the control cable grounding shelf in the cable entry box.
17. Attach the cables outside the drive mechanically. Install the rubber grommets to the unused entry plate holes.



R6 ... R9

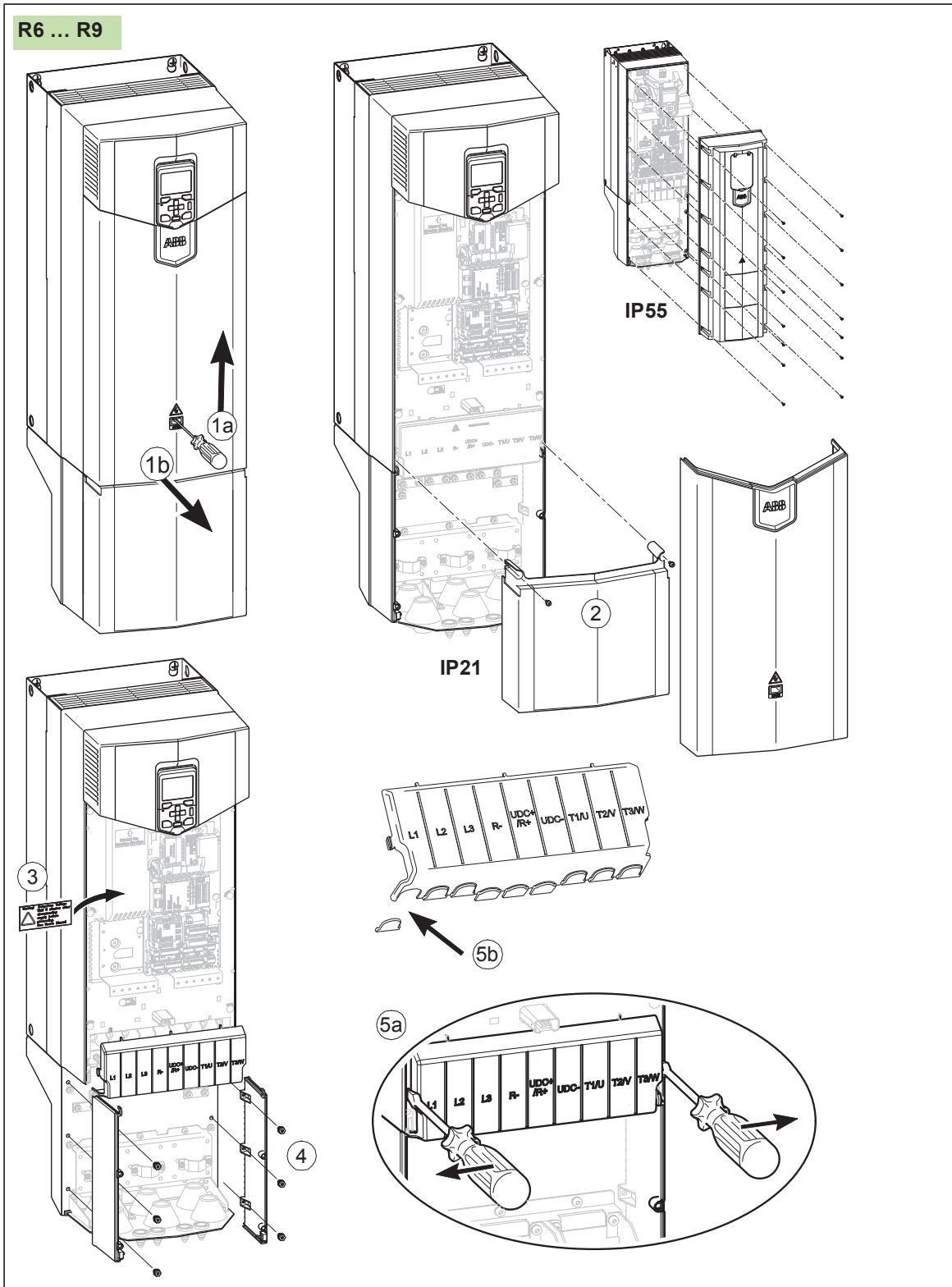

R6 ... R9

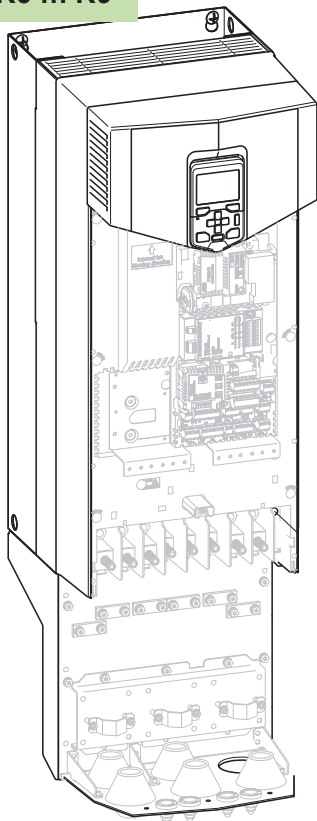

R8, R9

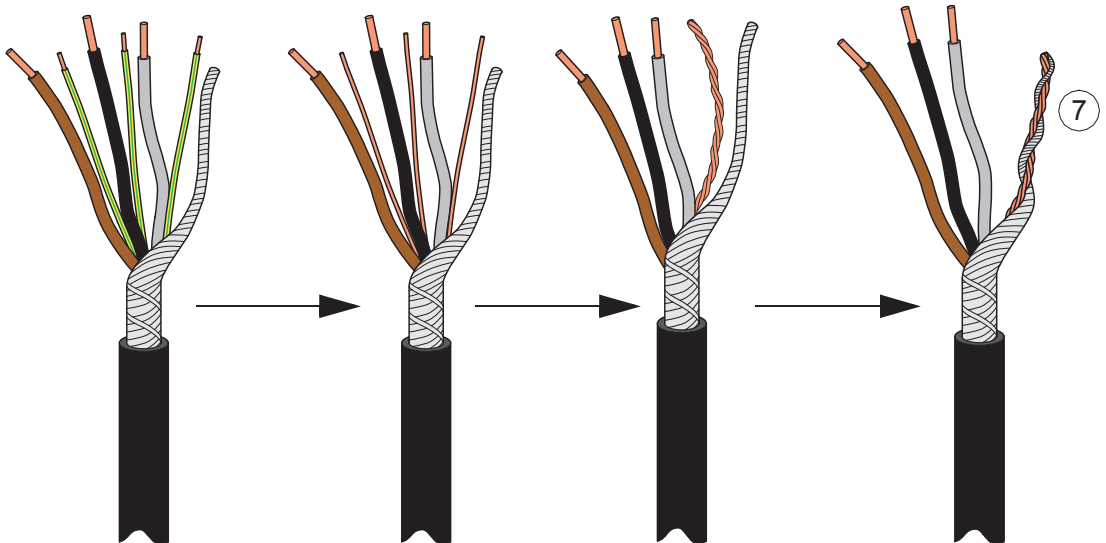
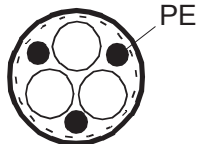
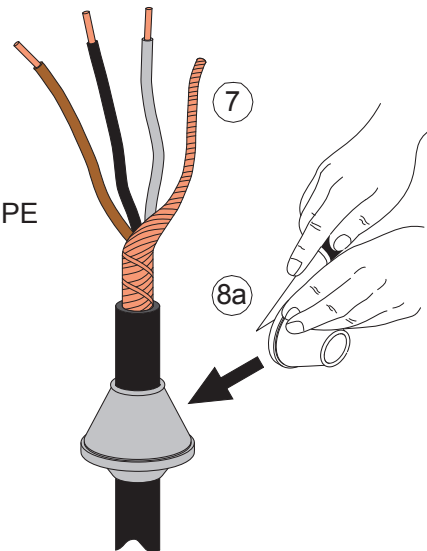
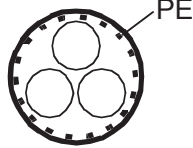
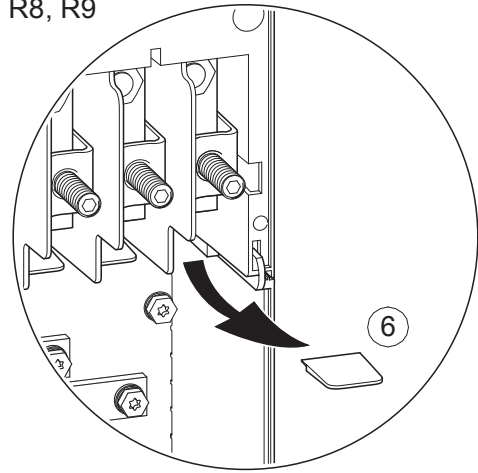

R6 ... R9

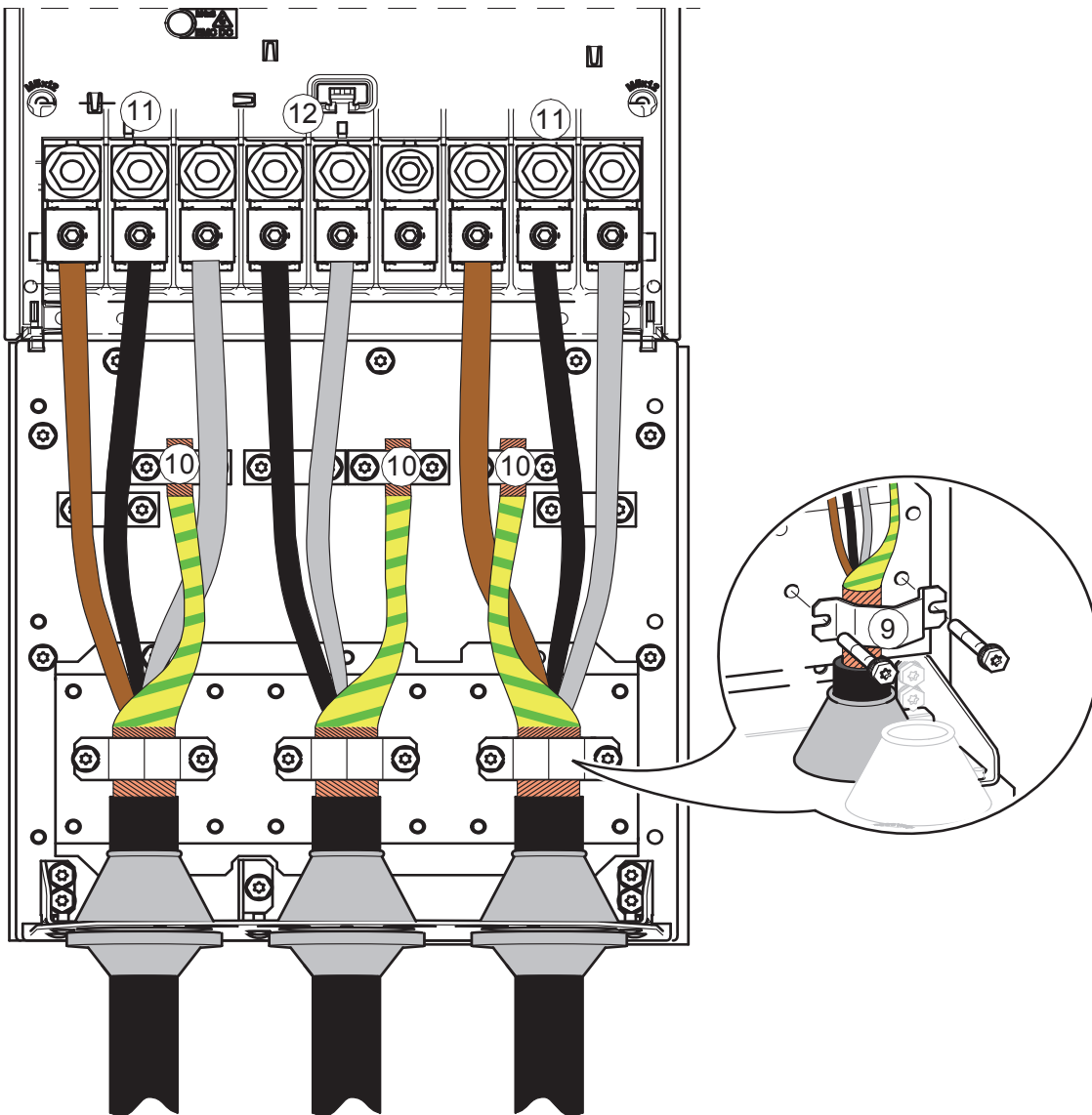

Frame	L1, L2, L3, T1/U, T2/V, T3/W		R-, R+/UDC+, UDC-		
	T (Wire screw)		T (Wire screw)		T
	M...	N·m	M...	N·m	N·m
R6	M10	30	M8	20	9.8
R7	M10	40 (30*)	M10	30	9.8
R8	M10	40	M10	40	9.8
R9	M12	70	M12	70	9.8

* for 525...690 V drives

R6 ... R9

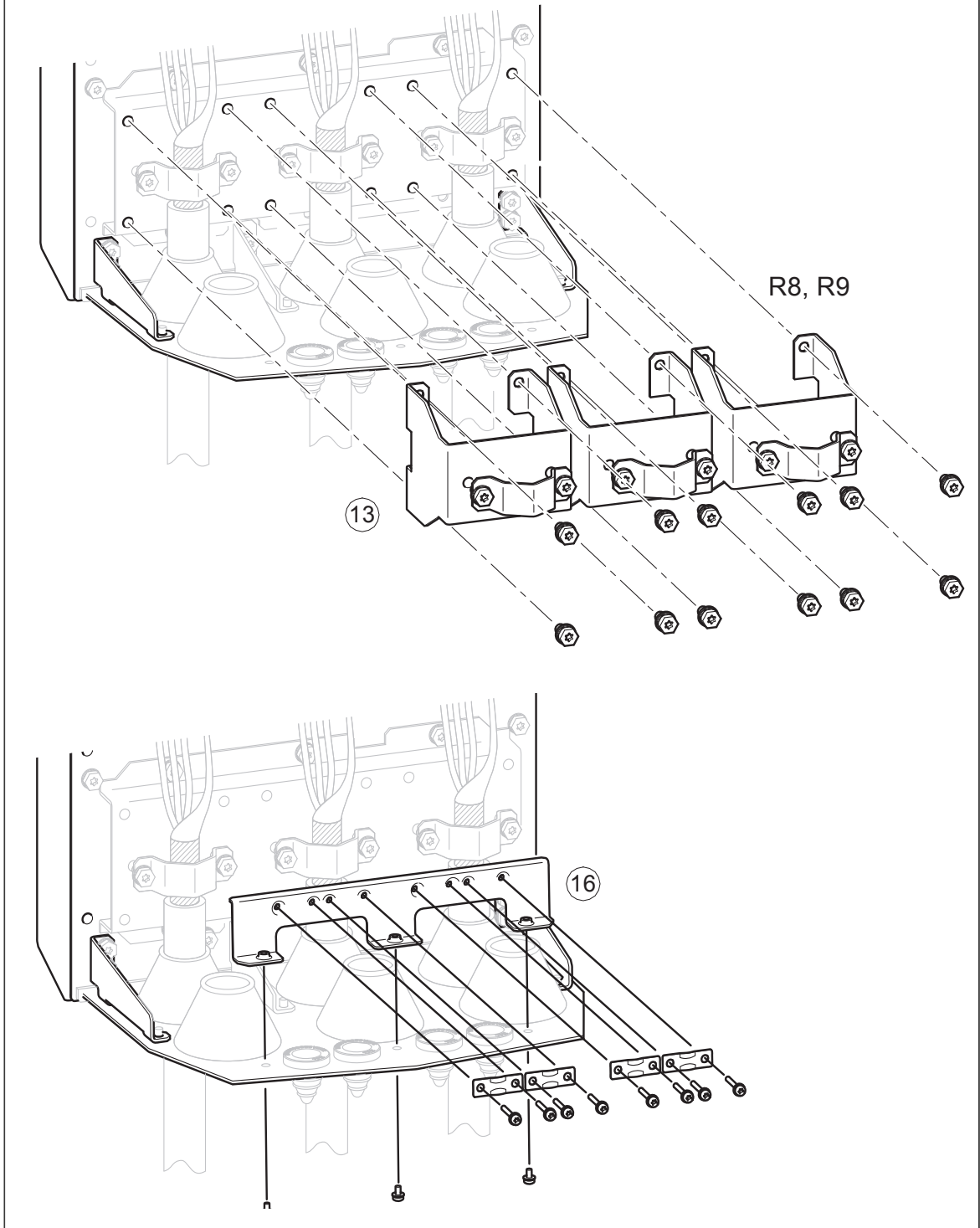

Connecting the control cables

See section [Control units of the drive \(page 135\)](#) for the default I/O connections of the Factory macro of ACS880 primary control program. For other macros and control programs, see the firmware manual.

■ Connection process

This drawing shows an example connection of control cables.

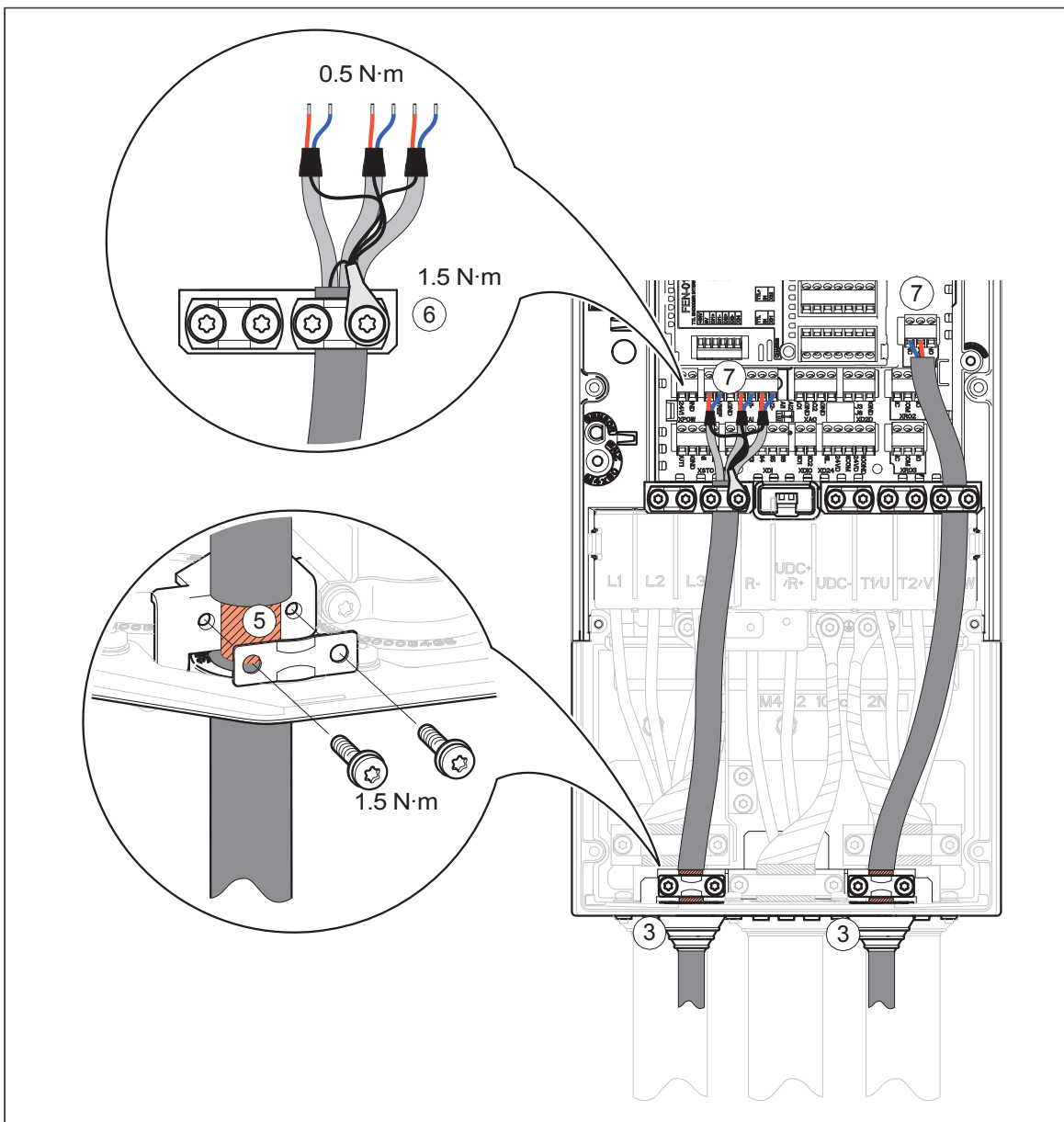

WARNING!

Obey the safety instructions of the drive. If you ignore them, injury or death, or damage to the equipment can occur.

1. Repeat the steps described in *Electrical safety precautions (page 15)*.
2. Remove the front cover(s). See section *Connecting the power cables (page 86)*.
3. Cut adequate holes into the rubber grommets and slide the grommets onto the cables. Slide the cables through the holes of the bottom plate and attach the grommets to the holes.
4. Route the cables as shown below.

5. Ground the outer shields of all control cables 360 degrees at a grounding clamp in the cable entry box. Tighten the clamp to 1.5 N·m (13 lbf·in). Keep the shields continuous as close to the terminals of the control unit as possible. Secure the cables mechanically at the clamps below the control unit. Frames R1 to R3: Ground also the pair-cable shields and grounding wires at the cable entry box grounding clamp.
6. Frames R4 to R9: Ground the pair-cable shields and all grounding wires to the clamp below the control unit.
7. Connect the conductors to the appropriate terminals of the control unit and tighten to 0.5 N·m (5 lbf·in).
8. For connecting the fieldbus cables, see appropriate quick installation guide:

Name	Code (Multilingual)
<i>ACS880-01 quick installation guide for frames R1 to R3</i>	3AJA0000085966
<i>ACS880-01 quick installation guide for frames R4 and R5</i>	3AJA0000099663
<i>ACS880-01 quick installation guide for frames R6 to R9</i>	3AJA0000099689

9. **Note:**
 - Leave the other ends of the control cable shields unconnected or ground them indirectly via a high-frequency capacitor with a few nanofarads, eg, 3.3 nF / 630 V. The shield can also be grounded directly at both ends if they are in the same ground line with no significant voltage drop between the end points.
 - Keep any signal wire pairs twisted as close to the terminals as possible. Twisting the wire with its return wire reduces disturbances caused by inductive coupling.



Connecting a PC



WARNING!

Do not connect the PC directly to the control panel connector of the control unit as this can cause damage.

A PC (with eg, the Drive composer PC tool) can be connected as follows:

1. Connect an ACx-AP-x control panel to the unit either
 - by inserting the control panel into the panel holder or platform, or
 - by using an Ethernet (eg, Cat 5e) networking cable.
2. Remove the USB connector cover on the front of the control panel.
3. Connect an USB cable (Type A to Type Mini-B) between the USB connector on the control panel (3a) and a free USB port on the PC (3b).
4. The panel will display an indication whenever the connection is active.
5. See the documentation of the PC tool for setup instructions.

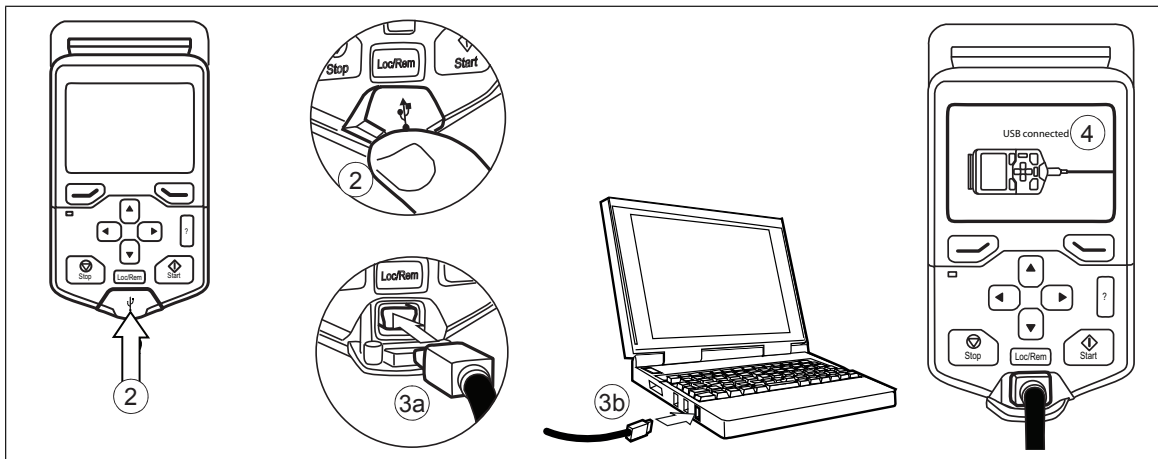

Panel bus (control of several units from one control panel)

One control panel (or PC) can be used to control several drives (or inverter units, supply units etc.) by constructing a panel bus. This is done by daisy-chaining the panel connections of the drives. Some drives have the necessary (twin) panel connectors in the control panel holder; those that do not require the installation of an FDPI-02 module (available separately). For further information, see the hardware description and *FDPI-02 diagnostics and panel interface user's manual* (3AUA0000113618 [English]).

The maximum allowed length of the cable chain is 100 m (328 ft).

1. Connect the panel to one drive using an Ethernet (for example Cat 5e) cable.
 - Use Menu - Settings - Edit texts - Drive to give a descriptive name to the drive
 - Use parameter 49.01* to assign the drive with a unique node ID number
 - Set other parameters in group 49* if necessary
 - Use parameter 49.06* to validate any changes.

*The parameter group is 149 with supply (line-side), brake or DC/DC converter units. Repeat the above for each drive.

2. With the panel connected to one unit, link the units using Ethernet cables.

3. Switch on the bus termination on the drive that is farthest from the control panel in the chain.
 - With drives that have the panel mounted on the front cover, move the terminating switch into the outer position.
 - With an FDPI-02 module, move termination switch S2 into the TERMINATED position.

Make sure that bus termination is off on all other drives.

4. On the control panel, switch on the panel bus functionality (Options - Select drive - Panel bus). The drive to be controlled can now be selected from the list under Options - Select drive.

If a PC is connected to the control panel, the drives on the panel bus are automatically displayed in the Drive composer tool.

With twin connectors in the control panel holder:

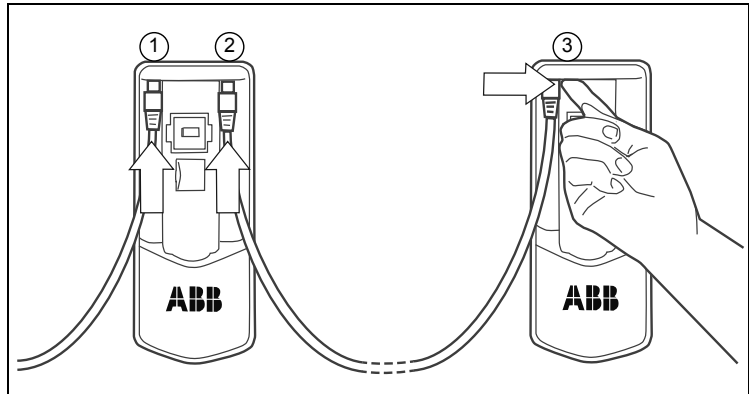
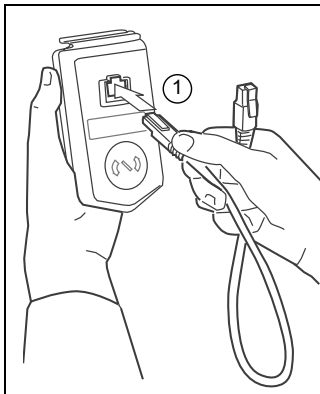

With FDPI-02 modules:

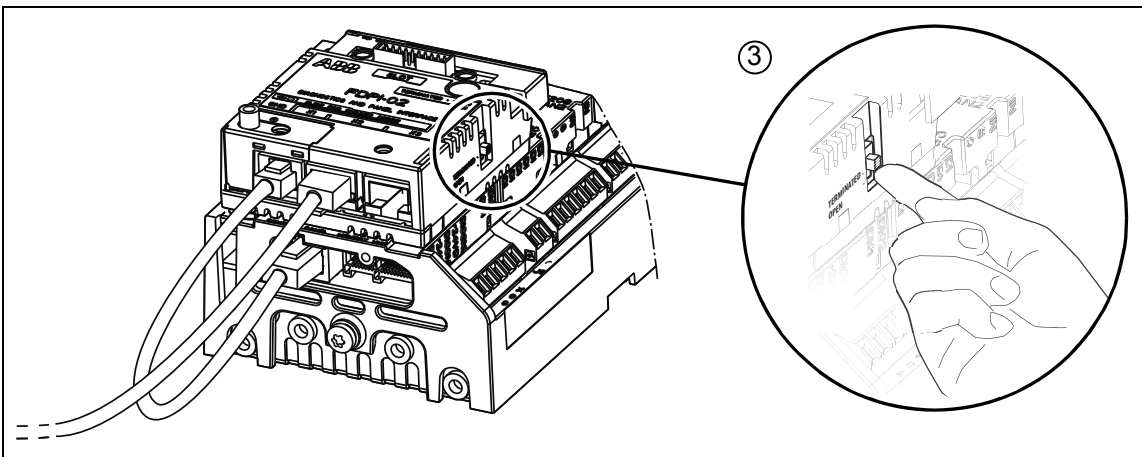
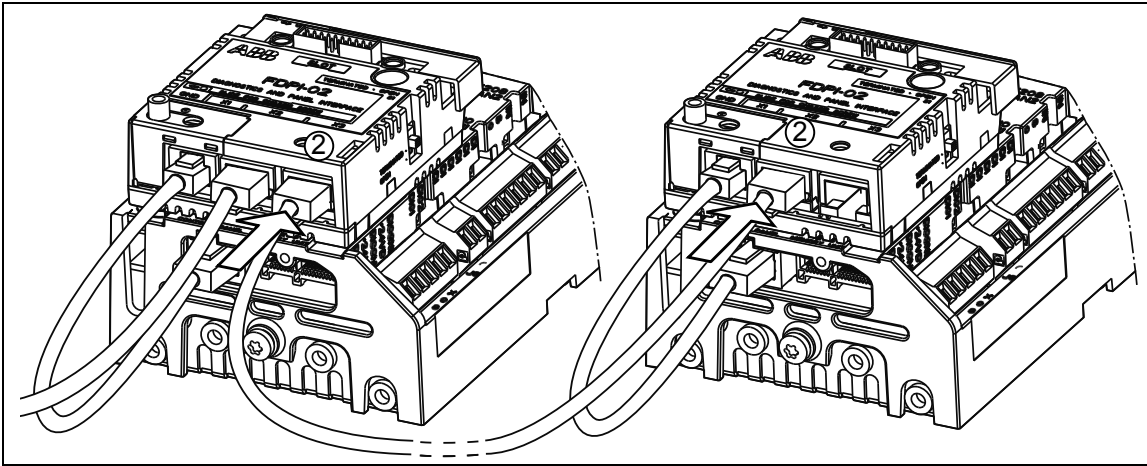
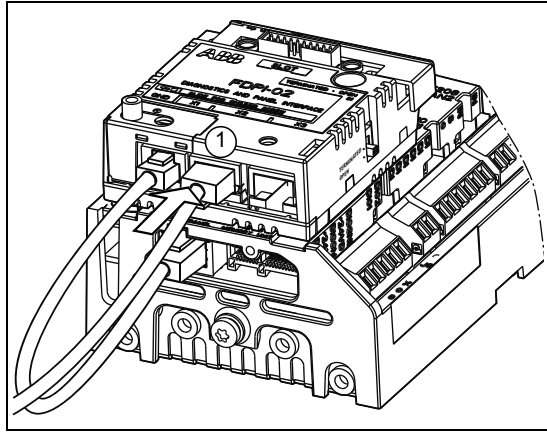
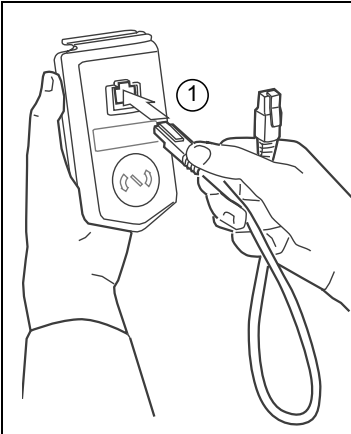

ACS880-01 IP55 (UL Type 12):

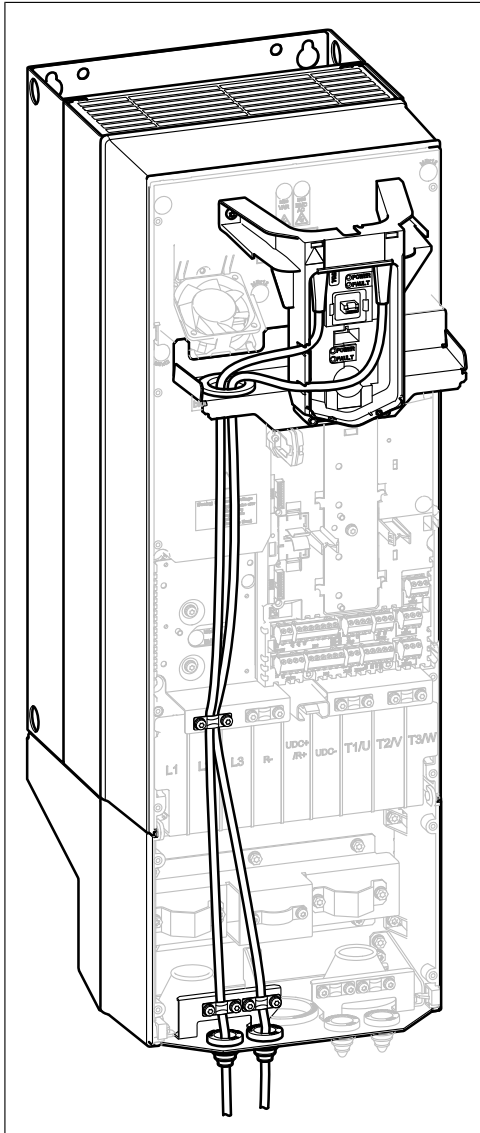

Installing option modules

Note: In frames R1 and R2, 90° connector cannot be used in Slot 1. In other frames, there is 50...55 mm free space for the connector and its cable available on Slots 1, 2 and 3.

For frames R1...R3: Pull the control panel mounting platform upwards to gain access to the optional module slots.

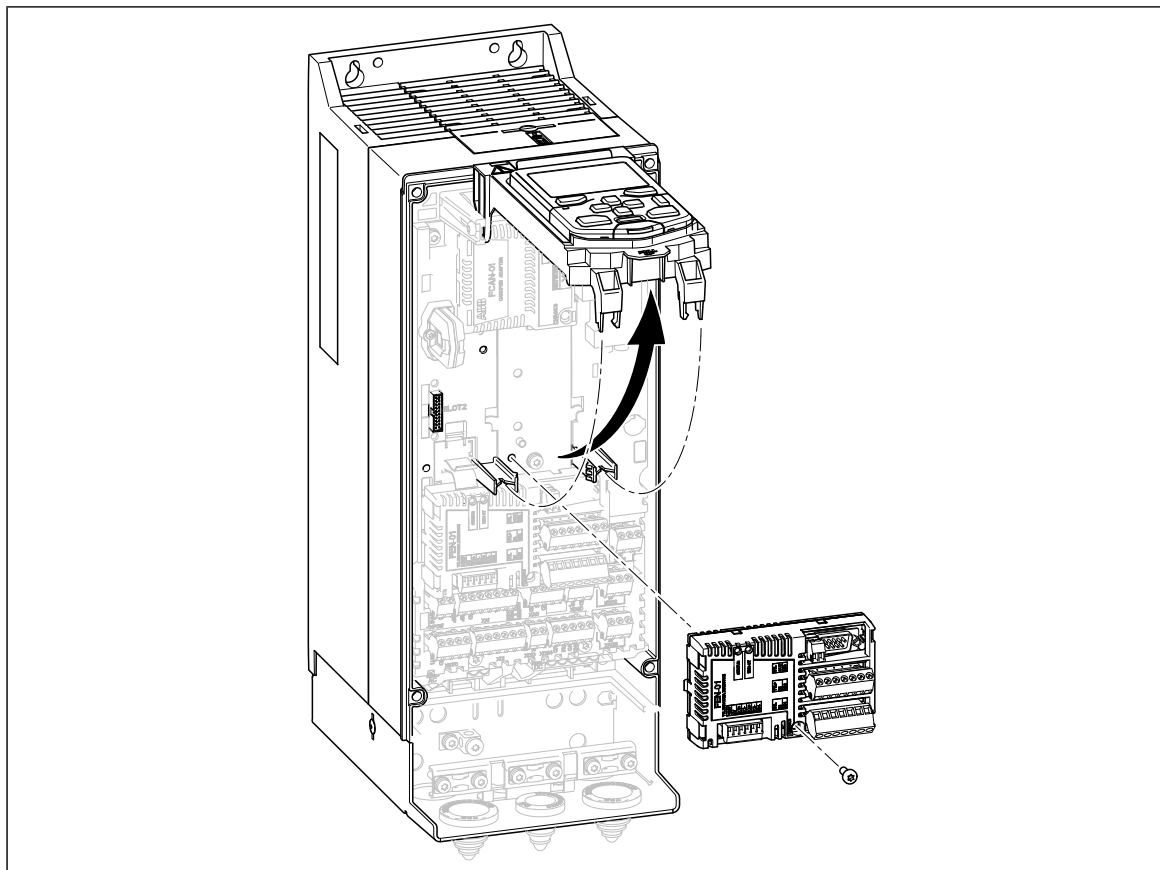

WARNING!

Obey the safety instructions of the drive. If you ignore them, injury or death, or damage to the equipment can occur.

Pay attention to the free space required by the cabling or terminals coming to the option modules.

1. Repeat the steps described in *Electrical safety precautions (page 15)*.
2. Pull out the lock.

Note: The location of the lock depends on the module type.

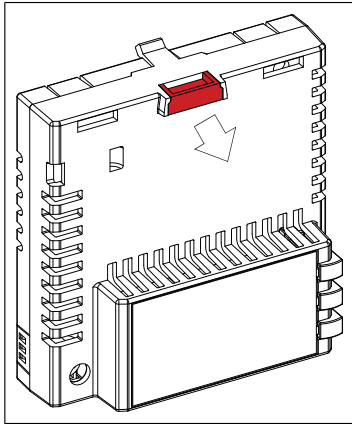

3. Install the module to a free option module slot on the control unit.
4. Push in the lock.

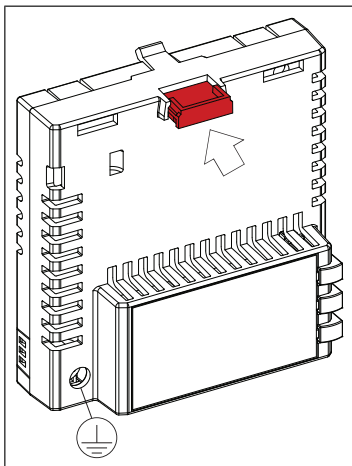

5. Tighten the grounding screw to a torque of 0.8 N·m (7 lbf·in).

Note: The screw tightens the connections and grounds the module. It is essential for fulfilling the EMC requirements and for proper operation of the module.



WARNING!

Do not use excessive force, or leave the screw too loose. Over-tightening can damage the screw or module. A loose screw can cause an operation failure.

6. Connect the wiring to the module. Obey the instructions given in the documentation of the module.

■ **Installing FSO-xx safety functions modules**

The safety functions module can be mounted onto Slot 2 on the control unit or, in frames R7...R9, also next to the control unit.



Installation procedure



WARNING!

Obey the safety instructions of the drive. If you ignore them, injury or death, or damage to the equipment can occur.

1. Repeat the steps described in *Electrical safety precautions (page 15)*.
2. Remove the front cover. See section *Connecting the power cables (page 86)*.
3. Insert the module carefully into its position on the control unit or on its place next to the control unit.
4. Attach the module with four screws. Note: The grounding screw (a) is essential for fulfilling the EMC requirements and for proper operation of the module.
5. Tighten the grounding screw of the electronics to 0.8 N·m.
6. Connect the data communication cable to slot X110 on the module and to connector X12 on the drive control unit.
7. Connect the Safe torque off wires to connector X111 on the module and to connector XSTO on the drive module control unit.
8. Connect the external +24 V power supply cable to connector X112
9. Connect the other wires as shown in *FSO-12 safety functions module user's manual (3AXD50000015612 [English])* or in *FSO-21 safety functions module user's manual (3AXD50000015614 [English])*.

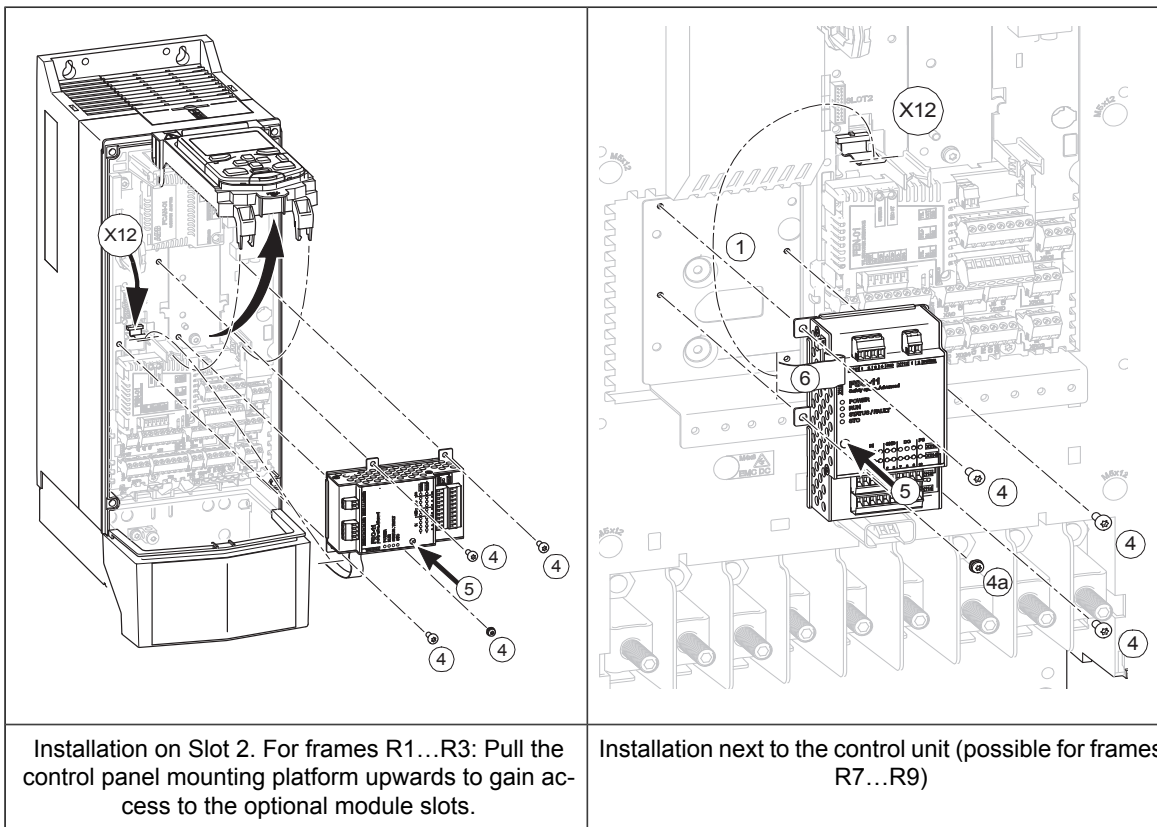

7

Electrical installation – North America

Contents of this chapter

This chapter gives instructions on wiring the drive.

Safety



WARNING!

If you are not a qualified electrical professional, do not do installation or maintenance work. Obey the safety instructions of the drive. If you ignore them, injury or death, or damage to the equipment can occur.

Required tools

To do the electrical installation, you need the these tools:

- wire stripper
- screwdriver set (Torx, flat and/or Phillips, as appropriate)
- torque wrench.

Measuring the insulation

Measuring the insulation is typically not required in North American installations. If measuring is needed, see the instructions in chapter [Measuring the insulation \(page 84\)](#).

Grounding system compatibility check

The standard drive can be installed to a symmetrically grounded TN-S system. If you install the drive to another system, you may need to disconnect the EMC filter and ground-to-phase



varistor. See ACS880 frames R1 to R11 EMC filter and ground-to-phase varistor disconnecting instructions ([3AUA0000125152](#) [English]).



WARNING! Do not install the drive with EMC filter options +E200 or +E202 connected to a system that the filter is not suitable for. This can cause danger, or damage the drive.



WARNING! Do not install the drive with the ground-to-phase varistor connected to a system that the varistor is not suitable for. If you do, the varistor circuit can be damaged.

■ **Corner-grounded and midpoint-grounded 525...690 V delta systems**



WARNING! Do not install the drive on a 525...690 V corner-grounded or midpoint-grounded delta system. Disconnecting the EMC filter and ground-to-phase varistor does not prevent damage to the drive.

Connecting the power cables

■ **Connection diagram with conduits**

This diagram shows power cable connections when conduits are used. For connections with shielded cables, see chapter *Electrical installation – IEC (page 83)*.

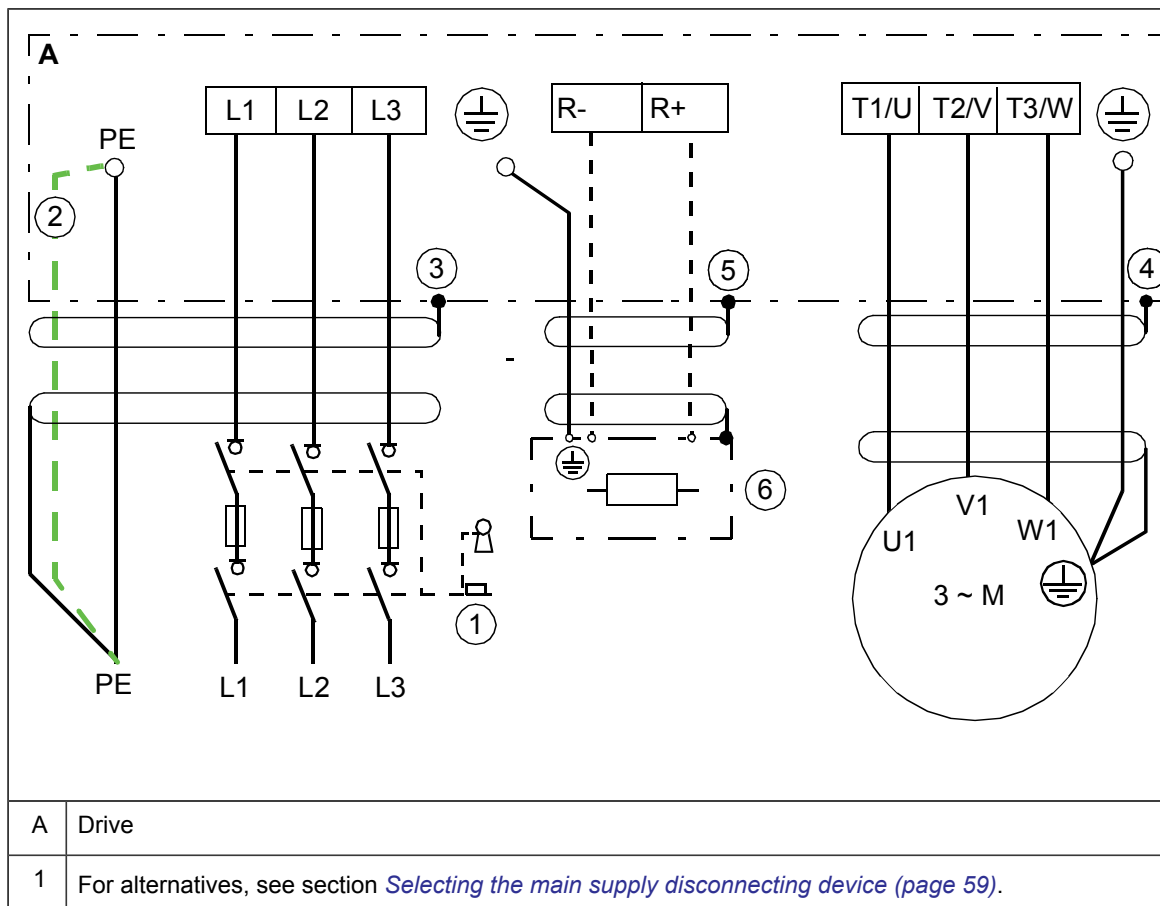

2	<p>Use a separate grounding PE conductor inside the conduit or a grounding cable, if the conductivity of the conduit does not meet the requirements for the PE conductor (see Selecting the power cables (page 65)).</p> <p>Note: If the cross-section of the Cu PE conductor is less than 8 AWG, install a second Cu PE conductor of the same cross-sectional area as the original PE conductor. Alternatively, you can use a Cu PE conductor with at least 10 mm² cross-section. See Selecting the power cables (page 65).</p>
3	<p>Make sure of a correct grounding of the conduit at the cable entry. Ground the other end of the conduit and grounding conductor (if used) at the distribution board.</p>
4	<p>Make sure of a correct grounding of the conduit at the cable entry.</p>
5	<p>Make sure of a correct grounding of the conduit at the cable entry.</p>
6	<p>External brake resistor (if used), see chapter Resistor braking (page 245).</p>
<p>Note: Do not use an asymmetrically constructed motor cable for motors above 30 kW. Connecting its fourth conductor at the motor end increases bearing currents and causes extra wear.</p>	



■ Connection procedure for frames R1 to R3

1. Undo the mounting screws at the sides of the front cover.
2. Remove the cover by sliding it forward.
3. Attach the residual voltage warning sticker in the local language to the control panel mounting platform.
4. Remove the rubber grommets from the entry plate for the cables to be connected.
5. Fasten the cable conduits to the cable lead-through plate holes. Strip the cable ends. Slide the cables through the connectors.
6. Connect the grounding conductors to the grounding terminals.
7. Connect the phase conductors of the input and motor cables. Tighten the screws.
8. Drives with option +D150: Connect the brake resistor cable conductors to the R+ and R- terminals.
9. Install the control cable grounding shelf in the cable entry box.
10. Connect the motor cable at the motor end.

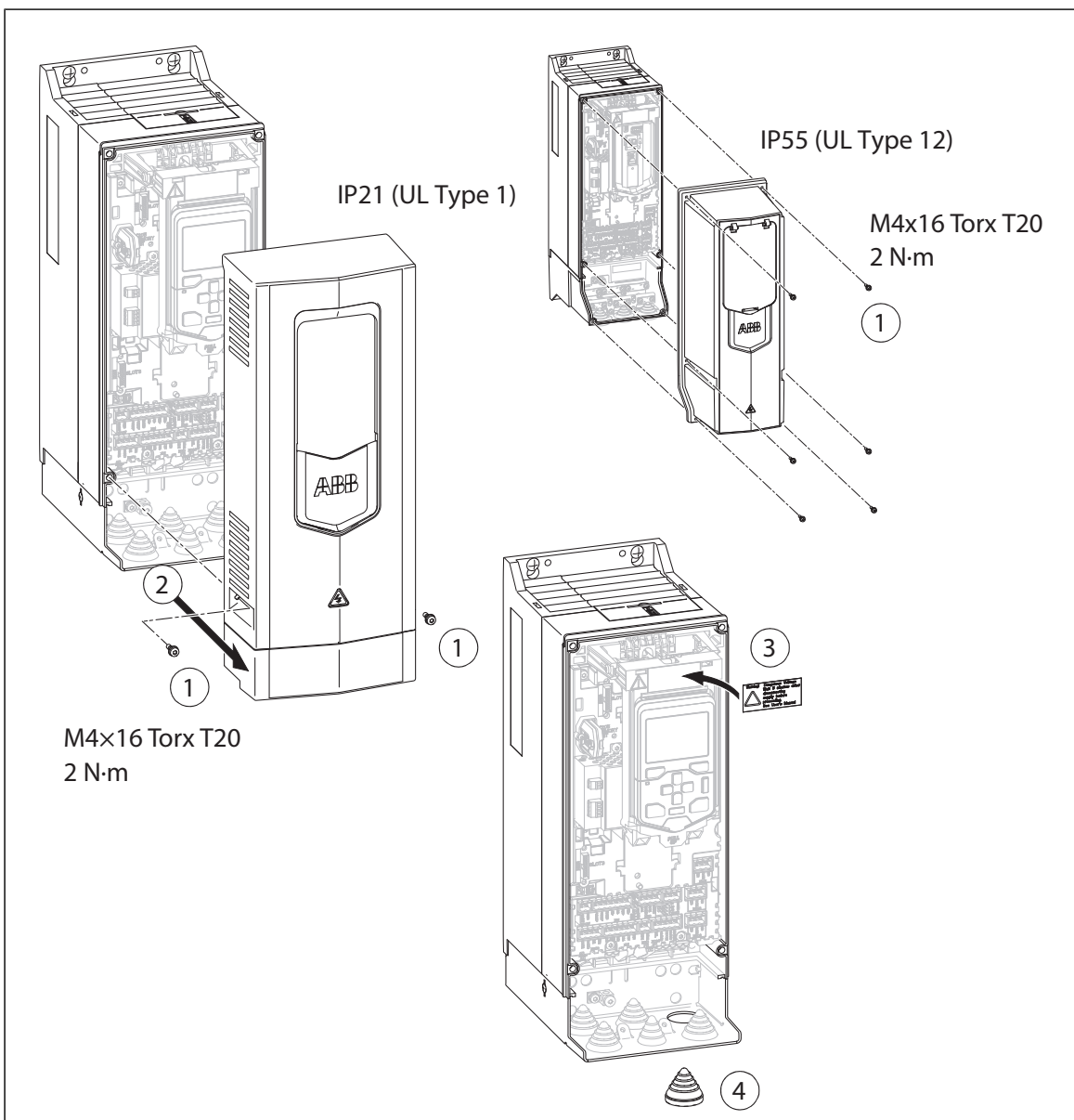

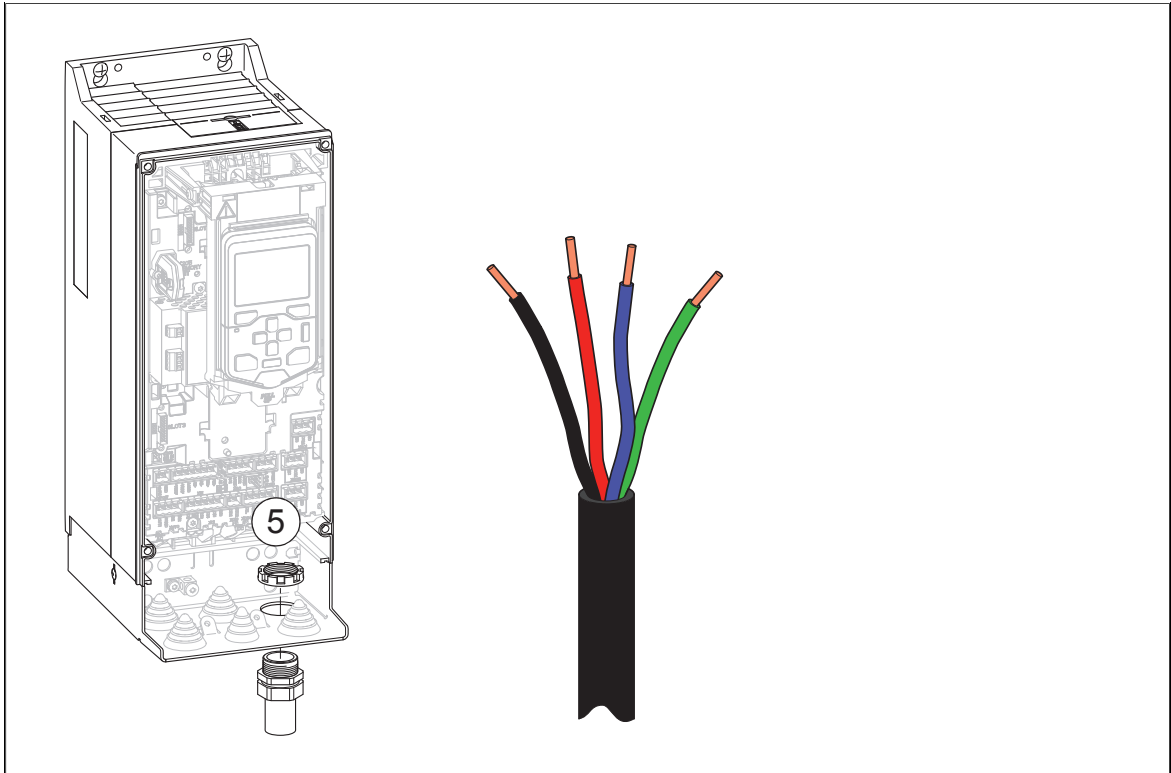

	L1, L2, L3, T1/U, T2/V, T3/W, R-, R+/ UDC+, UDC (lbf·ft)	 (lbf·ft)
R1	0.4	1.3
R2	0.4	1.3
R3	1.3	1.3



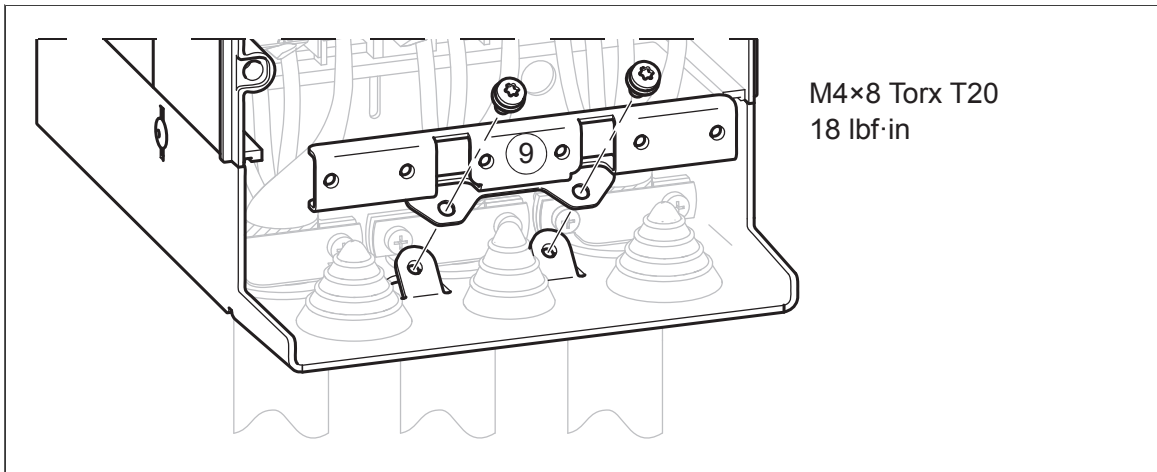

■ Connection procedure for frames R4 and R5

In this connection procedure, the cables are connected to the power cable connectors. For cable lug installation of frame R5, see also chapter *Electrical installation – IEC (page 83)* and section *UL listed cable lugs and tools (page 212)*.

1. Remove the front cover. UL Type 1 units: Release the retaining clip with a screwdriver (a) and lift the cover from the bottom outwards (b). Remove the cable entry box cover by undoing the mounting screw.
2. Attach the residual voltage warning sticker in the local language next to the control board top.
3. Remove the shroud on the power cable terminals by releasing the clips and lifting the shroud up from the sides with a screwdriver (a). Knock out holes in the shroud for the cables to be installed (b). Remove the EMC shroud that separates the input and output cabling if needed for easier installation (see drawing of point 9).
4. Remove the control cable grounding shelf which is needed for EU cabling.
5. Remove the power cable grounding clamps which are needed for EU cabling.
6. Attach the cable conduits to the cable lead-through plate holes. Strip the cable ends. Slide the cables through the connectors.
7. Twist the grounding wires and connect them to the grounding terminals.
8. Connect the conductors of the input and motor cables. Tighten the screws.
9. Install the EMC shroud separating the input and output cabling if not installed yet.
10. Drives with option +D150: Connect the conductors of the brake resistor cable to the R+ and R- terminals.
11. Reinstall the shroud on the power cable terminals.
12. Connect the motor cable at the motor end.



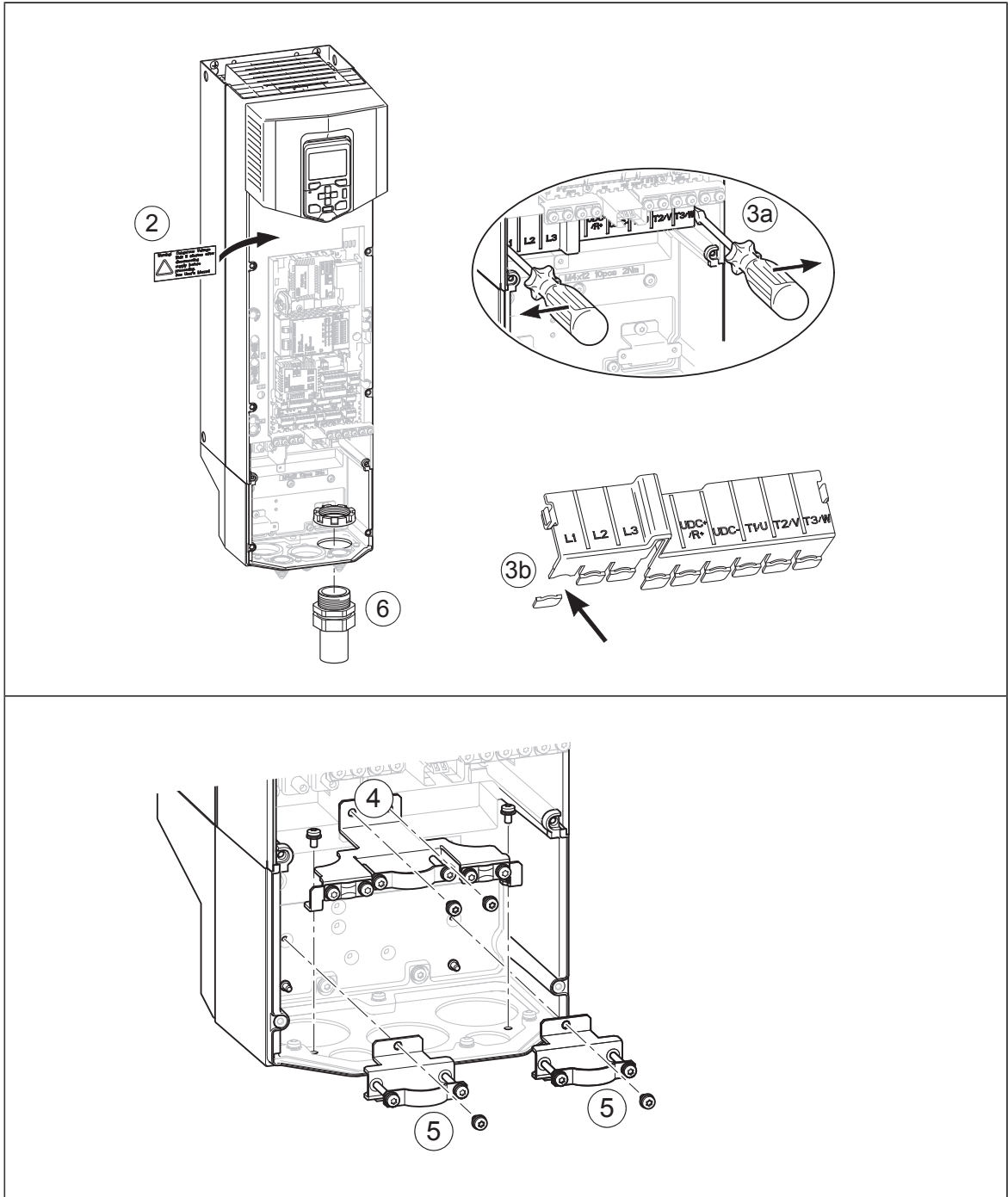

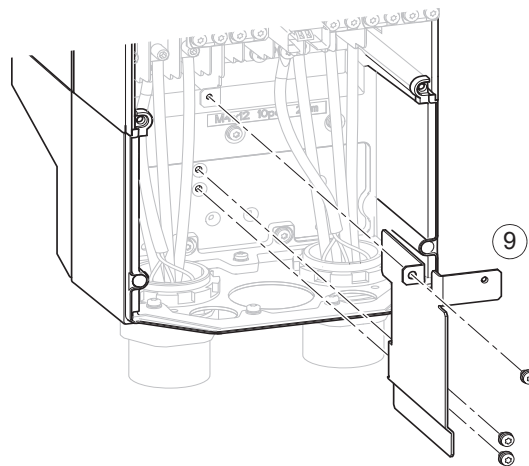
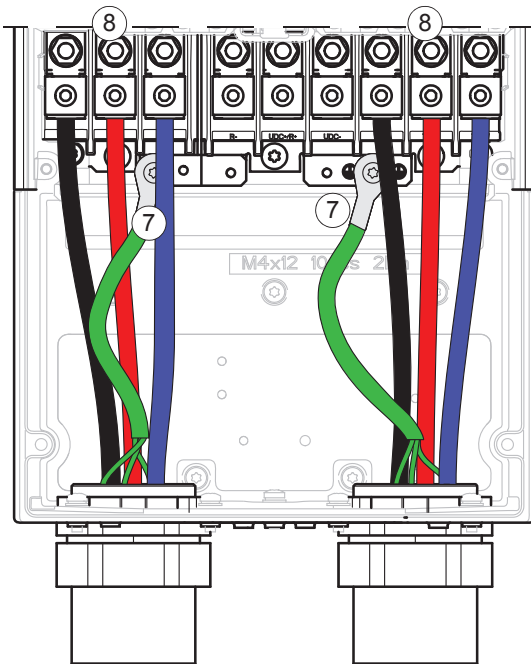
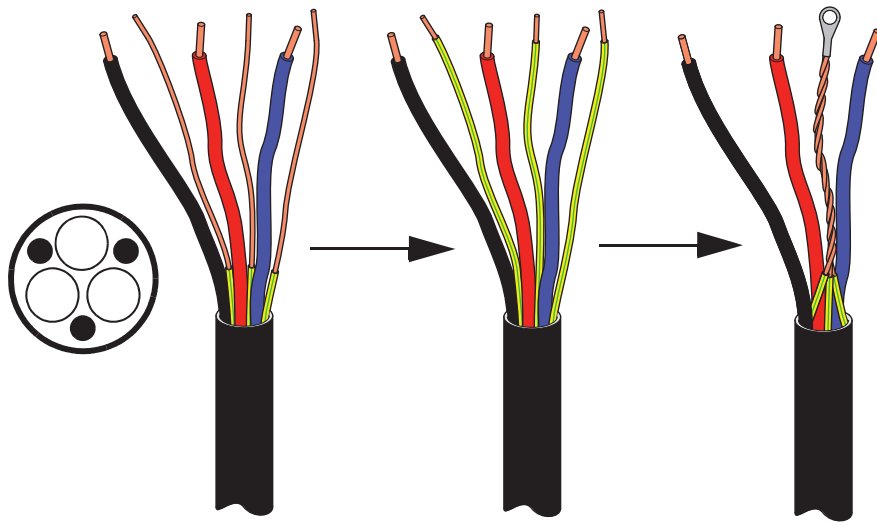

R4: M4×8 Torx T20 (2 pcs),
M4×10 Torx T20 (1 pcs)
2 N·m
R5: M4×8 Torx T20
2 N·m

	L1, L2, L3, T1/U, T2/V, T3/W, R-, R+/UDC+, UDC-	
	(lbf·ft)	(lbf·ft)
R4	2.4	2.1
R5	4.1	2.1



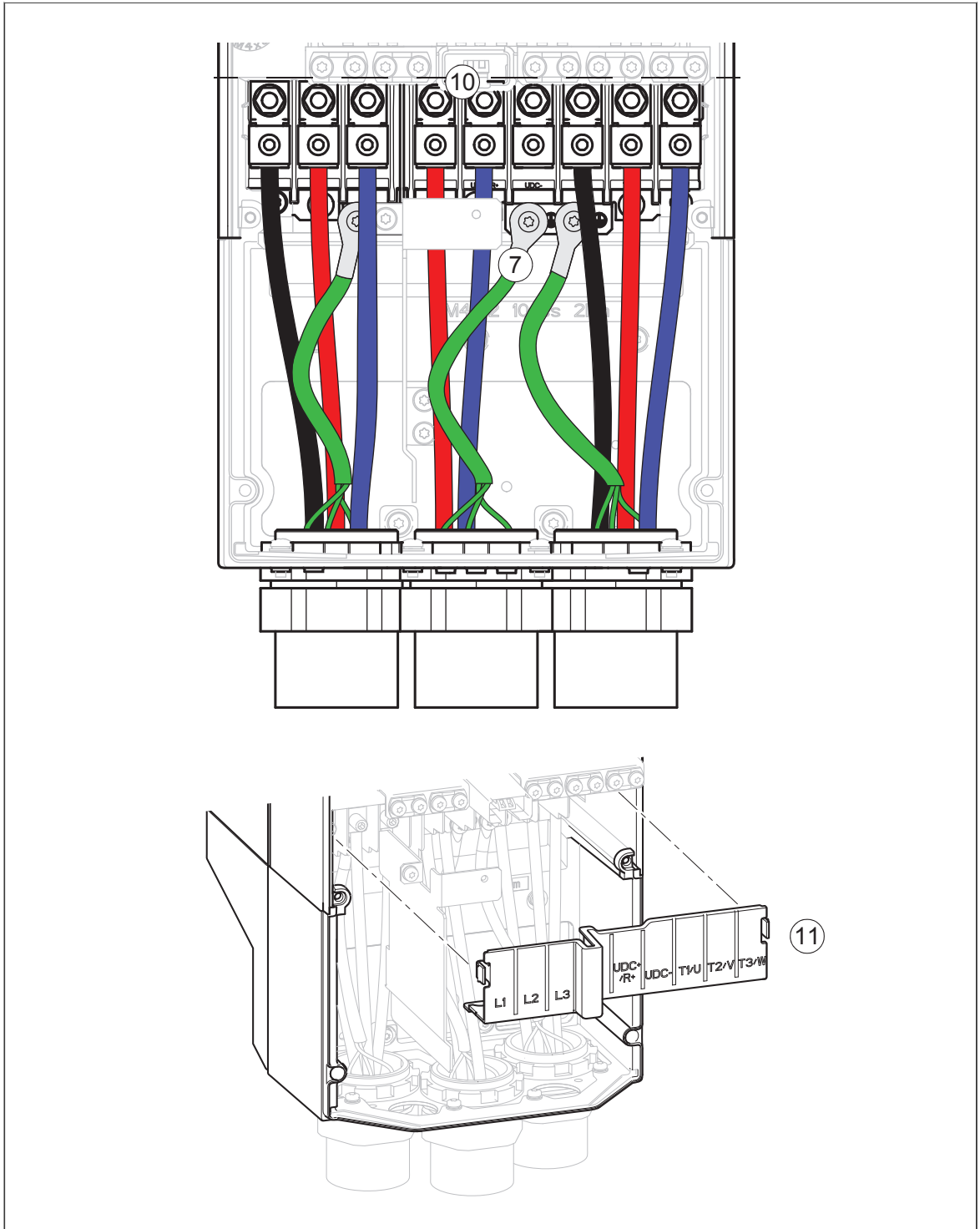

■ Connection procedure for frames R6 to R9

In this connection procedure, the cables are connected to the power cable connectors. For cable lug installation, see also chapter *Electrical installation – IEC (page 83)* and section *UL listed cable lugs and tools (page 212)*.

Use symmetrical shielded cable for the motor cabling.

1. Remove the front cover: UL Type 1 drives: Release the retaining clip with a screwdriver (a) and pull the cover by the bottom outwards (b).
2. UL Type 1 drives: Remove the cable entry box cover by undoing the mounting screws.
3. Attach the residual voltage warning sticker in the local language next to the control board top.
4. Remove the side plates of the cable entry box.
5. Remove the shroud on the power cable terminals by releasing the clips on the sides with a screwdriver and lifting (a). If parallel cables are installed, knock out holes for the cables (b).
6. Knock out the shrouds on the power cable terminals for the cables to be installed..
7. Fasten the cable conduits to the cable lead-through plate holes. Strip the cable ends. Slide the cables through the connectors.
8. Twist grounding wires and connect them to the grounding terminals.
9. Connect the conductors of the input and motor cables. Tighten the screws.
10. Drives with option +D150: Connect the conductors of the brake resistor cable to the R+ and R- terminals.
11. Reinstall the shroud on the power terminals.
12. Reinstall the side plates of the cable entry box.



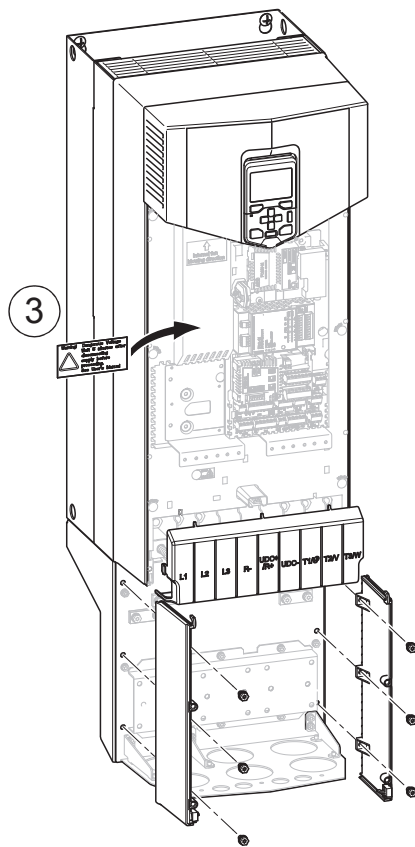

4 **R6,R7,R9:** M5×12 Torx T20
R8: M5×20 Torx T20
2 N·m (17 lbf·in)

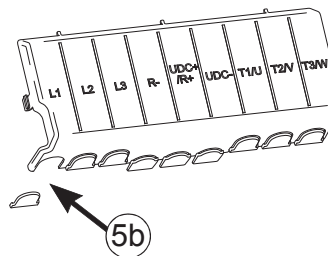
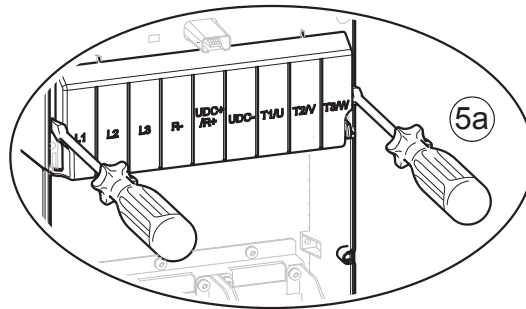

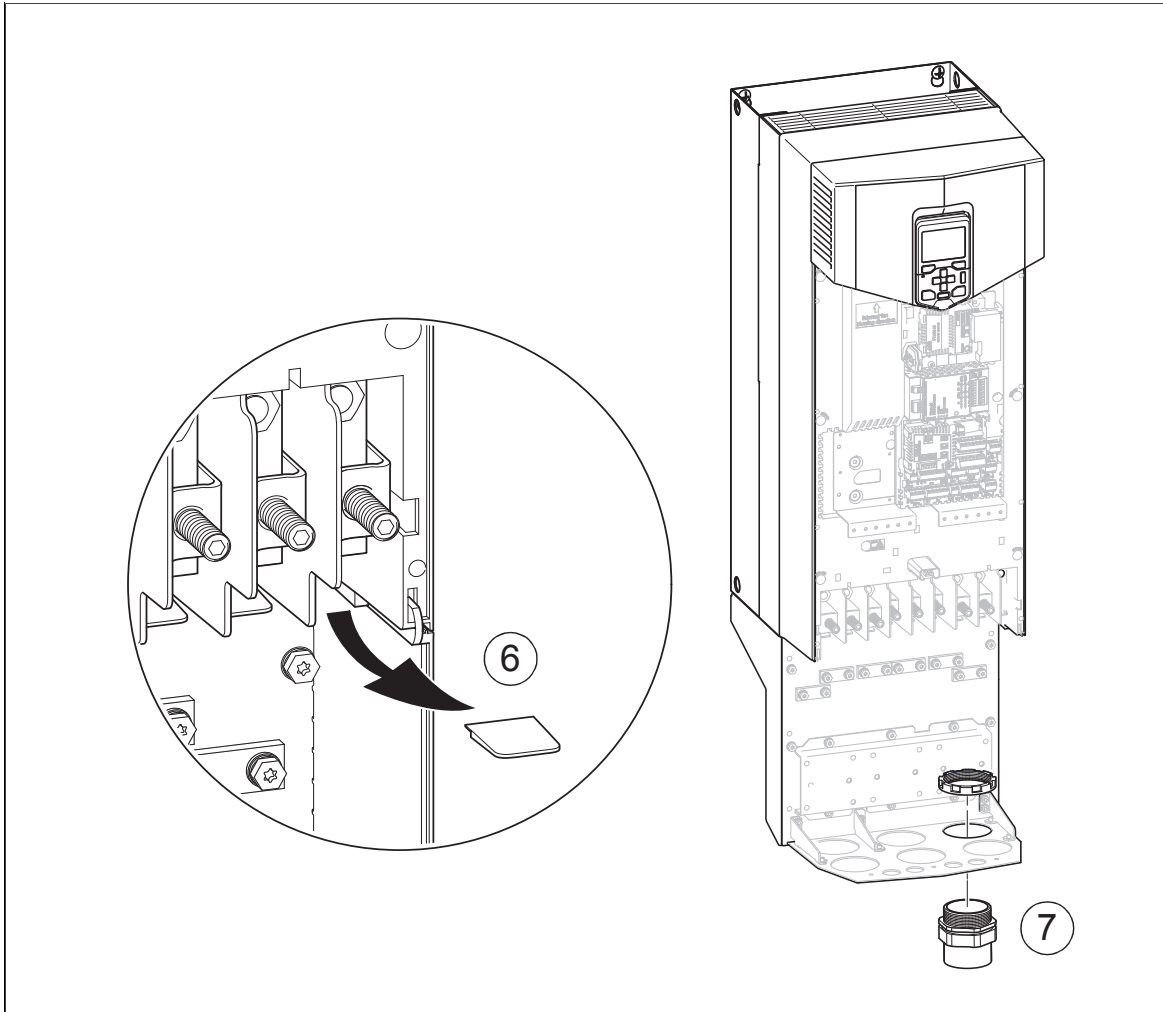

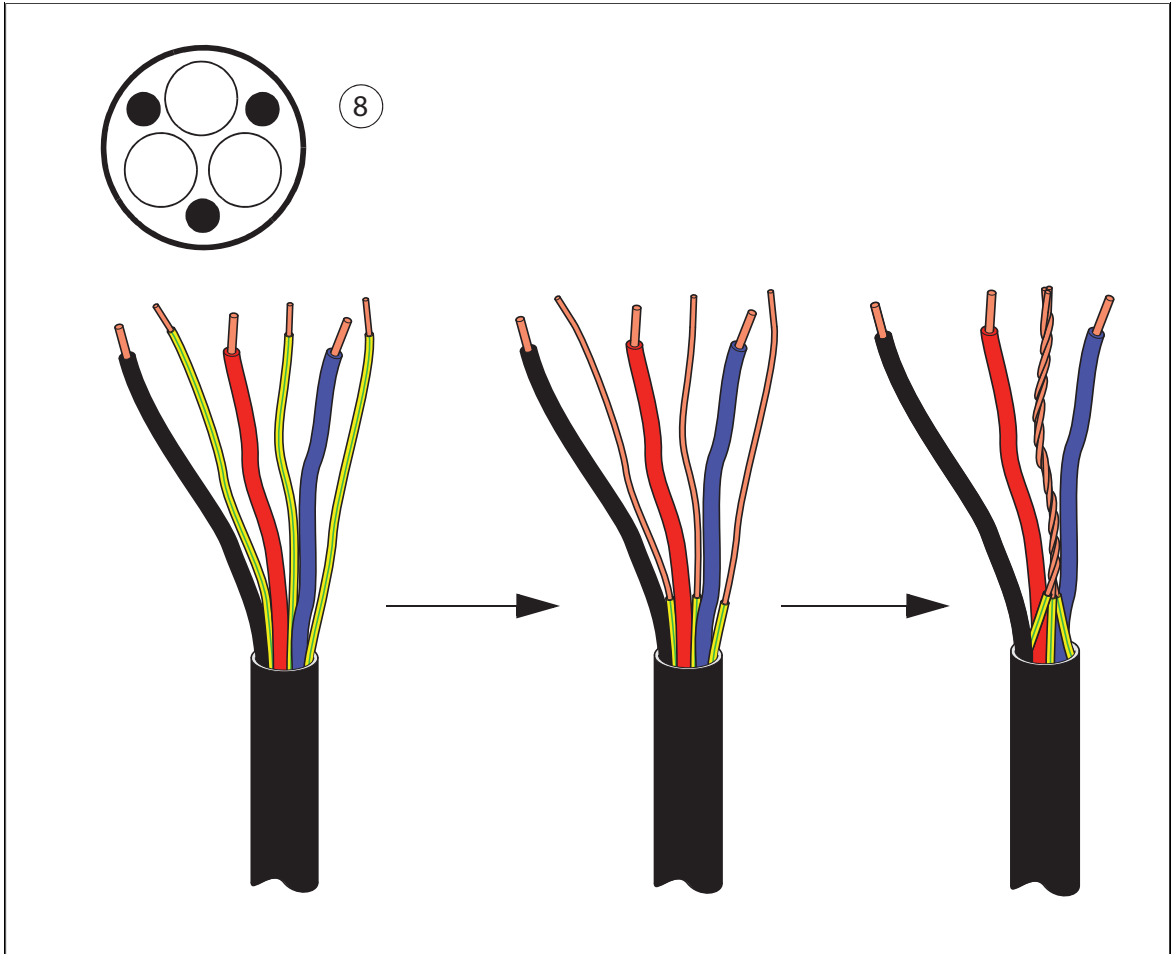

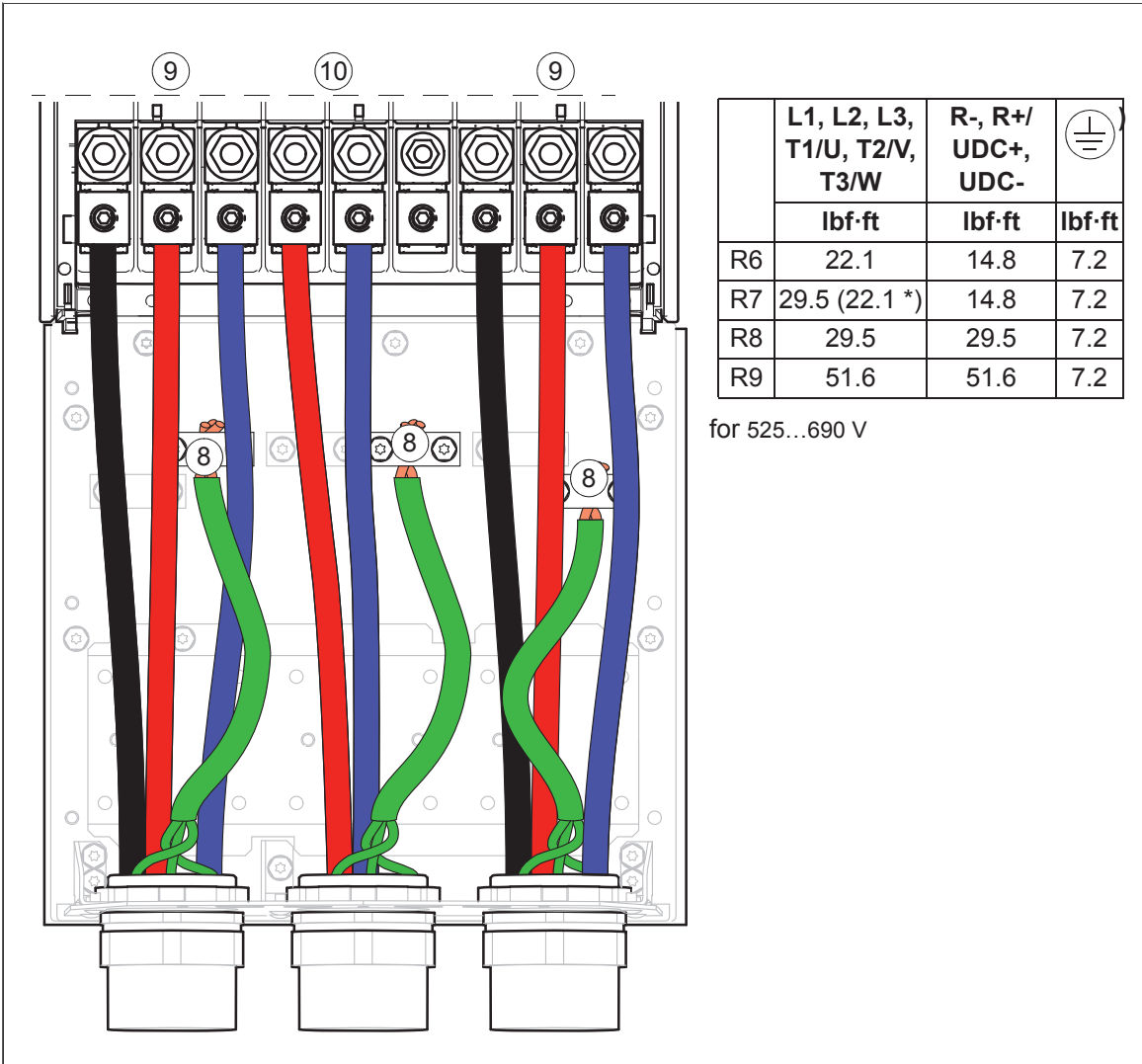

Connecting the control cables

See section [Control units of the drive \(page 135\)](#) for the default I/O connections of the Factory macro of ACS880 primary control program. For other macros and control programs, see the firmware manual.

■ Connection procedure for frames R1 to R3

1. Fasten the cable conduits to the cable lead-through plate holes. Slide the cables through the connectors.
2. Strip the cable ends and cut to suitable length (note the extra length of the grounding conductors).
3. Ground the outer shields of all control cables 360 degrees at a grounding clamp in the cable entry box.
4. Ground the pair-cable shields to the grounding clamp. Leave the other end of the shields unconnected or ground them indirectly via a high-frequency capacitor with a few nanofarads, eg, 3.3 nF / 630 V.
5. Connect the conductors to the appropriate terminals of the control board.

6. Wire the optional modules if included in the delivery. For connecting the fieldbus cables, see *ACS880-01 quick installation guide for frames R1 to R3* ([3AUJA0000099689](https://www.aegiautomation.com/acs880-01-quick-installation-guide-for-frames-r1-to-r3) [English]).
7. Reinstall the front cover.

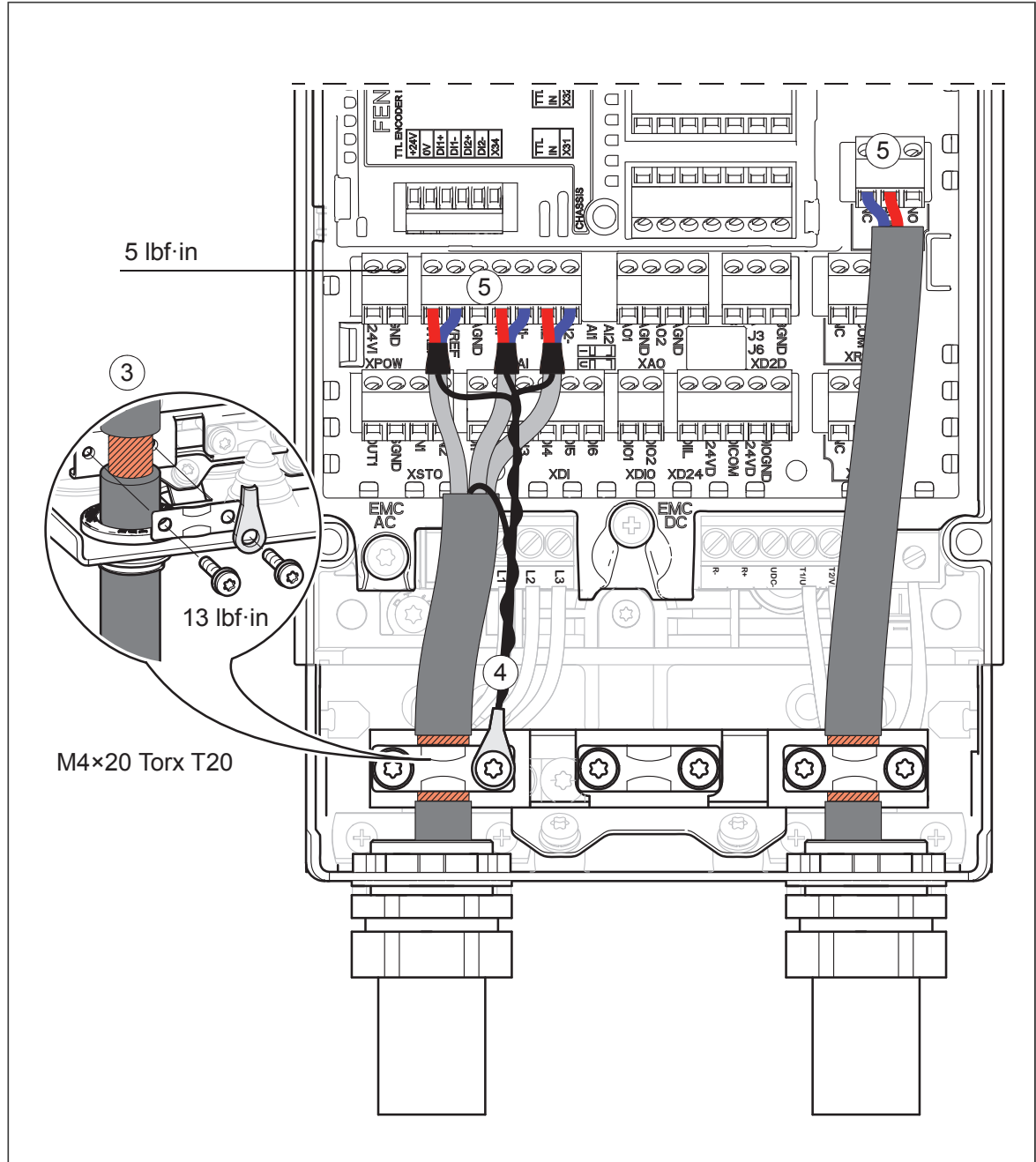

■ **Connection procedure for frames R4 to R5**

1. Fasten the cable conduits to the cable lead-through plate holes. Slide the cables through the connectors.
2. Strip the cable ends and cut to suitable length (note the extra length of the grounding conductors).
3. Ground the pair-cable shields to a grounding clamp below the control board. Leave the other end of the shields unconnected or ground them indirectly via a high-frequency capacitor with a few nanofarads, eg, 3.3 nF / 630 V.

4. Connect the conductors to the appropriate terminals of the control board.
5. Wire the optional modules if included in the delivery. For connecting the fieldbus cables, see *ACS880-01 quick installation guide for frames R4 and R5* ([3AUA0000085966](https://www.aegiautomation.com/acs880-01-quick-installation-guide-for-frames-r4-and-r5-3AUA0000085966) [English]).
6. Reinstall the front covers.

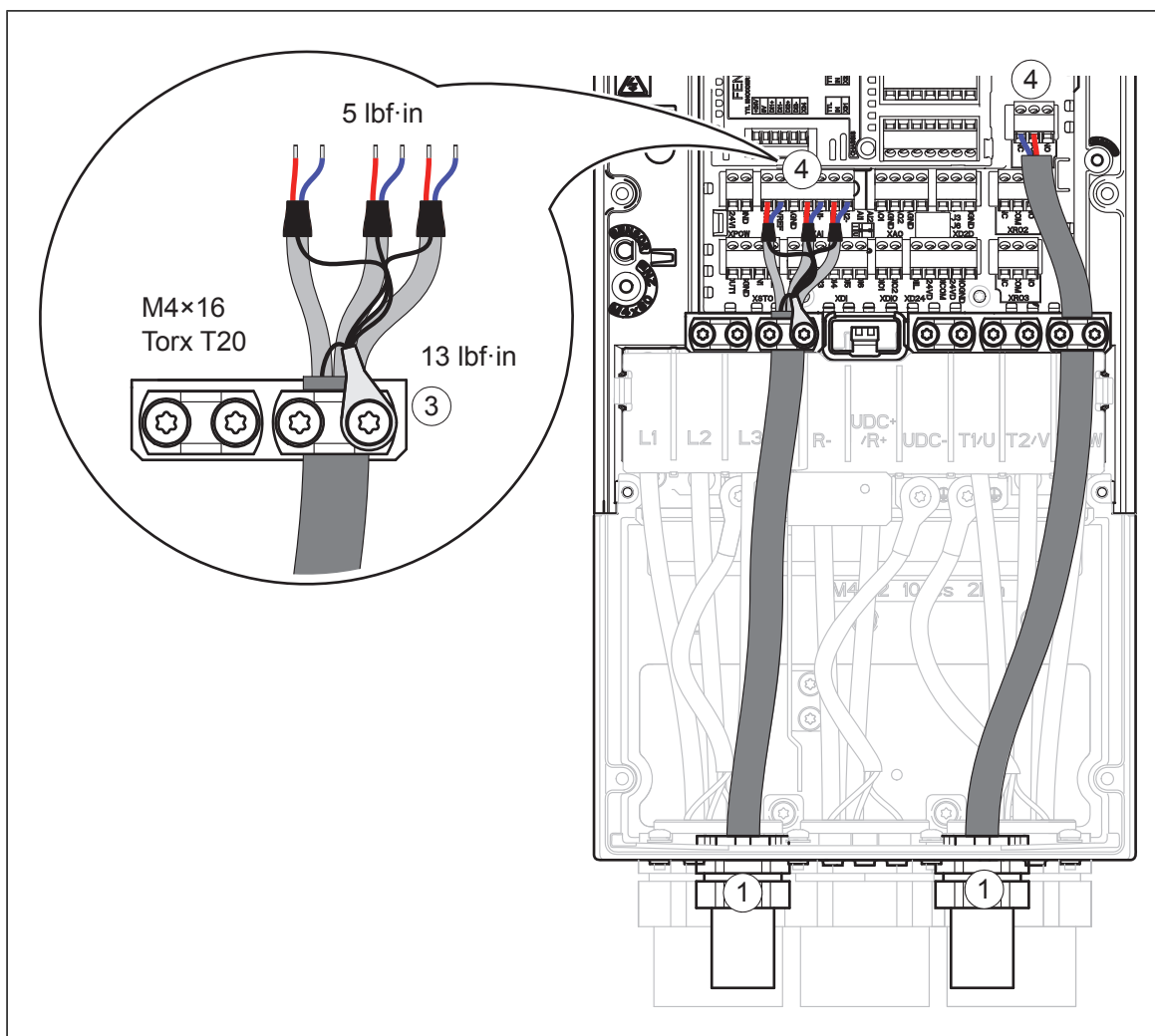

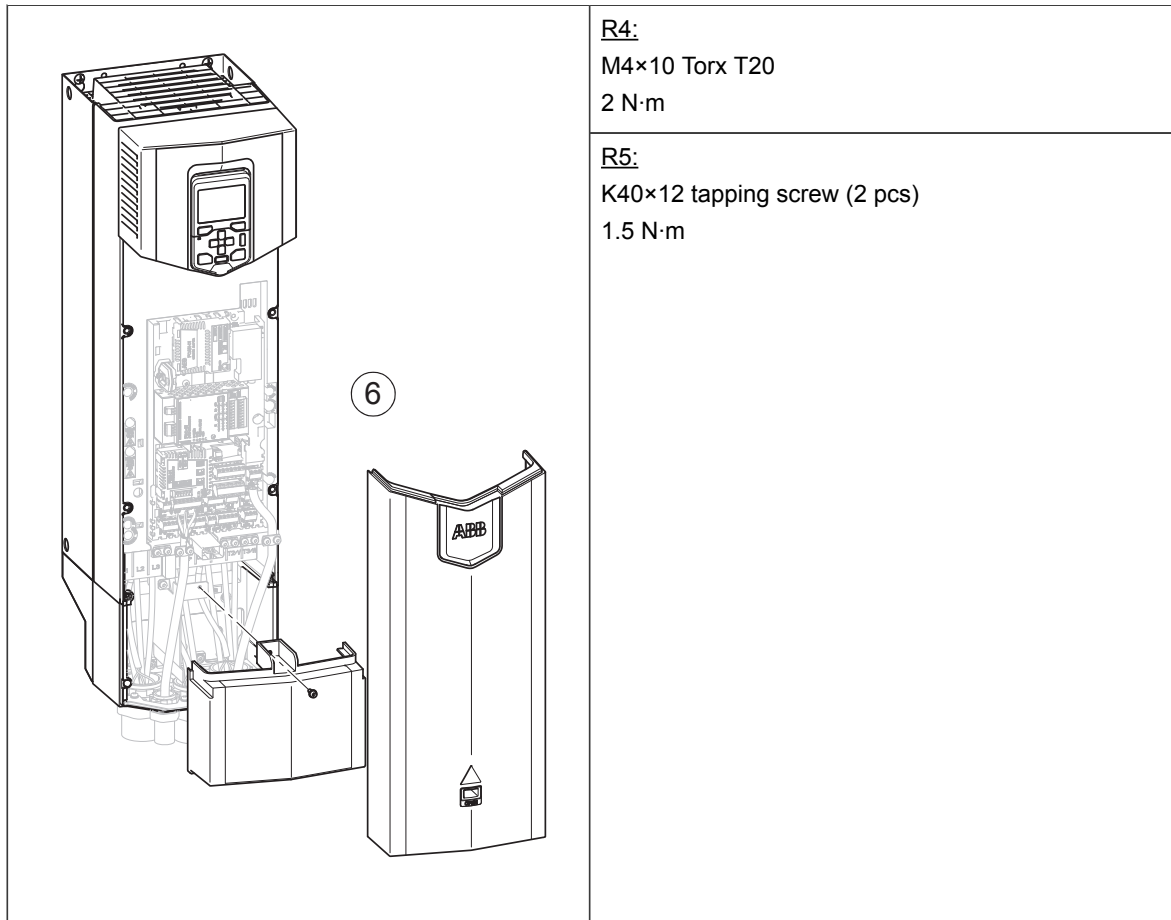

■ Connection procedure for frames R6 to R9

Install the control cable grounding shelf in the cable entry box.

1. Fasten the cable conduits to the cable lead-through plate holes. Slide the cables through the connectors.
2. Strip the cable ends and cut to suitable length (note the extra length of the grounding conductors).
3. Ground the outer shields of all control cables 360 degrees at a grounding clamp in the cable entry box.
4. Ground the pair-cable shields to a grounding clamp below the control board. Leave the other end of the shields unconnected or ground them indirectly via a high-frequency capacitor with a few nanofarads, eg, 3.3 nF / 630 V.
5. Connect the conductors to the appropriate terminals of the control board.
6. Wire the optional modules if included in the delivery. For connecting the fieldbus cables, see *ACS880-01 quick installation guide for frames R6 to R9* ([3AJA0000099689](https://www.abb.com/global/scad/3AJA0000099689) [English]).
7. Reinstall the front covers.



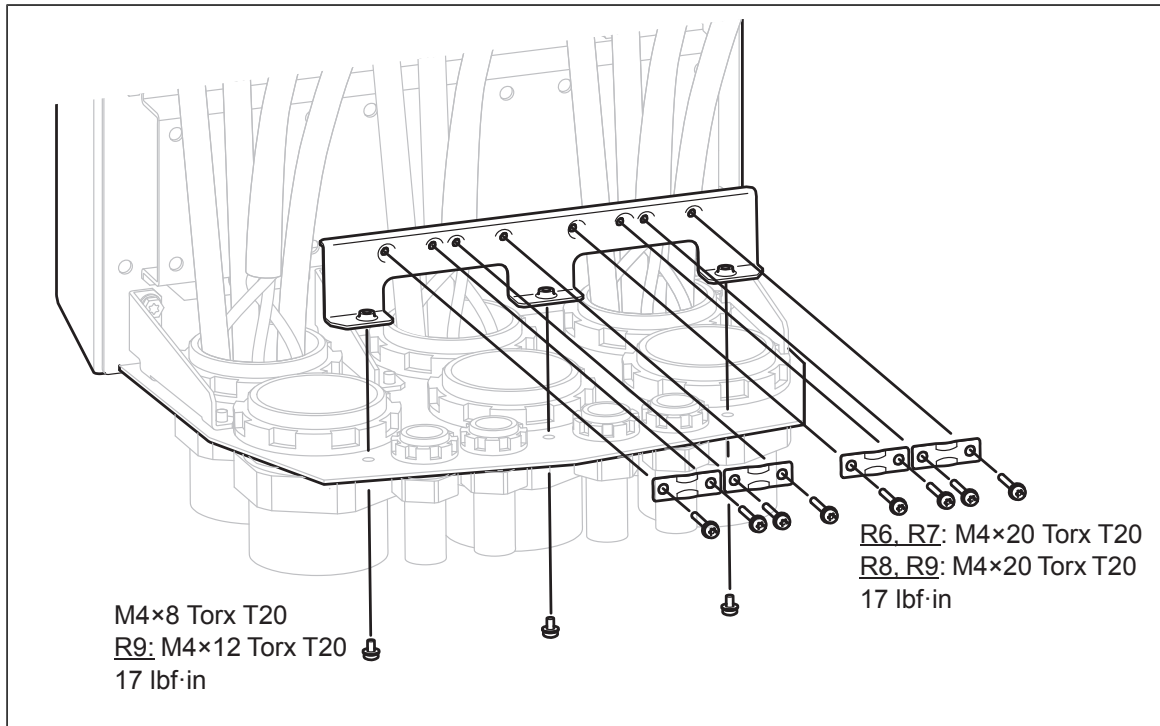

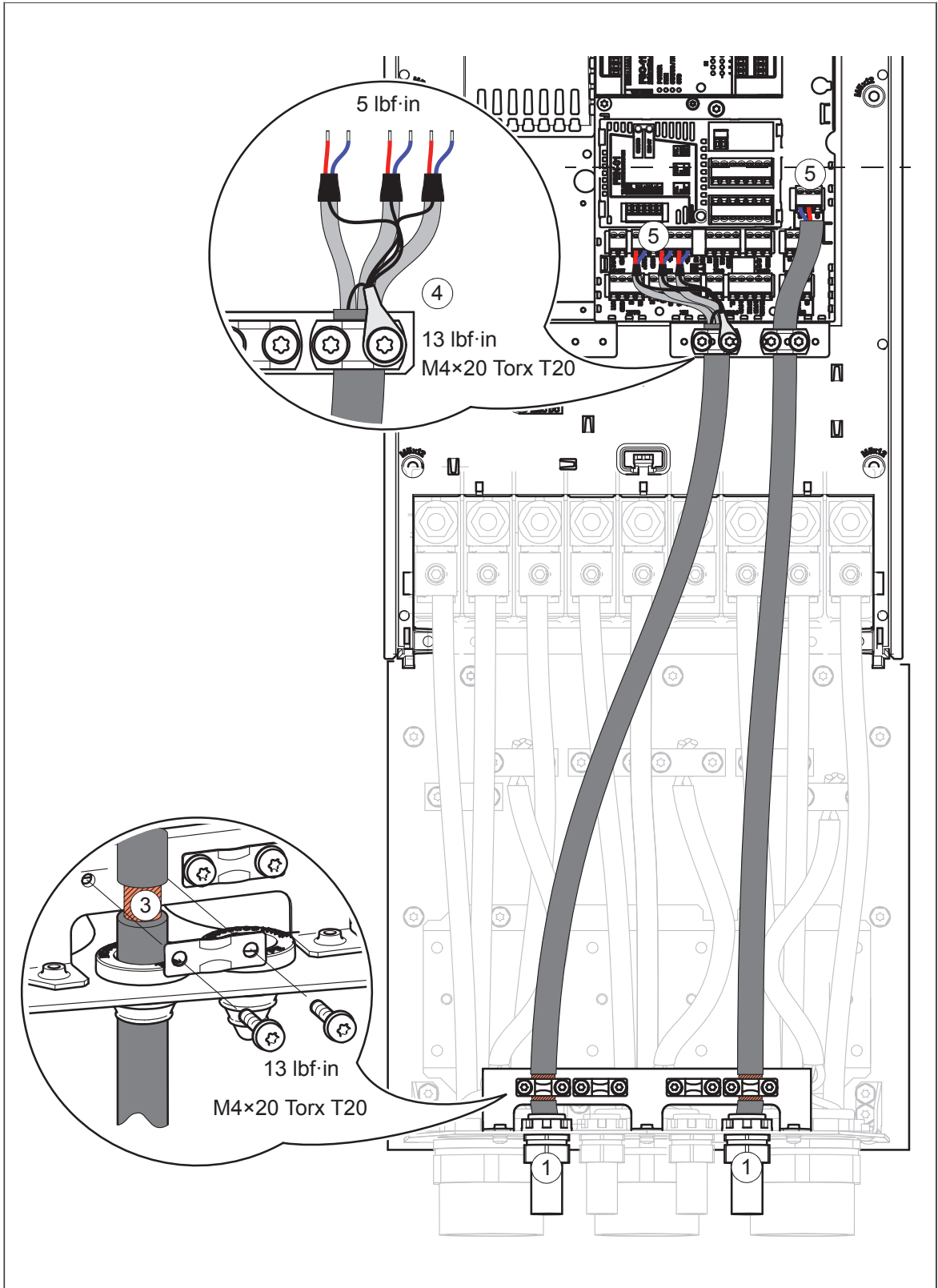

Connecting a PC



WARNING!

Do not connect the PC directly to the control panel connector of the control unit as this can cause damage.

A PC (with eg, the Drive composer PC tool) can be connected as follows:

1. Connect an ACx-AP-x control panel to the unit either
 - by inserting the control panel into the panel holder or platform, or
 - by using an Ethernet (eg, Cat 5e) networking cable.
2. Remove the USB connector cover on the front of the control panel.
3. Connect an USB cable (Type A to Type Mini-B) between the USB connector on the control panel (3a) and a free USB port on the PC (3b).
4. The panel will display an indication whenever the connection is active.
5. See the documentation of the PC tool for setup instructions.

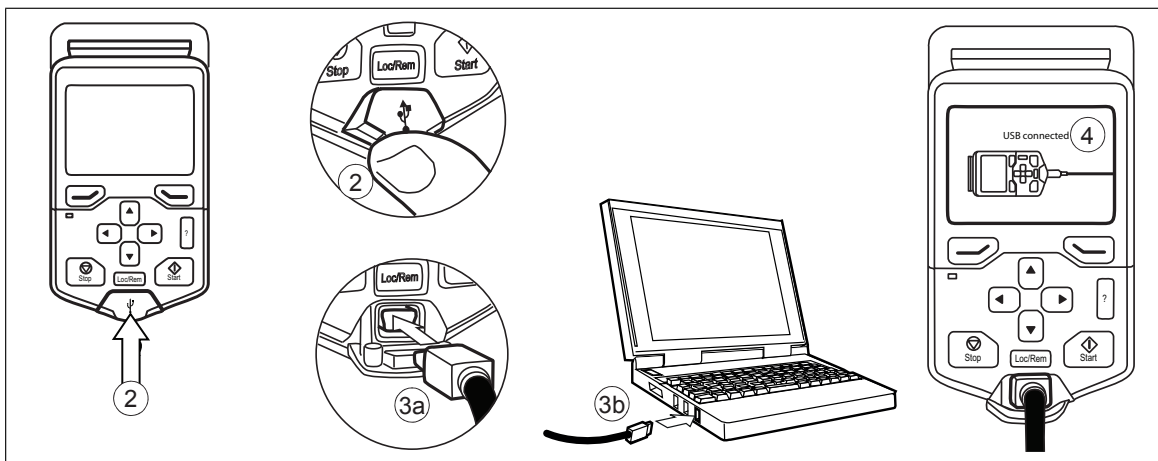

Panel bus (control of several units from one control panel)

One control panel (or PC) can be used to control several drives (or inverter units, supply units etc.) by constructing a panel bus. This is done by daisy-chaining the panel connections of the drives. Some drives have the necessary (twin) panel connectors in the control panel holder; those that do not require the installation of an FDPI-02 module (available separately). For further information, see the hardware description and *FDPI-02 diagnostics and panel interface user's manual* (3AUA0000113618 [English]).

The maximum allowed length of the cable chain is 100 m (328 ft).

1. Connect the panel to one drive using an Ethernet (for example Cat 5e) cable.
 - Use Menu - Settings - Edit texts - Drive to give a descriptive name to the drive
 - Use parameter 49.01* to assign the drive with a unique node ID number
 - Set other parameters in group 49* if necessary
 - Use parameter 49.06* to validate any changes.

*The parameter group is 149 with supply (line-side), brake or DC/DC converter units. Repeat the above for each drive.

2. With the panel connected to one unit, link the units using Ethernet cables.

3. Switch on the bus termination on the drive that is farthest from the control panel in the chain.
 - With drives that have the panel mounted on the front cover, move the terminating switch into the outer position.
 - With an FDPI-02 module, move termination switch S2 into the TERMINATED position.

Make sure that bus termination is off on all other drives.

4. On the control panel, switch on the panel bus functionality (Options - Select drive - Panel bus). The drive to be controlled can now be selected from the list under Options - Select drive.

If a PC is connected to the control panel, the drives on the panel bus are automatically displayed in the Drive composer tool.

With twin connectors in the control panel holder:

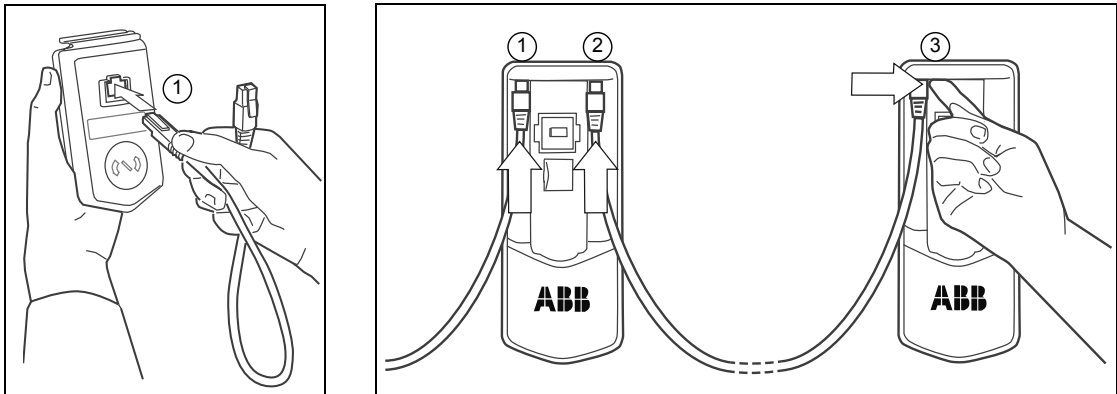

With FDPI-02 modules:

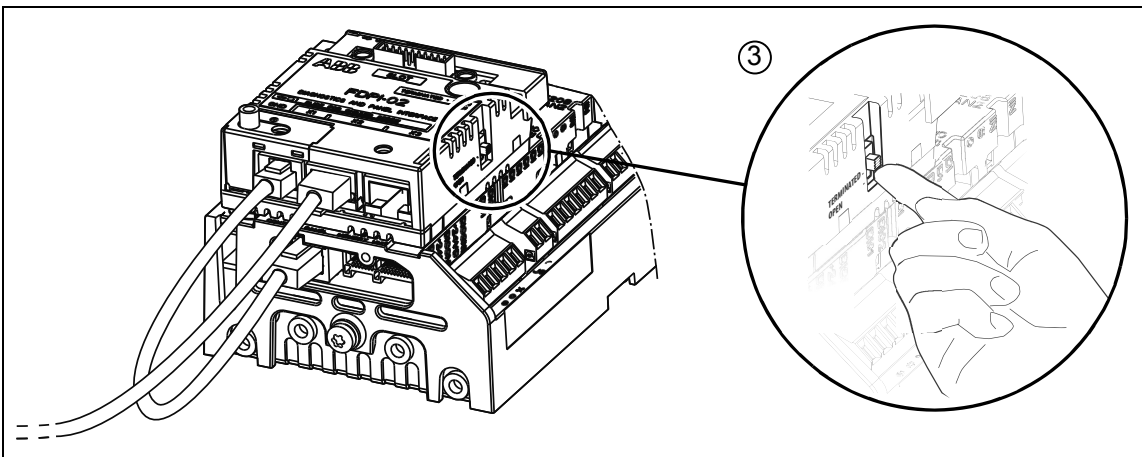
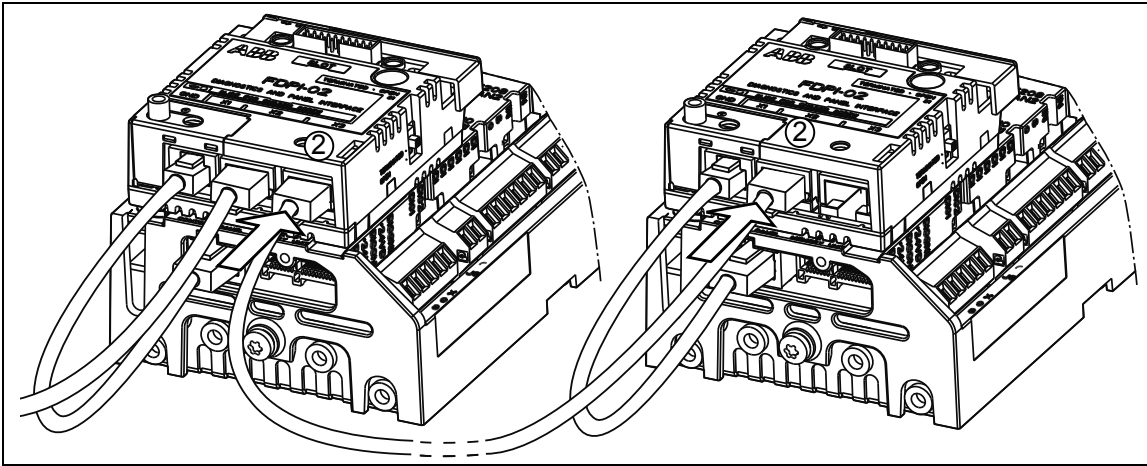
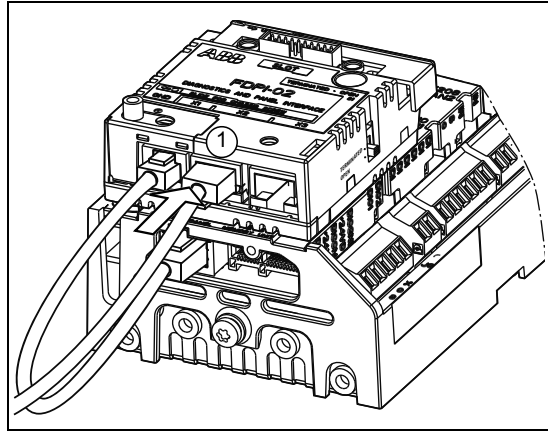
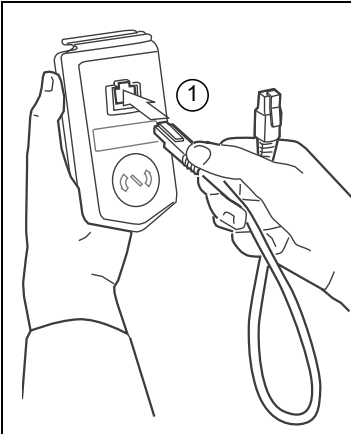

ACS880-01 IP55 (UL Type 12):

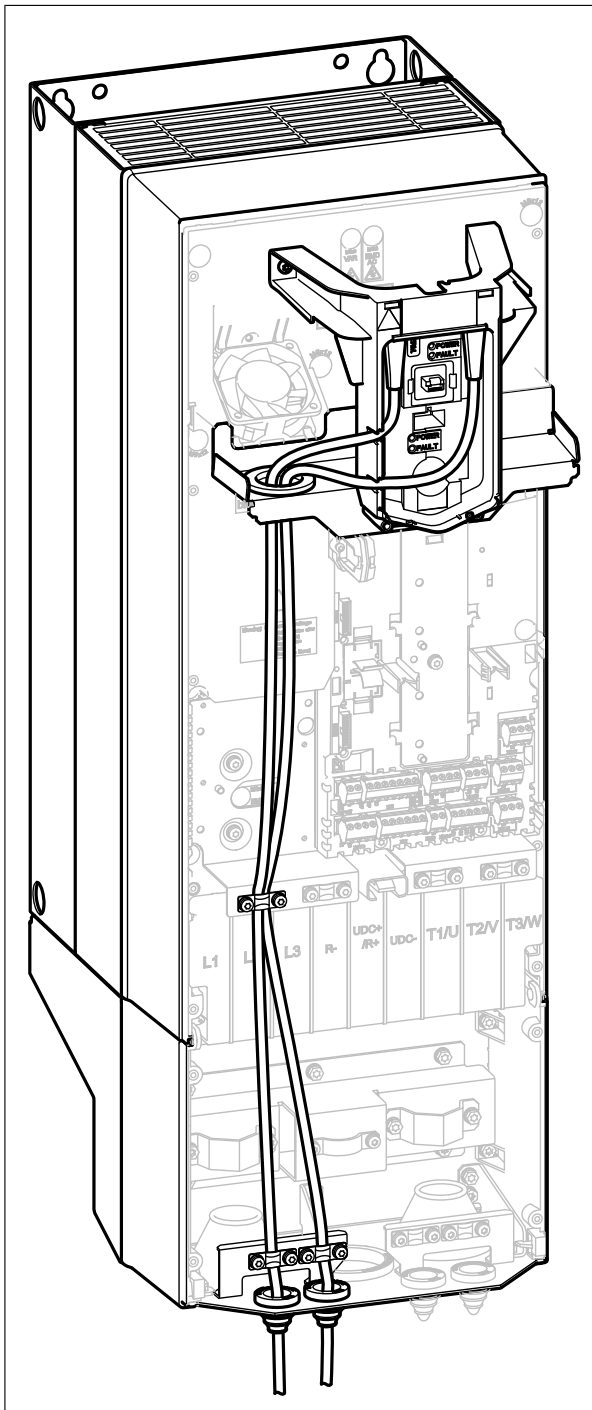

Installing option modules

See section *Installing option modules* (page 108).





Control units of the drive

Contents of this chapter

This chapter

- describes the connections of the control unit(s) used in the drive,
 - contains the specifications of the inputs and outputs of the control unit(s).
-

ZCU-12 layout

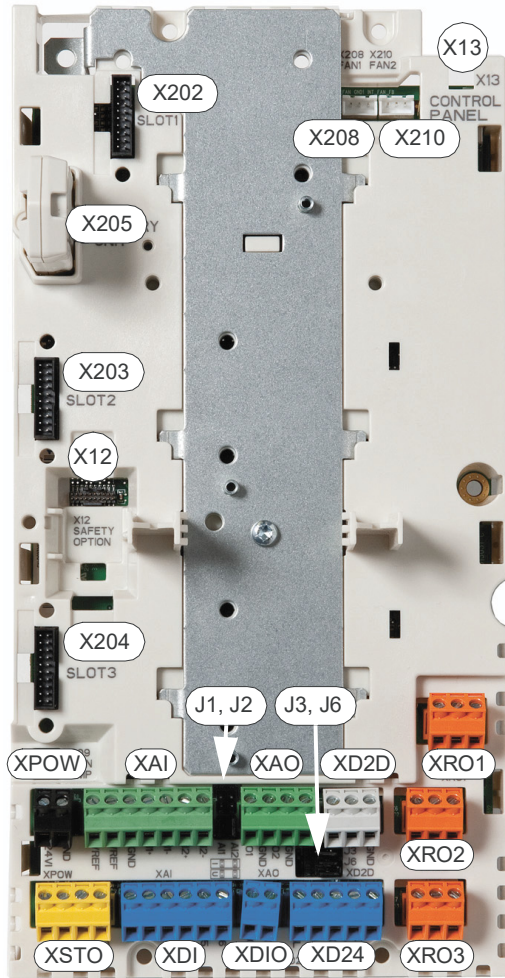

	Description
XAI	Analog inputs
XAO	Analog outputs
XDI	Digital inputs
XDIO	Digital input/outputs
XD24	Digital input interlock (DIIL) and +24 V output
XD2D	Drive-to-drive link
XPOW	External power input
XRO1	Relay output RO1
XRO2	Relay output RO2
XRO3	Relay output RO3
XSTO	Safe torque off connection
X12	Connection for FSO-xx safety functions module
X13	Control panel connection
X202	Option slot 1
X203	Option slot 2
X204	Option slot 3
X205	Memory unit connection (memory unit inserted in the picture)
X208	Cooling fan 1 connection
X210	Cooling fan 2 connection
J1, J2	Voltage/Current selection jumpers (J1, J2) for analog inputs
J3	Drive-to-drive link termination switch (J3)
J6	Common digital input ground selection switch (J6)

Default I/O diagram of the drive control unit (ZCU-1x)

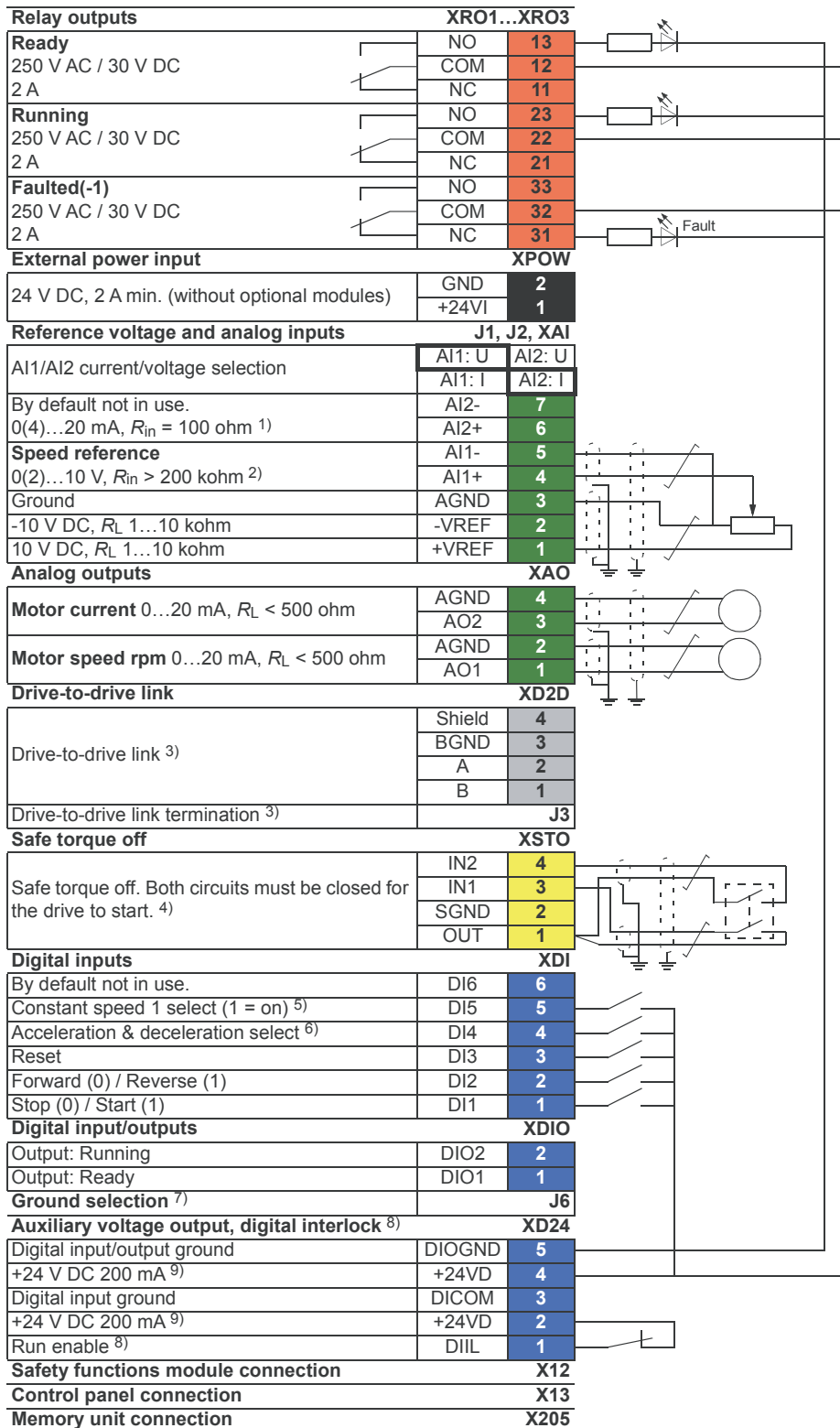

Notes:

The wire size accepted by all screw terminals (for both stranded and solid wire) is 0.5 ... 2.5 mm² (24...12 AWG). The torque is 0.5 N·m (5 lbf·in).

138 Control units of the drive

- 1) Current [0(4)...20 mA, $R_{in} = 100 \text{ ohm}$] or voltage [0(2)...10 V, $R_{in} > 200 \text{ kohm}$] input selected by switch AI2. Change of setting requires reboot of control unit.
 - 2) Current [0(4)...20 mA, $R_{in} = 100 \text{ ohm}$] or voltage [0(2)...10 V, $R_{in} > 200 \text{ kohm}$] input selected by switch AI1. Change of setting requires reboot of control unit.
 - 3) See section [The XD2D connector \(page 140\)](#).
 - 4) See chapter [The Safe torque off function \(page 257\)](#).
 - 5) Constant speed 1 is defined by parameter 22.26.
 - 6) 0 = Acceleration/deceleration ramps defined by parameters 23.12/23.13 in use. 1 = Acceleration/deceleration ramps defined by parameters 23.14/23.15 in use.
 - 7) Determines whether DICOM is separated from DIOGND (ie. common reference for digital inputs floats; in practice, selects whether the digital inputs are used in current sinking or sourcing mode). See also [ZCU-1x ground isolation diagram \(page 144\)](#). DICOM=DIOGND ON: DICOM connected to DIOGND. OFF: DICOM and DIOGND separate.
 - 8) See section [DIIL input \(page 140\)](#).
 - 9) Total load capacity of these outputs is 4.8 W (200 mA at 24 V) minus the power taken by DIO1 and DIO2.
-

Additional information on the connections

■ External power supply for the control unit (XPOW)

The control unit is powered from a 24 V DC, 2 A supply through terminal block XPOW.

Using an external supply is recommended if

- the control unit needs to be kept operational during input power breaks, for example, because of continuous fieldbus communication
- immediate restart is needed after a power break (that is, no control unit power-up delay is allowed).

■ DI6 as a PTC sensor input

PTC sensors can be connected to this input for motor temperature measurement as follows. The sensor can alternatively be connected to FEN-xx encoder interface module. At the sensor end of the cable, leave the shields unconnected or ground them indirectly via a high-frequency capacitor with a few nanofarads, for example 3.3 nF / 630 V. The shield can also be grounded directly at both ends if they are in the same ground line with no significant voltage drop between the end points. See the firmware manual of the inverter unit for parameter settings.

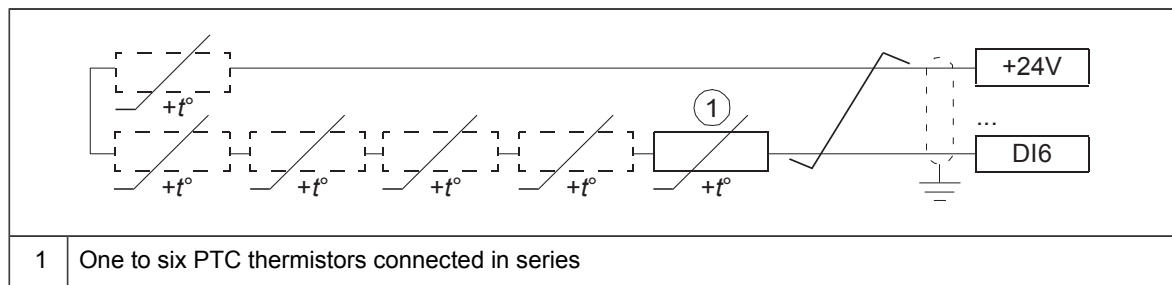

WARNING!

As the inputs pictured above are not insulated according to IEC 60664, the connection of the motor temperature sensor requires double or reinforced insulation between motor live parts and the sensor. If the assembly does not fulfill the requirement, the I/O board terminals must be protected against contact and must not be connected to other equipment or the temperature sensor must be isolated from the I/O terminals.

■ AI1 or AI2 as a Pt100, Pt1000, PTC or KTY84 sensor input

Sensors for motor temperature measurement can be connected between an analog input and output, an example connection is shown below. (Alternatively, you can connect the KTY to an FIO-11 or FAIO-01 analog I/O extension module or FEN-xx encoder interface module.) At the sensor end of the cable, leave the shields unconnected or ground them indirectly via a high-frequency capacitor with a few nanofarads, for example 3.3 nF / 630 V. The shield can also be grounded directly at both ends if they are in the same ground line with no significant voltage drop between the end points.

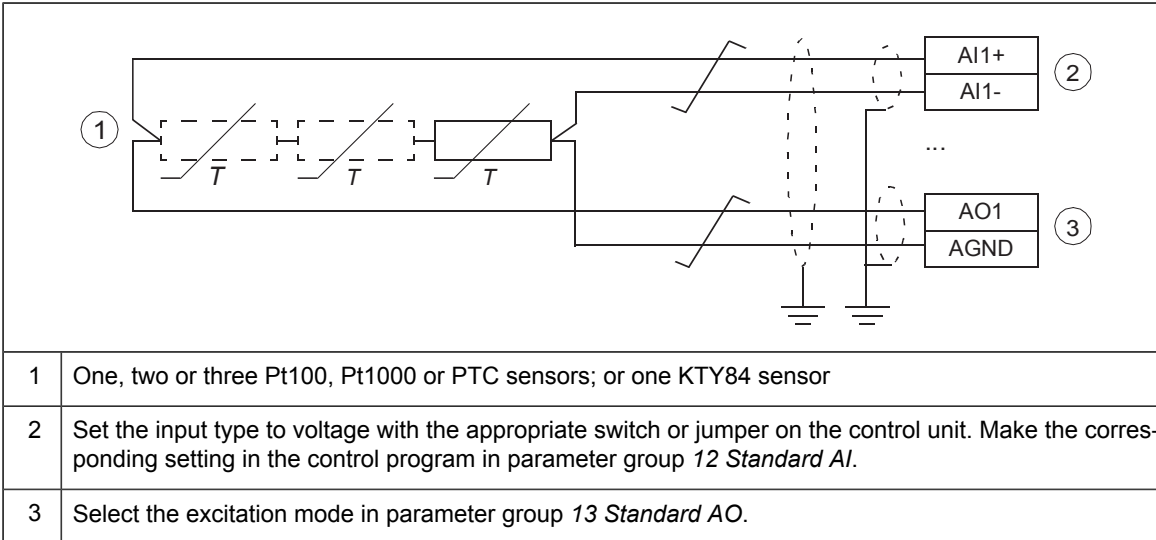

WARNING!

As the inputs pictured above are not insulated according to IEC/EN 60664, the connection of the motor temperature sensor requires double or reinforced insulation between motor live parts and the sensor. If the assembly does not fulfill the requirement, the I/O board terminals must be protected against contact and must not be connected to other equipment, or the temperature sensor must be isolated from the I/O terminals.

■ **DIIL input**

The DIIL input is used for the connection of safety circuits. The input is parametrized to stop the unit when the input signal is lost.

Note: This input is NOT SIL or PI certified.

■ **The XD2D connector**

The XD2D connector provides an RS-485 connection that can be used for

- basic master/follower communication with one master drive and multiple followers,
- fieldbus control through the embedded fieldbus interface (EFB), or
- drive-to-drive (D2D) communication implemented by application programming.

See the firmware manual of the drive for the related parameter settings.

Enable bus termination on the units at the ends of the drive-to-drive link. Disable bus termination on the intermediate units.

Use shielded twisted-pair cable with a twisted pair for data and a wire or another pair for signal ground (nominal impedance 100 to 165 ohm, for example Belden 9842) for the wiring. For best immunity, ABB recommends high quality cable. Keep the cable as short as possible. Avoid unnecessary loops and parallel runs near power cables such as motor cables.

The following diagram shows the wiring between control units.

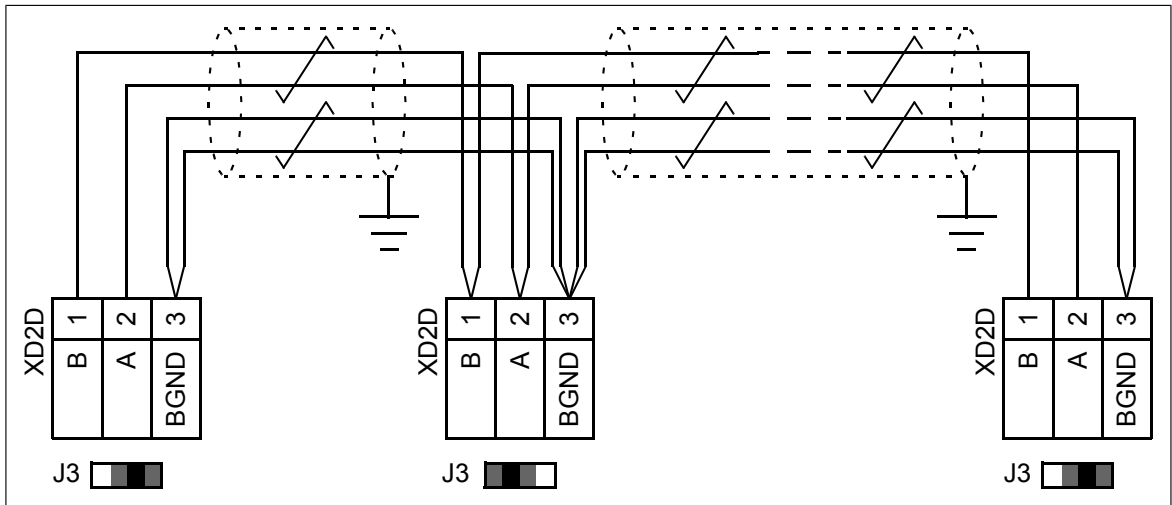
ZCU-12

- **Safe torque off (XSTO)**

See chapter [The Safe torque off function \(page 257\)](#).

Note: The XSTO input only acts as a true Safe torque off input on the inverter control unit. De-energizing the IN1 and/or IN2 terminals of other units (supply, DC/DC converter, or brake unit) will stop the unit but not constitute a true safety function.

- **FSO-xx safety functions module connection (X12)**

See the user manual of the FSO-xx module. Note that the FSO-xx safety functions module is not in use in supply, DC/DC converter or brake units.

Connector data

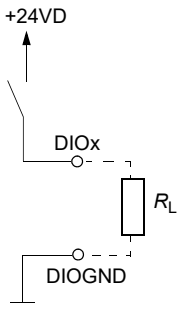
Power supply (XPOW)	Connector pitch 5 mm, wire size 2.5 mm ² 24 V (±10%) DC, 2 A External power input.
Relay outputs RO1...RO3 (XRO1...XRO3)	Connector pitch 5 mm, wire size 2.5 mm ² 250 V AC / 30 V DC, 2 A Protected by varistors
+24 V output (XD24:2 and XD24:4)	Connector pitch 5 mm, wire size 2.5 mm ² Total load capacity of these outputs is 4.8 W (200 mA / 24 V) minus the power taken by DIO1 and DIO2.
Digital inputs DI1...DI6 (XDI:1...XDI:6)	Connector pitch 5 mm, wire size 2.5 mm ² 24 V logic levels: "0" < 5 V, "1" > 15 V R_{in} : 2.0 kohm Input type: NPN/PNP (DI1...DI5), NPN (DI6) Hardware filtering: 0.04 ms, digital filtering up to 8 ms DI6 (XDI:6) can alternatively be used as an input for a PTC sensor. "0" > 4 kohm, "1" < 1.5 kohm. I_{max} : 15 mA (DI1...DI5), 5 mA (DI6)
Start interlock input DIIL (XD24:1)	Connector pitch 5 mm, wire size 2.5 mm ² 24 V logic levels: "0" < 5 V, "1" > 15 V R_{in} : 2.0 kohm Input type: NPN/PNP Hardware filtering: 0.04 ms, digital filtering up to 8 ms
Digital inputs/outputs DIO1 and DIO2 (XDIO:1 and XDIO:2) Input/output mode selection by parameters. DIO1 can be configured as a frequency input (0...16 kHz with hardware filtering of 4 microseconds) for 24 V level square wave signal (sinusoidal or other wave form cannot be used). DIO2 can be configured as a 24 V level square wave frequency output. See the firmware manual, parameter group 111/11.	Connector pitch 5 mm, wire size 2.5 mm ² <u>As inputs</u> : 24 V logic levels: "0" < 5 V, "1" > 15 V. R_{in} : 2.0 kohm. Filtering: 1 ms. <u>As outputs</u> : Total output current from +24VD is limited to 200 mA 
Reference voltage for analog inputs +VREF and -VREF (XAI:1 and XAI:2)	Connector pitch 5 mm, wire size 2.5 mm ² 10 V ±1% and -10 V ±1%, R_{load} 1...10 kohm Maximum output current: 10 mA
Analog inputs AI1 and AI2 (XAI:4 ... XAI:7). Current/voltage input mode selection by jumpers	Connector pitch 5 mm, wire size 2.5 mm ² Current input: -20...20 mA, R_{in} = 100 ohm Voltage input: -10...10 V, R_{in} > 200 kohm Differential inputs, common mode range ±30 V Sampling interval per channel: 0.25 ms Hardware filtering: 0.25 ms, adjustable digital filtering up to 8 ms Resolution: 11 bit + sign bit Inaccuracy: 1% of full scale range

Analog outputs AO1 and AO2 (XAO)	<p>Connector pitch 5 mm, wire size 2.5 mm² 0...20 mA, $R_{load} < 500$ ohm Frequency range: 0...300 Hz Resolution: 11 bit + sign bit Inaccuracy: 2% of full scale range</p>
XD2D connector	<p>Connector pitch 5 mm, wire size 2.5 mm² Physical layer: RS-485 Transmission rate: 8 Mbit/s Cable type: Shielded twisted-pair cable with a twisted pair for data and a wire or another pair for signal ground (nominal impedance 100 ... 165 ohm, for example Belden 9842) Maximum length of link: 50 m (164 ft) Termination by jumper</p>
Safe torque off connection (XSTO)	<p>Connector pitch 5 mm, wire size 2.5 mm² Input voltage range: -3...30 V DC Logic levels: "0" < 5 V, "1" > 17 V.</p> <p>Note: For the unit to start, both connections must be "1". This applies to all control units (including drive, inverter, supply, brake, DC/DC converter etc. control units), but true Safe torque off functionality is only achieved through the XSTO connector of the drive/inverter control unit.</p> <p>EMC (immunity) according to IEC 61326-3-1</p>
Control panel connection (X13)	<p>Connector: RJ-45 Cable length < 3 m</p>
<p>The terminals of the control unit fulfill the Protective Extra Low Voltage (PELV) requirements. The PELV requirements of a relay output are not fulfilled if a voltage higher than 48 V is connected to the relay output.</p>	

■ ZCU-1x ground isolation diagram

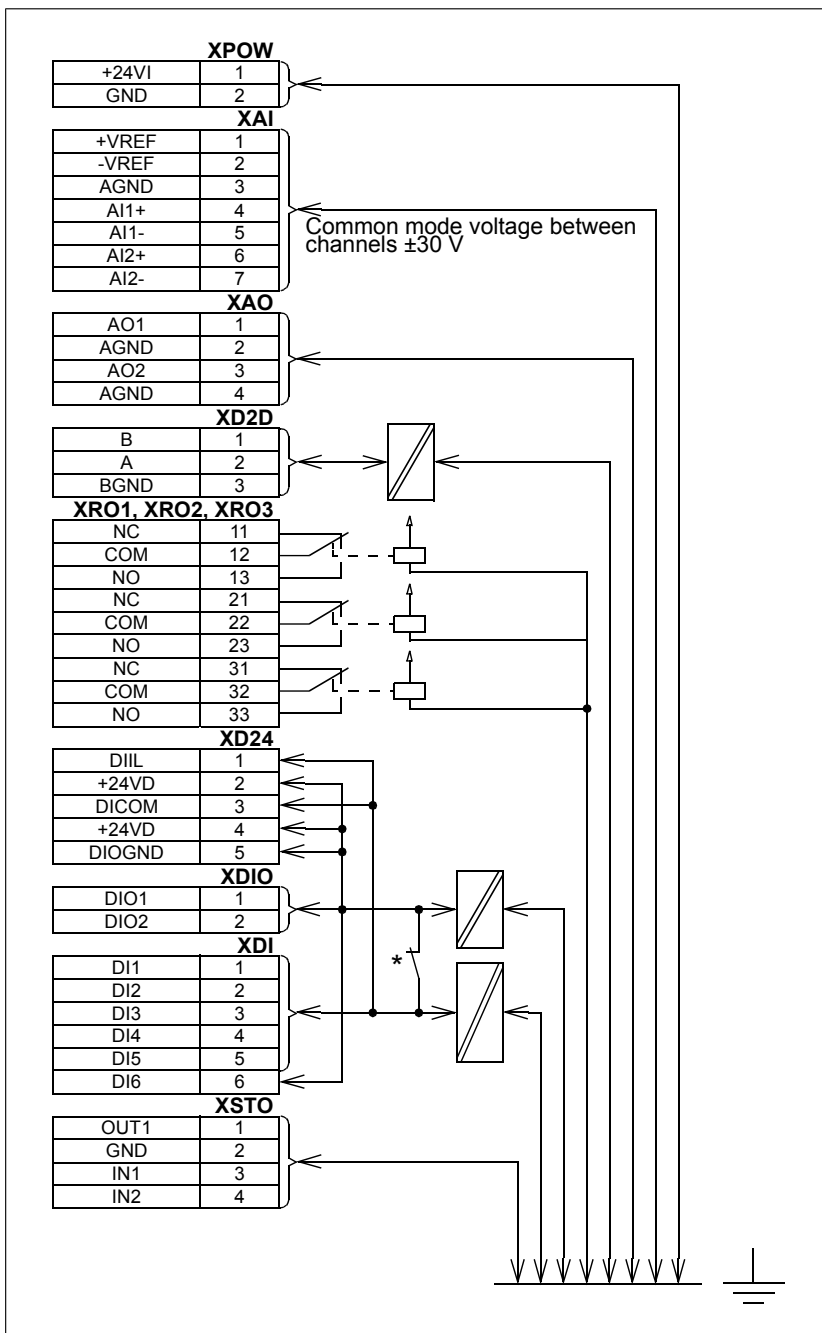

* Ground selector (J6) settings

All digital inputs share a common ground (DICOM connected to DIOGND). This is the default setting.

Ground of digital inputs DI1...DI5 and DIIL (DICOM) is isolated from DIO signal ground (DIOGND). Isolation voltage 50 V.

9

Installation checklist

Contents of this chapter

This chapter contains a checklist of the mechanical and electrical installation of the drive.

Checklist

Examine the mechanical and electrical installation of the drive before start-up. Go through the checklist together with another person.



WARNING!

Obey the safety instructions of the drive. If you ignore them, injury or death, or damage to the equipment can occur.

If you are not a qualified electrical professional, do not do installation or maintenance work.



WARNING!

Stop the drive and do the steps in section [Electrical safety precautions \(page 15\)](#) before you start the work.

Make sure that ...	<input checked="" type="checkbox"/>
The ambient operating conditions meet the drive ambient conditions specification, and enclosure rating (IP code or UL enclosure type).	<input type="checkbox"/>
The supply voltage matches the nominal input voltage of the drive. See the type designation label.	<input type="checkbox"/>
The insulation resistance of the input power cable, motor cable and motor is measured according to local regulations and the manuals of the drive.	<input type="checkbox"/>
The drive is attached securely on an even, vertical and non-flammable wall.	<input type="checkbox"/>
The cooling air flows freely in and out of the drive.	<input type="checkbox"/>

146 Installation checklist

Make sure that ...	<input checked="" type="checkbox"/>
<u>If the drive is connected to a network other than a symmetrically grounded TN-S system:</u> You have done all the required modifications (for example, you may need to disconnect the EMC filter or ground-to-phase varistor). See the electrical installation instructions.	<input type="checkbox"/>
Appropriate AC fuses and main disconnecting device are installed.	<input type="checkbox"/>
There is an adequately sized protective earth (ground) conductor(s) between the drive and the switchboard, the conductor is connected to correct terminal, and the terminal is tightened to the correct torque. Proper grounding has also been measured according to the regulations.	<input type="checkbox"/>
The input power cable is connected to the correct terminals, the phase order is correct, and the terminals are tightened to the correct torque.	<input type="checkbox"/>
There is an adequately sized protective earth (ground) conductor between the motor and the drive, and the conductor is connected to the correct terminal, and the terminal is tightened to the correct torque. Proper grounding has also been measured according to the regulations.	<input type="checkbox"/>
The motor cable is connected to the correct terminals, the phase order is correct, and the terminals are tightened to the correct torque.	<input type="checkbox"/>
The motor cable is routed away from other cables.	<input type="checkbox"/>
No power factor compensation capacitors are connected to the motor cable.	<input type="checkbox"/>
<u>If an external brake resistor is connected to the drive:</u> There is an adequately sized protective earth (ground) conductor between the brake resistor and the drive, and the conductor is connected to the correct terminal, and the terminals are tightened to the correct torque. Proper grounding has also been measured according to the regulations.	<input type="checkbox"/>
<u>If an external brake resistor is connected to the drive:</u> The brake resistor is connected to the correct terminals, and the terminals are tightened to the correct torque.	<input type="checkbox"/>
<u>If an external brake resistor is connected to the drive:</u> The brake resistor cable is routed away from other cables.	<input type="checkbox"/>
The control cables are connected to the correct terminals, and the terminals are tightened to the correct torque.	<input type="checkbox"/>
<u>If a drive bypass connection will be used:</u> The direct-on-line contactor of the motor and the drive output contactor are either mechanically and/or electrically interlocked, that is, they cannot be closed at the same time. A thermal overload device must be used for protection when bypassing the drive. Refer to local codes and regulations.	<input type="checkbox"/>
There are no tools, foreign objects or dust from drilling inside the drive.	<input type="checkbox"/>
The area in front of the drive is clean: the drive cooling fan cannot draw any dust or dirt inside.	<input type="checkbox"/>
Drive covers and cover of the motor connection box are in place.	<input type="checkbox"/>
The motor and the driven equipment are ready for power-up.	<input type="checkbox"/>

10

Start-up

Contents of this chapter

This chapter describes the start-up procedure of the drive.

Start-up procedure

1. Run setup of the drive control program according to the start-up instructions given in quick start-up guide for ACS880 primary control program or in the firmware manual.
 - For drives with resistor braking (option +D150): see also section Start-up in chapter *Resistor braking*.
 - For drives with ABB sine filter, check that parameter **95.15 Special HW settings** is set to *ABB sine filter*. For other sine filters, see *Sine filter hardware manual* ([3AXD50000016814](#) [English]).
 - For drives with ABB motors in explosive atmospheres, see also *ACS880 drives with ABB motors in explosive atmospheres* ([3AXD50000019585](#) [English]).
2. Validate the Safe torque off function according to the instructions given in chapter *The Safe torque off function*.
3. Validate the safety functions (option +Q973 or +Q972) as described in *FSO-12 safety functions module user's manual* ([3AXD50000015612](#) [English]) or in *FSO-21 safety functions module user's manual* ([3AXD50000015614](#) [English]).





11

Fault tracing

Contents of this chapter

This chapter describes the fault tracing possibilities of the drive.

LEDs

Where	LED	Color	When the LED is lit
Control panel mounting platform	POWER	Green	Control unit is powered and +15 V is supplied to the control panel.
	FAULT	Red	Drive in fault state.

■ Warning and fault messages

See the firmware manual for the descriptions, causes and remedies of the drive control program warning and fault messages.

12

Maintenance



WARNING!

Obey the safety instructions of the drive. If you ignore them, injury or death, or damage to the equipment can occur.

Contents of this chapter

This chapter contains preventive maintenance instructions.

Maintenance intervals

The table below shows the maintenance tasks which can be done by the end user. The complete maintenance schedule is available on the Internet (www.abb.com/drivesservices). For more information, consult your local ABB Service representative (www.abb.com/searchchannels).

Maintenance and component replacement intervals are based on the assumption that the equipment is operated within the specified ratings and ambient conditions. ABB recommends annual drive inspections to ensure the highest reliability and optimum performance.

Note: Long term operation near the specified maximum ratings or ambient conditions may require shorter maintenance intervals for certain components. Consult your local ABB Service representative for additional maintenance recommendations.

■ Descriptions of symbols

Action	Description
I	Inspection (visual inspection and maintenance action if needed)
P	Performance of on/off-site work (commissioning, tests, measurements or other work)
R	Replacement

■ **Recommended annual maintenance actions by the user**

ABB recommends these annual inspections to ensure the highest reliability and optimum performance.

Action	Target
P	Quality of supply voltage
I	Spare parts
P	DC circuit capacitor reforming, spare modules and spare capacitors
I	Tightness of terminals
I	Dustiness, corrosion or temperature
I	Heat sink cleaning

■ **Recommended maintenance intervals after start-up**

Component	Years from start-up							
	3	6	9	12	15	18	20	21
Cooling								
Main cooling fan			R			R		
Auxiliary cooling fan for circuit boards (frames R1 to R9)			R			R		
Auxiliary cooling fan IP55 (frames R8 and R9)			R			R		
Aging								
Battery for ZCU control unit		R		R		R		
Battery for control panel			R			R		
4FPS10000239703								

Heatsink

The module heatsink fins pick up dust from the cooling air. The drive runs into overtemperature warnings and faults if the heatsink is not clean. When necessary, clean the heatsink as follows.



WARNING!

Obey the safety instructions of the drive. If you ignore them, injury or death, or damage to the equipment can occur.



WARNING!

Use a vacuum cleaner with antistatic hose and nozzle, and wear a grounding wristband. Using a normal vacuum cleaner creates static discharges which can damage circuit boards.

1. Stop the drive and do the steps in section *Electrical safety precautions (page 15)* before you start the work.
2. Remove the cooling fan(s). See section *Fans* below.

3. Blow clean compressed air (not humid or oily) from bottom to top and simultaneously use a vacuum cleaner at the air outlet to trap the dust. Note: If there is a risk of dust entering adjoining equipment, perform the cleaning in another room.

Note: If there is a risk of dust entering adjoining equipment, perform the cleaning in another room.

4. Reinstall the cooling fan.

Fans

The lifespan of the cooling fans of the drive depend on the running time of the fan, ambient temperature and dust concentration. See the firmware manual for the actual signal which indicates the running time of the cooling fan.

Reset the running time signal after a fan replacement. Also, reset the maintenance counter, if used.

Replacement fans are available from ABB. Do not use other than ABB specified spare parts.

■ **Replacing the main cooling fan of frames R1 to R3**

1. Stop the drive and do the steps in section *Electrical safety precautions (page 15)* before you start the work.
2. Release the retaining clip by pushing with a flat screwdriver and turning to the right.
3. Lift the fan assembly up.
4. Install the new fan assembly in reverse order. Make sure that the fan blows upwards.
5. Reset the counter (if used) in group 5 in the primary control program.



■ Replacing the auxiliary cooling fan of IP55 frames R1 to R3

1. Stop the drive and do the steps in section *Electrical safety precautions (page 15)* before you start the work.
2. Remove the front cover by undoing the mounting screws at the sides.
3. Unplug the fan power supply wires. This fan is installed to X210:FAN2 in control unit.
4. Lift the fan off.
5. Install the new fan in reverse order. Make sure that the arrow (5a) on the fan points upwards. Bundle the wires under the clip (5b)

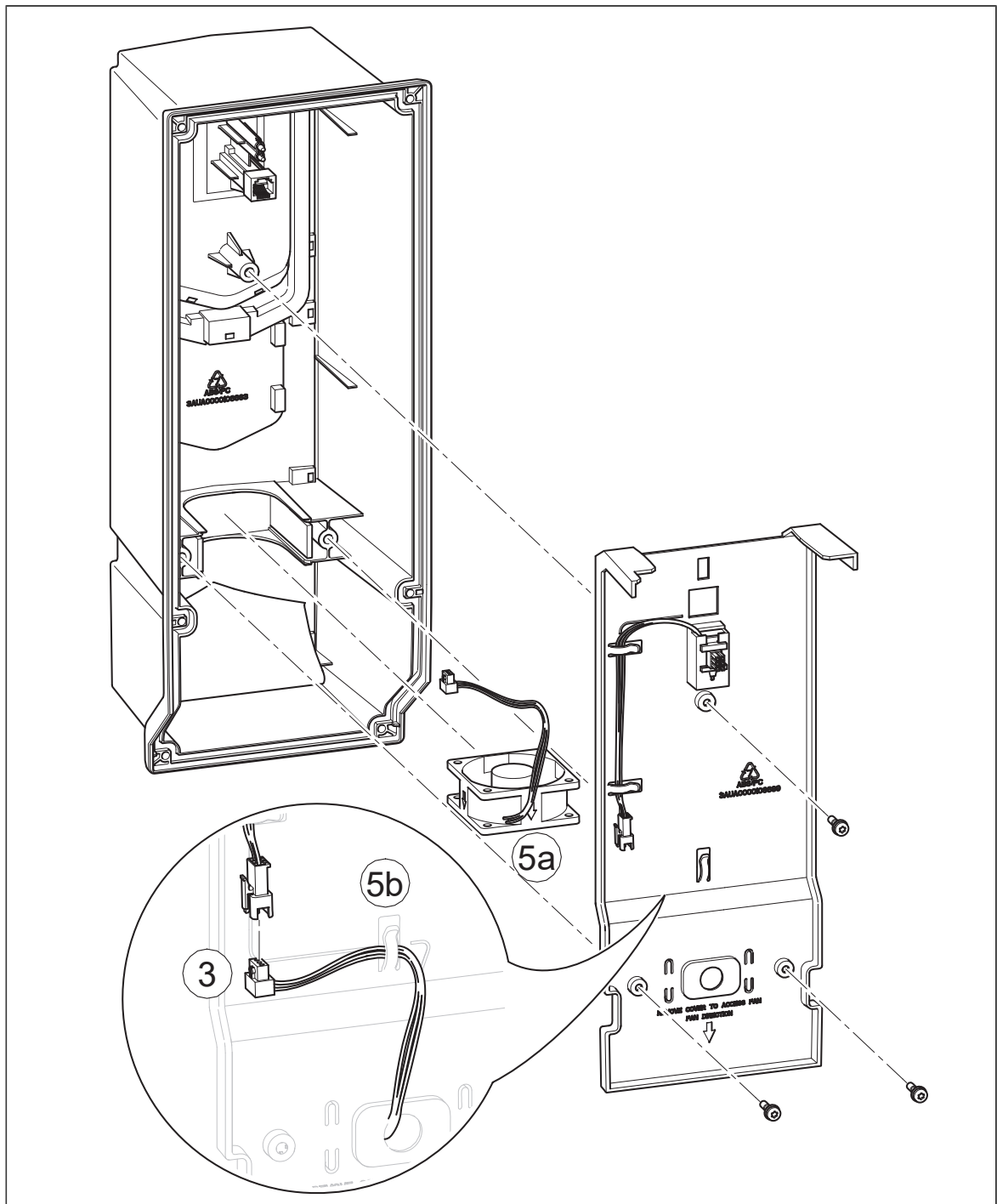

■ Replacing the main cooling fan of frames R4 and R5

1. Stop the drive and do the steps in section [Electrical safety precautions \(page 15\)](#) before you start the work.
2. Lift the fan mounting plate up from the front edge.
3. Unplug the power supply wires.
4. Lift the fan assembly off.
5. Install the new fan assembly in reverse order. Make sure that the fan blows upwards.
6. Reset the counter (if used) in group 5 in the primary control program.



■ Replacing the auxiliary cooling fan of frames R4 and R5

This fan is included in R5 types ACS880-01-xxxx-7 and with option +B056+C135.

1. Stop the drive and do the steps in section *Electrical safety precautions (page 15)* before you start the work.
 2. Remove the front cover.
 3. Unplug the fan power supply wires.
 4. Lift the fan up.
 5. Install the new fan in reverse order. Make sure that the arrow in the fan points to the direction marked on the drive frame.
-

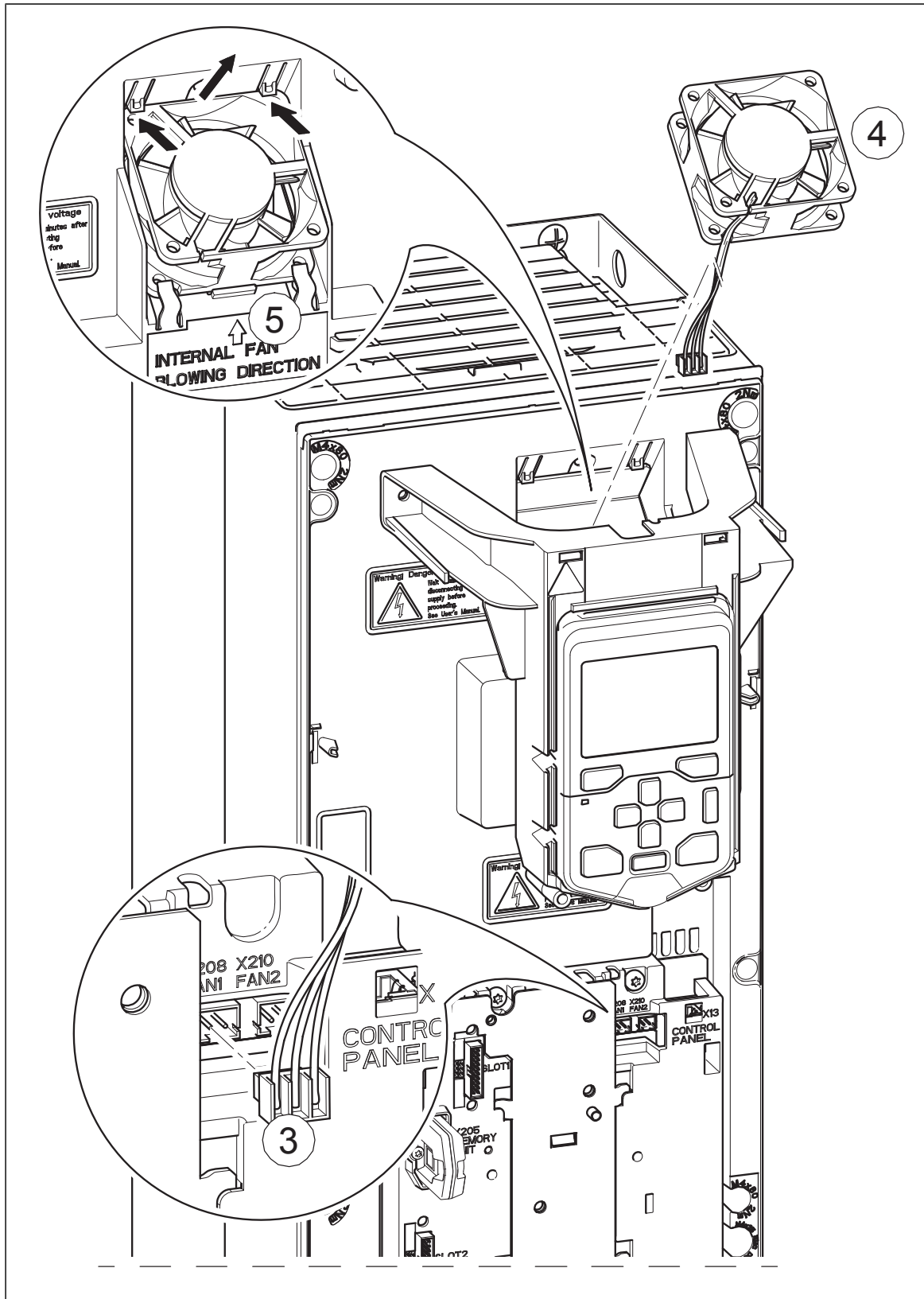

■ Replacing the main cooling fan of frames R6 to R8

1. Stop the drive and do the steps in section *Electrical safety precautions (page 15)* before you start the work.
2. Undo the mounting screws of the fan mounting plate (view from bottom below).
3. Pull the fan mounting plate down from the side edge.
4. Unplug the power supply wires.
5. Lift the fan mounting plate off.
6. Remove the fan from the mounting plate.
7. Install the new fan in reverse order. Make sure that the fan blows upwards.
8. Reset the counter (if used) in group 5 in the primary control program.

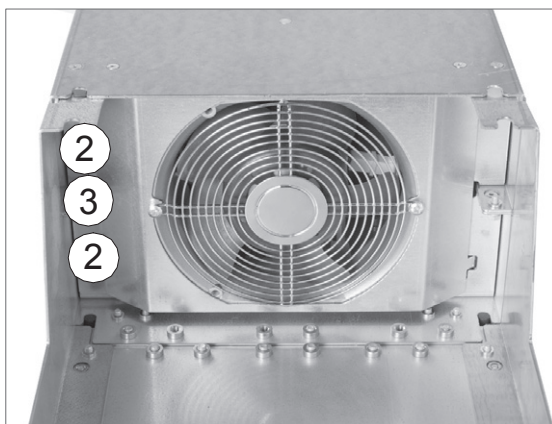

■ **Replacing the auxiliary cooling fan of frames R6 to R9 (IP21, UL Type 1)**

1. Stop the drive and do the steps in section *Electrical safety precautions (page 15)* before you start the work.
2. Remove the lower front cover.
3. Unplug the control panel power supply wires from the control unit terminal X13 and the auxiliary cooling fan power supply wires from the terminal X208:FAN1.
4. Remove the upper front cover.
5. Release the retaining clips.
6. Lift the fan up.
7. Install the new fan in reverse order. Make sure that the arrow on the fan points up.

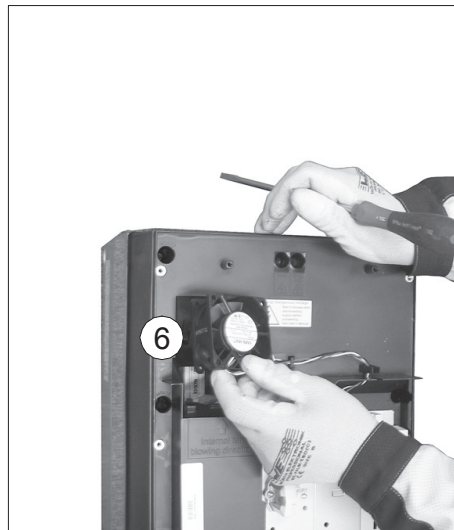
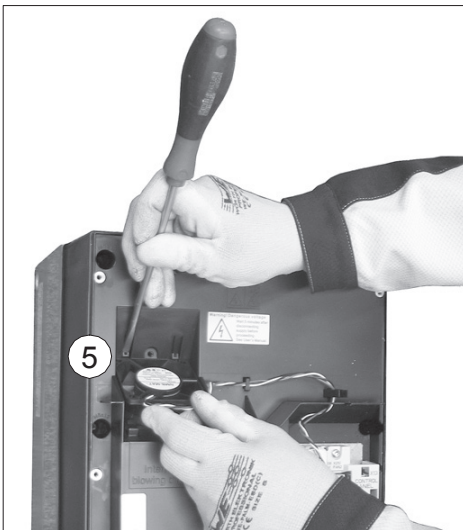
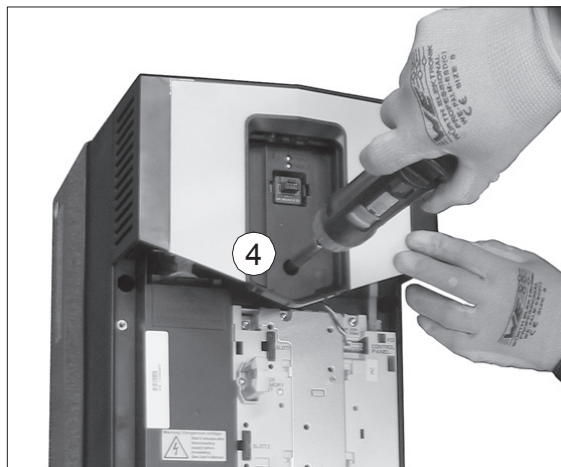
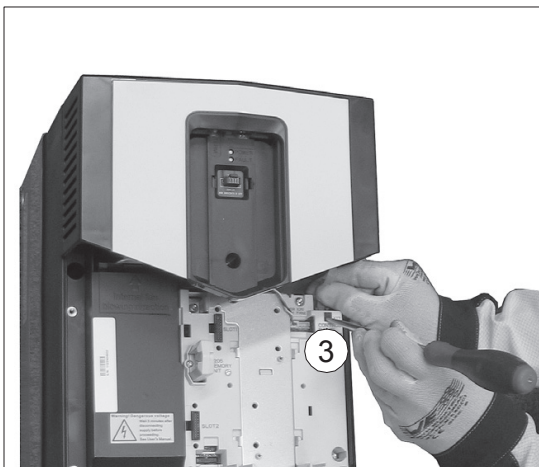

■ **Replacing the auxiliary cooling fan of frames R8 and R9 (IP55, UL Type 12)**

1. Stop the drive and do the steps in section *Electrical safety precautions (page 15)* before you start the work.
 2. Remove the front cover.
 3. Remove the lower front cover from the cover.
 4. Unplug the fan power supply wires. This fan is installed to X210:FAN2 in control unit.
 5. Remove the fan.
 6. Install the new fan in reverse order. Make sure that the arrow on the fan points up.
 7. Reset the counter (if used) in group 5 in the primary control program.
-

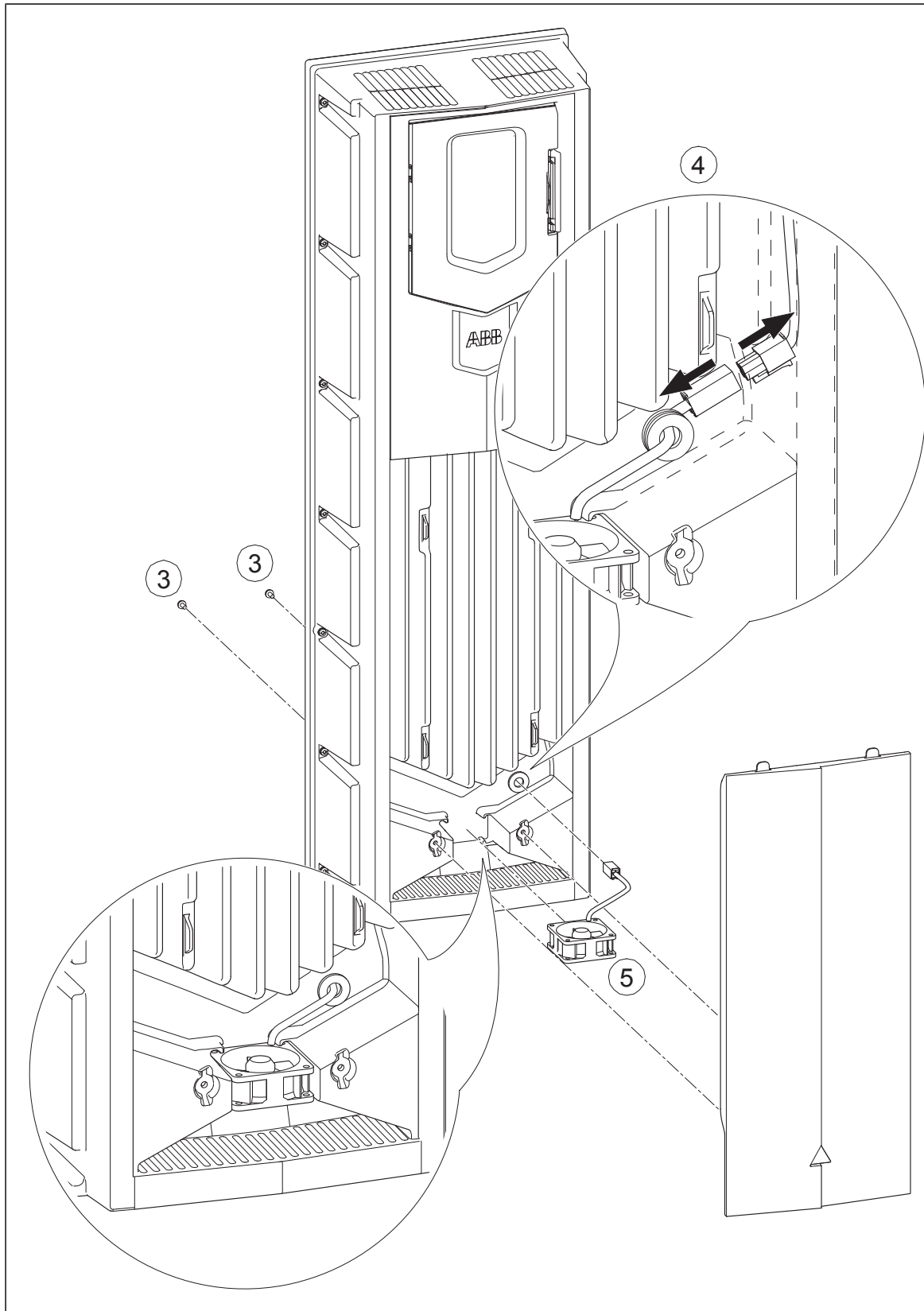

■ Replacing the main cooling fans of frame R9

1. Stop the drive and do the steps in section *Electrical safety precautions (page 15)* before you start the work.
2. Undo the two mounting screws of the fan mounting plate (view from drive bottom below).
3. Turn the mounting plate downwards.
4. Disconnect the fan power supply wires.
5. Remove the fan mounting plate.
6. Remove the fan by undoing the two mounting screws.
7. Install the new fan in reverse order. Make sure that the fan blows upwards.
8. Reset the counter (if used) in group 5 in the primary control program.

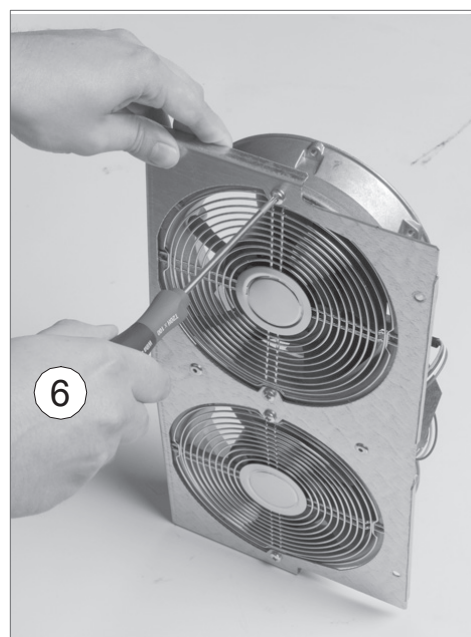
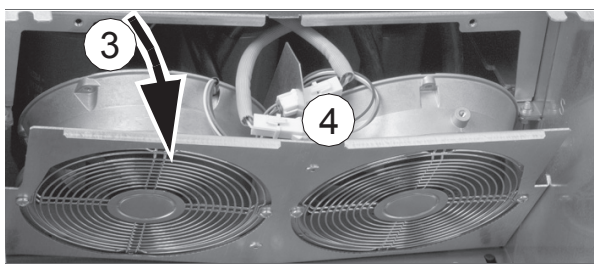
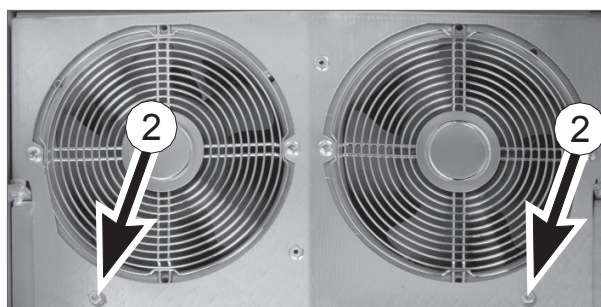

Replacing the drive (IP21, UL Type 1, frames R1 to R9)

This section gives instructions for replacing the drive module without the cable entry box. This allows you to leave the cables installed (except from disconnecting the conductors).

Note: IP55 (UL Type 12) drives: It is not allowed to remove the cable entry box.

1. Stop the drive and do the steps in section *Electrical safety precautions (page 15)* before you start the work.
 2. Remove the front covers.
 3. For frames R6 to R9: Remove the side plates of the cable entry box by loosening the mounting screws.
 4. Disconnect the power and control cables.
 5. Undo the screw(s) that fasten the drive module to the cable entry box.
 6. Undo the two screws or bolts that attach the drive module to the wall from top.
 7. Undo the two screws or bolts which attach the drive module and cable entry box to the wall. Leave the lower wall mounting screws of the cable box in place.
 8. Lift the drive off.
 9. Install the new drive module in reverse order.
-

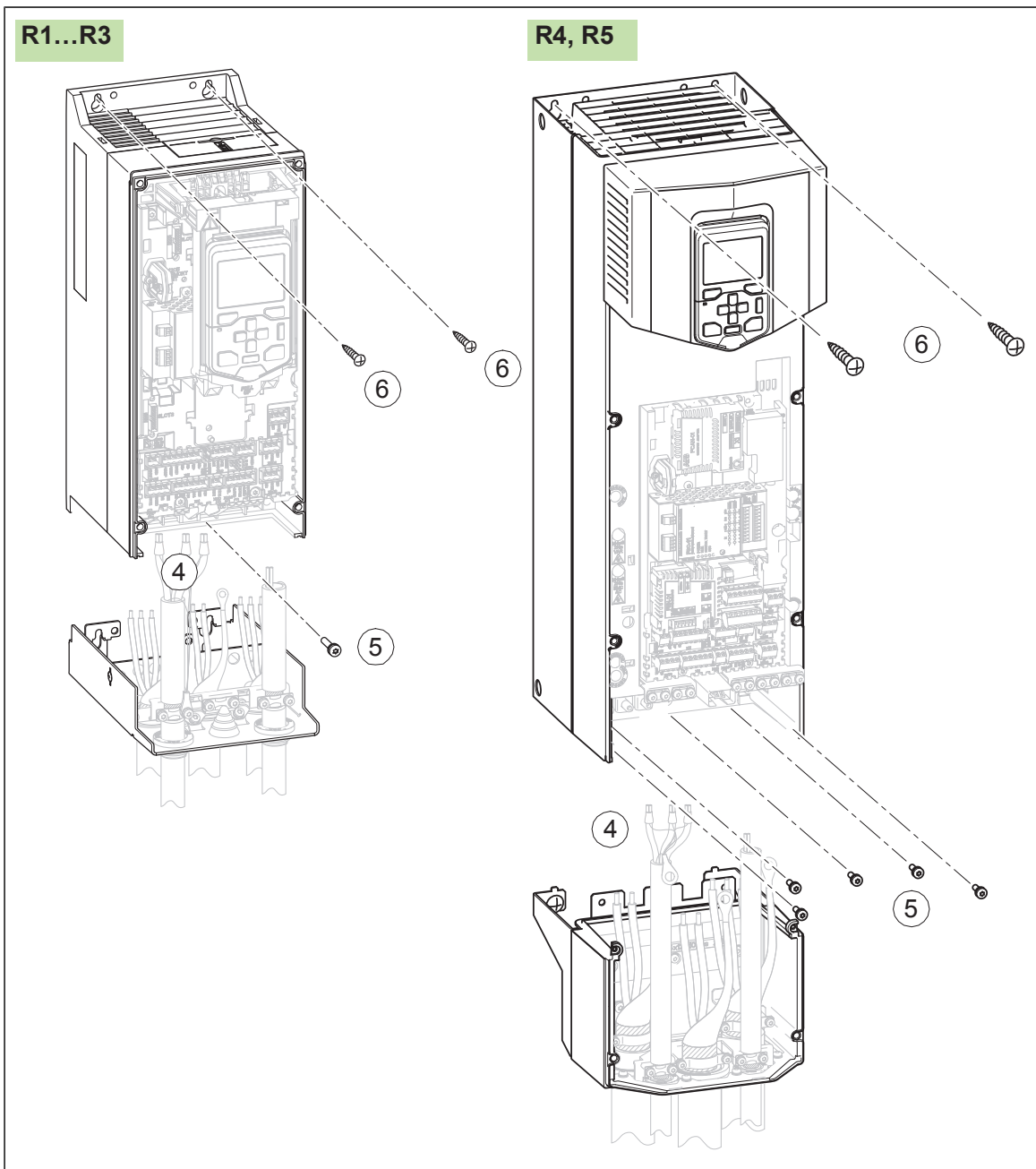

Capacitors

The DC link of the drive contains several electrolytic capacitors. Operating time, load, and surrounding air temperature have an effect on the life of the capacitors. Capacitor life can be extended by decreasing the surrounding air temperature.

Capacitor failure is usually followed by damage to the unit and an input cable fuse failure, or a fault trip. If you think that any capacitors in the drive have failed, contact ABB.

■ Reforming the capacitors

The capacitors must be reformed if the drive has not been powered (either in storage or unused) for a year or more. The manufacturing date is on the type designation label. For information on reforming the capacitors, see *Capacitor reforming instructions* ([3BFE64059629](#) [English]).

Control panel

See *ACx-AP-x assistant control panels user's manual* ([3AUA0000085685](#) [English]).

Control unit

■ Replacing the memory unit of ZCU-12

After replacing a control unit, you can retain the existing parameter settings by transferring the memory unit from the defective control unit to the new control unit. After power-up, the drive will scan the memory unit. This can take several minutes.



WARNING!

Do not remove or insert the memory unit when the control unit is powered.

1. Stop the drive and do the steps in section *Electrical safety precautions (page 15)* before you start the work.
2. Pull the clip at the side of the memory up.

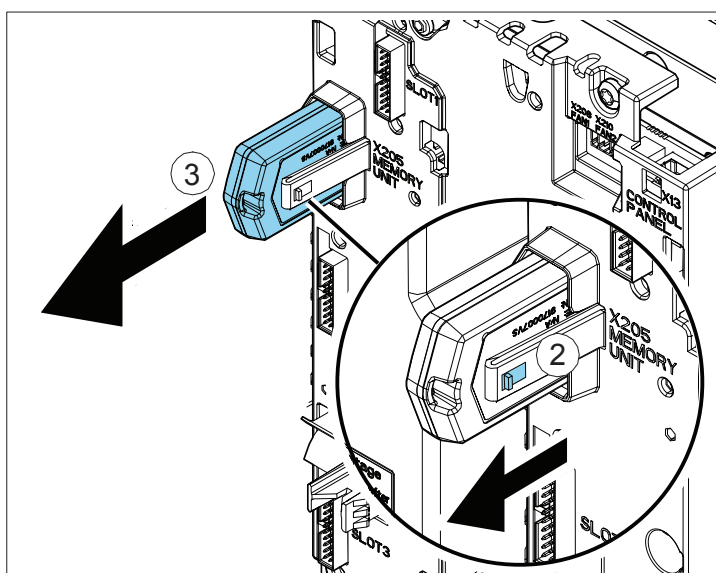

3. Take the unit off.
4. Replace the unit in reverse order.

■ Replacing the ZCU-12 control unit battery

The control unit battery is of type CR2032. For instructions on how to replace the control unit battery, contact an authorized ABB service center.

Replacing safety functions modules (FSO-12, option +Q973 and FSO-21, option +Q972)

Do not repair safety functions modules. Replace a faulty module with a new one as described in section *Installing FSO-xx safety functions modules (page 109)*.



13

Technical data

Contents of this chapter

This chapter contains the technical specifications of the drive, for example, the ratings, sizes and technical requirements, provisions for fulfilling the requirements for CE marking.

Marine type-approved drives (option +C132)

See *ACS880-01/04 +C132 marine type-approved drives supplement* ([3AXD50000010521](#) [English]) for the ratings, marine-specific data and reference to valid marine type approvals.

Drives for SynRM motors

See *ACS880-01 drives for SynRM motors supplement* ([3AXD50000029482](#) [English]) for the ratings, fuses and other technical data.

Ratings

The nominal ratings for the drives with 50 Hz and 60 Hz supply are given below. The symbols are described below the tables. ABB recommends the DriveSize dimensioning tool for selecting the drive, motor and gear combination.

IEC RATINGS										
ACS880-01-...	Frame size	Input rating	Output ratings							
			Nominal use				Light-duty use		Heavy-duty use	
		I_1	I_{max}	I_2	P_n	S_n	I_{Ld}	P_{Ld}	I_{Hd}	P_{Hd}
A	A	A	kW	kVA	A	kW	A	kW		
$U_n = 230\text{ V}$										
04A6-2	R1	4.6	6.3	4.6	0.75	1.8	4.4	0.75	3.7	0.55

IEC RATINGS										
ACS880-01-...	Frame size	Input rating	Output ratings							
			Nominal use				Light-duty use		Heavy-duty use	
		I_1	I_{max}	I_2	P_n	S_n	I_{Ld}	P_{Ld}	I_{Hd}	P_{Hd}
		A	A	A	kW	kVA	A	kW	A	kW
06A6-2	R1	6.6	7.8	6.6	1.1	2.6	6.3	1.1	4.6	0.75
07A5-2	R1	7.5	11.2	7.5	1.5	3.0	7.1	1.5	6.6	1.1
10A6-2	R1	10.6	12.8	10.6	2.2	4.2	10.1	2.2	7.5	1.5
16A8-2	R2	16.8	18.0	16.8	4.0	7	16.0	4.0	10.6	2.2
24A3-2	R2	24.3	28.6	24.3	5.5	10	23.1	5.5	16.8	4.0
031A-2	R3	31.0	41	31	7.5	12	29.3	7.5	24.3	5.5
046A-2	R4	46	64	46	11	18	44	11	38	7.5
061A-2	R4	61	76	61	15	24	58	15	45	11.0
075A-2	R5	75	104	75	18.5	30	71	18.5	61	15
087A-2	R5	87	122	87	22	35	83	22	72	18.5
115A-2	R6	115	148	115	30	46	109	30	87	22.0
145A-2	R6	145	178	145	37	58	138	37	105	30.0
170A-2	R7	170	247	170	45	68	162	45	145	37
206A-2	R7	206	287	206	55	82	196	55	169	45
274A-2	R8	274	362	274	75	109	260	75	213	55
$U_n = 400\text{ V}$										
02A4-3	R1	2.4	3.1	2.4	0.75	1.7	2.3	0.75	1.8	0.55
03A3-3	R1	3.3	4.1	3.3	1.1	2.3	3.1	1.1	2.4	0.75
04A0-3	R1	4.0	5.6	4.0	1.5	2.8	3.8	1.5	3.3	1.1
05A6-3	R1	5.6	6.8	5.6	2.2	3.9	5.3	2.2	4.0	1.5
07A2-3	R1	8.0	9.5	8.0	3.0	5.5	7.6	3.0	5.6	2.2
09A4-3	R1	10.0	12.2	10.0	4.0	6.9	9.5	4.0	8.0	3.0
12A6-3	R1	12.9	16.0	12.9	5.5	8.9	12.0	5.5	10.0	4.0
017A-3	R2	17	21	17	7.5	12	16	7.5	12.6	5.5
025A-3	R2	25	29	25	11	17	24	11	17	7.5
032A-3	R3	32	42	32	15	22	30	15	25	11
038A-3	R3	38	54	38	18.5	26	36	18.5	32	15.0
045A-3	R4	45	64	45	22	31	43	22	38	18.5
061A-3	R4	61	76	61	30	42	58	30	45	22
072A-3	R5	72	104	72	37	50	68	37	61	30
087A-3	R5	87	122	87	45	60	83	45	72	37
105A-3	R6	105	148	105	55	73	100	55	87	45
145A-3	R6	145	178	145	75	100	138	75	105	55
169A-3	R7	169	247	169	90	117	161	90	145	75
206A-3	R7	206	287	206	110	143	196	110	169	90
246A-3	R8	246	350	246	132	170	234	132	206	110
293A-3	R8	293	418	293	160	203	278	160	246*	132

IEC RATINGS										
ACS880-01-...	Frame size	Input rating	Output ratings							
			Nominal use				Light-duty use		Heavy-duty use	
		I_1	I_{max}	I_2	P_n	S_n	I_{Ld}	P_{Ld}	I_{Hd}	P_{Hd}
		A	A	A	kW	kVA	A	kW	A	kW
363A-3	R9	363	498	363	200	251	345	200	293	160
430A-3	R9	430	545	430	250	298	400	200	363**	200
$U_n = 400\text{ V}$										
02A1-5	R1	2.1	3.1	2.1	0.75	1.8	2.0	0.55	1.7	0.55
03A0-5	R1	3.0	4.1	3.0	1.1	2.6	2.8	1.1	2.1	0.75
03A4-5	R1	3.4	5.6	3.4	1.1	2.9	3.2	1.1	3.0	1.1
04A8-5	R1	4.8	6.8	4.8	1.5	4.2	4.6	1.5	3.4	1.1
05A2-5	R1	5.2	9.8	5.2	2.2	4.5	5.0	2.2	4.8	1.5
07A6-5	R1	7.6	12.2	7.6	3.0	6.6	7.2	3.0	5.2	2.2
11A0-5	R1	11.0	16.6	11.0	4.0	9.5	10.4	4.0	7.6	3.0
014A-5	R2	14	21	14	5.5	12	13	5.5	11	4.0
021A-5	R2	21	29	21	7.5	18	19	7.5	14	5.5
027A-5	R3	27	42	27	11.0	23	26	11.0	1	7.5
034A-5	R3	34	54	34	15.0	29	32	15.0	27	11
040A-5	R4	40	64	40	18.5	35	38	18.5	34	15
052A-5	R4	52	76	52	22	45	49	22	40	19
065A-5	R5	65	104	65	30	56	62	30	52	22
077A-5	R5	77	122	77	37	67	73	37	65	30
096A-5	R6	96	148	96	45	83	91	45	77	37
124A-5	R6	124	178	124	55	107	118	55	96	45
156A-5	R7	156	247	156	75	135	148	75	124	55
180A-5	R7	180	287	180	90	156	171	90	156	75
240A-5	R8	240	350	240	110	208	228	110	180	90
260A-5	R8	260	418	260	132	225	247	132	240*	110
361A-5	R9	361	542	361	200	313	343	160	302	160
414A-5	R9	414	542	414	200	359	393	200	361**	200
$U_n = 500\text{ V}$										
02A1-5	R1	2.1	3.1	2.1	0.75	1.8	2.0	0.75	1.7	0.55
03A0-5	R1	3.0	4.1	3.0	1.1	2.6	2.8	1.1	2.1	0.75
03A4-5	R1	3.4	5.6	3.4	1.5	2.9	3.2	1.5	3.0	1.1
04A8-5	R1	4.8	6.8	4.8	2.2	4.2	4.6	2.2	3.4	1.5
05A2-5	R1	5.2	9.5	5.2	3.0	4.5	4.9	3.0	4.8	2.2
07A6-5	R1	7.6	12.2	7.6	4.0	6.6	7.2	4.0	5.2	3.0
11A0-5	R1	11.0	16.0	11.0	5.5	9.5	10.4	5.5	7.6	4.0
014A-5	R2	14	21	14	7.5	12	13	7.5	11	5.5
021A-5	R2	21	29	21	11	18	19	11	14	7.5
027A-5	R3	27	42	27	15	23	26	15	21	11

IEC RATINGS										
ACS880-01-...	Frame size	Input rating	Output ratings							
			Nominal use				Light-duty use		Heavy-duty use	
		I_1	I_{max}	I_2	P_n	S_n	I_{Ld}	P_{Ld}	I_{Hd}	P_{Hd}
		A	A	A	kW	kVA	A	kW	A	kW
034A-5	R3	34	54	34	18.5	29	32	18.5	27	15
040A-5	R4	40	64	40	22	35	38	22	34	19
052A-5	R4	52	76	52	30	45	49	30	40	22
065A-5	R5	65	104	65	37	56	62	37	52	30
077A-5	R5	77	122	77	45	67	73	45	65	37
096A-5	R6	96	148	96	55	83	91	55	77	45
124A-5	R6	124	178	124	75	107	118	75	96	55
156A-5	R7	156	247	156	90	135	148	90	124	75
180A-5	R7	180	287	180	110	156	171	110	156	90
240A-5	R8	240	350	240	132	208	228	132	180	110
260A-5	R8	260	418	260	160	225	247	160	240*	132
361A-5	R9	361	542	361	200	313	343	200	302	200
414A-5	R9	414	542	414	250	359	393	250	361**	200
$U_n = 690\text{ V}$										
07A4-7	R3	7.4	12.2	7.4	5.5	8.8	7.0	5.5	5.6	4
09A9-7	R3	9.9	18	9.9	7.5	11.8	9.4	7.5	7.4	5.5
14A3-7	R3	14.3	22	14.3	11	17	13.6	11	9.9	7.5
019A-7	R3	19	29	19	15	23	18	15	14.3	11
023A-7	R3	23	38	23	18.5	27	22	18.5	19	15
027A-7	R3	27	46	27	22	32	26	22	23	18.5
035A-7	R5	35	64	35	30	42	33	30	26	22
042A-7	R5	42	70	42	37	50	40	37	35	30
049A-7	R5	49	71	49	45	59	47	45	42	37
061A-7	R6	61	104	61	55	73	58	55	49	45
084A-7	R6	84	124	84	75	100	80	75	61	55
098A-7	R7	98	168	98	90	117	93	90	84	75
119A-7	R7	119	198	119	110	142	113	110	98	90
142A-7	R8	142	250	142	132	170	135	132	119	110
174A-7	R8	174	274	174	160	208	165	160	142	132
210A-7	R9	210	384	210	200	251	200	200	174	160

IEC RATINGS										
ACS880-01-...	Frame size	Input rating	Output ratings							
			Nominal use				Light-duty use		Heavy-duty use	
		I_1	I_{max}	I_2	P_n	S_n	I_{Ld}	P_{Ld}	I_{Hd}	P_{Hd}
		A	A	A	kW	kVA	A	kW	A	kW
271A-7	R9	271	411	271	250	324	257	250	210	200

UL (NEC) RATINGS										
ACS880-01-...	Frame size	Input rating	Output ratings							
			Max. current	App. power	Light-duty use			Heavy-duty use		
		I_1	I_{max}	S_n	I_{Ld}	P_{Ld}		I_{Hd}	P_{Hd}	
		A	A	kVA	A	kW	hp	A	kW	hp
$U_n = 230\text{ V}$										
04A6-2	R1	4.4	6.3	1.8	4.4	0.75	1.0	3.7	0.55	0.75
06A6-2	R1	6.3	7.8	2.6	6.3	1.1	1.5	4.6	0.75	1.0
07A5-2	R1	7.1	11.2	3.0	7.1	1.5	2.0	6.6	1.1	1.5
10A6-2	R1	10.1	12.8	4.2	10.1	2.2	3.0	7.5	1.5	2.0
16A8-2	R2	16.0	18.0	7	16.0	4.0	5.0	10.6	2.2	3.0
24A3-2	R2	23.1	28.6	10	23.1	5.5	7.5	16.8	4.0	5.0
031A-2	R3	29.3	41	12	29.3	7.5	10	24.3	5.5	7.5
046A-2	R4	44	64	18	44	11	15	38	7.5	10
061A-2	R4	58	76	24	58	15	20	45	11.0	15
075A-2	R5	71	104	30	71	18.5	25	61	15	20
087A-2	R5	83	122	35	83	22	30	72	18.5	25
115A-2	R6	109	148	46	109	30	40	87	22.0	30
145A-2	R6	138	178	58	138	37	50	105	30.0	40
170A-2	R7	162	247	68	162	45	60	145	37	50
206A-2	R7	196	287	82	196	55	75	169	45	60
274A-2	R8	260	362	109	260	75	100	213	55	75
$U_n = 480\text{ V}$										
02A1-5	R1	2.1	3.1	1.8	2.1	0.75	1.0	1.7	0.55	0.75
03A0-5	R1	3.0	4.1	2.6	3.0	1.1	1.5	2.1	0.75	1.0
03A4-5	R1	3.4	5.6	2.9	3.4	1.5	2.0	3.0	1.1	1.5
04A8-5	R1	4.8	6.8	4.2	4.8	2.2	3.0	3.4	1.5	2.0
05A2-5	R1	5.2	9.5	4.5	5.2	3.0	3.0	4.8	1.5	2.0
07A6-5	R1	7.6	12.2	6.6	7.6	4.0	5.0	5.2	2.2	3.0
11A0-5	R1	11	16.0	9.5	11	5.5	7.5	7.6	4.0	5.0
014A-5	R2	14	21	12	14	7.5	10	11	5.5	7.5
021A-5	R2	21	29	18	21	11	15	14	7.5	10
027A-5	R3	27	42	23	27	15	20	21	11	15
034A-5	R3	34	54	29	34	18.5	25	27	15	20.0
040A-5	R4	40	64	35	40	22	30	34	18.5	25

UL (NEC) RATINGS										
ACS880-01-...	Frame size	Input rating	Output ratings							
			Max. current	App. power	Light-duty use			Heavy-duty use		
		I_1	I_{max}	S_n	I_{Ld}	P_{Ld}		I_{Hd}	P_{Hd}	
		A	A	kVA	A	kW	hp	A	kW	hp
052A-5	R4	52	76	45	52	30	40	40	22	30
065A-5	R5	65	104	56	65	37	50	52	30	40
077A-5	R5	77	122	67	77	45	60	65	37	50
096A-5	R6	96	148	83	96	55	75	77	45	60
124A-5	R6	124	178	107	124	75	100	96	55	75
156A-5	R7	156	247	135	156	90	125	124	75	100
180A-5	R7	180	287	156	180	110	150	156	90	125
240A-5	R8	240	350	208	240	132	200	180	110	150
260A-5	R8	260	418	225	260	132	200	240*	110	150
302A-5	R9	302	498	262	302	200	250	260	132	200
361A-5	R9	361	542	313	361	200	300	302	200	250
414A-5	R9	414	542	359	414*	250	350	361**	200	300
$U_n = 575\text{ V}$										
07A4-7	R3	7.0	12.2	8.8	7.0	4.0	5.0	5.6	3.0	3.0
09A9-7	R3	9.4	18	11.8	9.4	5.5	7.5	7.4	4.0	5.0
14A3-7	R3	13.6	22	17	13.6	7.5	10	9.9	5.5	7.5
019A-7	R3	18	29	23	18	11	15	14.3	7.5	10
023A-7	R3	22	38	27	22	15	20	19	11	15
027A-7	R3	27	46	32	27	18.5	25	23	15	20
035A-7	R5	41	64	42	41	30	40	32	22	30
042A-7	R5	52	70	50	52	37	50	41	30	40
049A-7	R5	52	71	59	52	37	50	41	30	40
061A-7	R6	62	104	73	62	45	60	52	37	50
084A-7	R6	77	124	100	77	55	75	62	45	60
098A-7	R7	99	168	117	99	75	100	77	55	75
119A-7	R7	125	198	142	125	90	125	99	75	100
142A-7	R8	144	250	170	144	110	150	125	90	125
174A-7 (See Note 4 below)	R8	180	274	208	180	132	200	144	110	150
210A-7	R9	242	384	251	242	160	250	192	132	200
271A-7 (See Note 5 below)	R9	271	411	324	271	200	250	242*	160	250

■ Definitions

U_n	Nominal voltage of the drive
I_1	Nominal rms input current
I_2	Nominal output current (available continuously with no over-loading)
P_n	Typical motor power in no-overload use
S_n	Apparent power
I_{Ld}	Continuous rms output current allowing 10% overload for 1 minute every 5 minutes * I_{Ld} is 414 A in 30 °C ambient temperature and 393 A in 40 °C ambient temperature. The drive can deliver 414 A continuously with no overload in 40 °C.
P_{Ld}	Typical motor power in light-overload use
I_{max}	Maximum output current. Available for 10 seconds at start, then as long as allowed by drive temperature.
I_{Hd}	Continuous rms output current allowing 50% overload for 1 minute every 5 minutes. * Continuous rms output current allowing 30% overload for 1 minute every 5 minutes. ** Continuous rms output current allowing 25% overload for 1 minute every 5 minutes.
P_{Hd}	Typical motor power in heavy-duty use

Note 1: The ratings apply at an ambient temperature of 40 °C (104 °F).

Note 2: To achieve the rated motor power given in the table, the rated current of the drive must be greater than or equal to the rated motor current.

Note 3: Typical motor power for 480 V UL (NEC) ratings applies to 460 V motors.

Note 4 – ACS880-01-174A-7 amp rating: The drive can deliver 192 A continuously with no overload.

Note 5 – ACS880-01-271A-7 power rating: The power rating is as per NEC Table 42.1. However, the drive can be used for a typical 4-pole motor rated to 300 hp meeting NEMA MG 1 Table 12-11 minimum efficiency standard (EPA efficiency electrical motors) if motor full load current is not more than 271 A.

Derating

■ Surrounding air temperature derating

IP21 (UL Type 1) drives and IP55 (UL Type 12) frames R1...R7

In the temperature range +40...55 °C (+104...131 °F), the rated output current is derated by 1% for every added 1 °C (1.8 °F).

To calculate the output current, multiply the current in the ratings table by the derating factor (k):

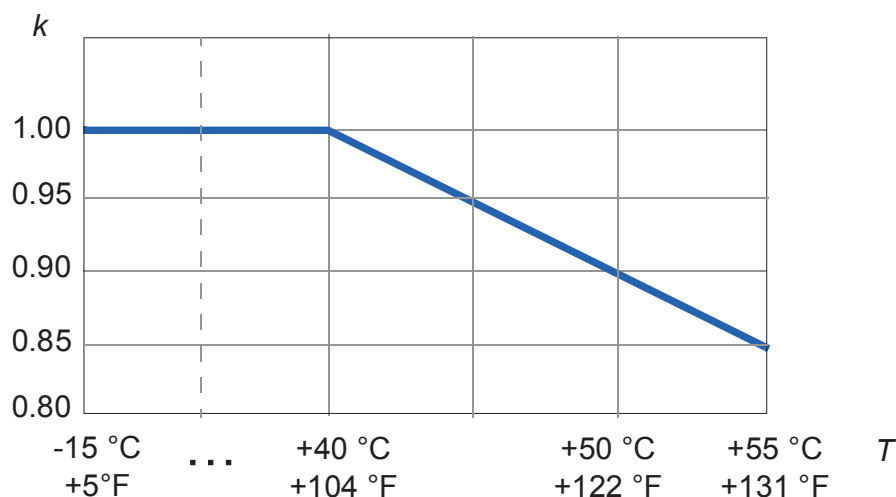

IP55 (UL Type 12) frames R8 and R9

ACS880-01-...	Derated output current (I_2)					
	35 °C (95 °F)	40 °C (104 °F)	45 °C (113 °F)	50 °C (122 °F)	55 °C (131 °F)	Frame
$U_n = 230 \text{ V}$						
274A-2	274	274	260	226	192	R8
$U_n = 400 \text{ V}$						
246A-3	246	246	234	221	209	R8
293A-3	293	293	278	242	209	R8
363A-3	363	363	345	299	209	R9
430A-3	430	363	345	299	209	R9
$U_n = 500 \text{ V}$						
240A-5	240	240	228	216	186	R8
260A-5	260	260	247	216	186	R8
361A-5	361	361	343	298	209	R9
414A-5	414	361	343	298	209	R9
$U_n = 690 \text{ V}$						
142A-7	142	142	135	128	121	R8
174A-7	174	174	165	144	122	R8
210A-7	210	210	186	144	122	R9
271A-7	271	210	186	144	122	R9

ACS880-01-...	Derated output current (I_{Ld})					
	35 °C (95 °F)	40 °C (104 °F)	45 °C (113 °F)	50 °C (122 °F)	55 °C (131 °F)	Frame
$U_n = 230 \text{ V}$						
274A-2	260	260	247	215	182	R8
$U_n = 480 \text{ V}$						
302A-5	302	302	287	249	209	R9

ACS880-01-...	Derated output current (I_{Hd})					
	35 °C (95 °F)	40 °C (104 °F)	45 °C (113 °F)	50 °C (122 °F)	55 °C (131 °F)	Frame
$U_n = 230 \text{ V}$						
274A-2	213	213	202	176	149	R8
$U_n = 480 \text{ V}$						
302A-5	260	260	247	215	182	R9

■ Altitude derating

Altitude derating

At altitudes from 1000 to 4000 m (3300 to 13123 ft) above sea level, the derating is 1% for every 100 m (328 ft). If ambient temperature is below +40 °C (+104 °F), the derating can be reduced by 1.5% for every 1 °C reduction in temperature. For a more accurate derating, use the DriveSize PC tool. A few altitude derating curves are shown below.

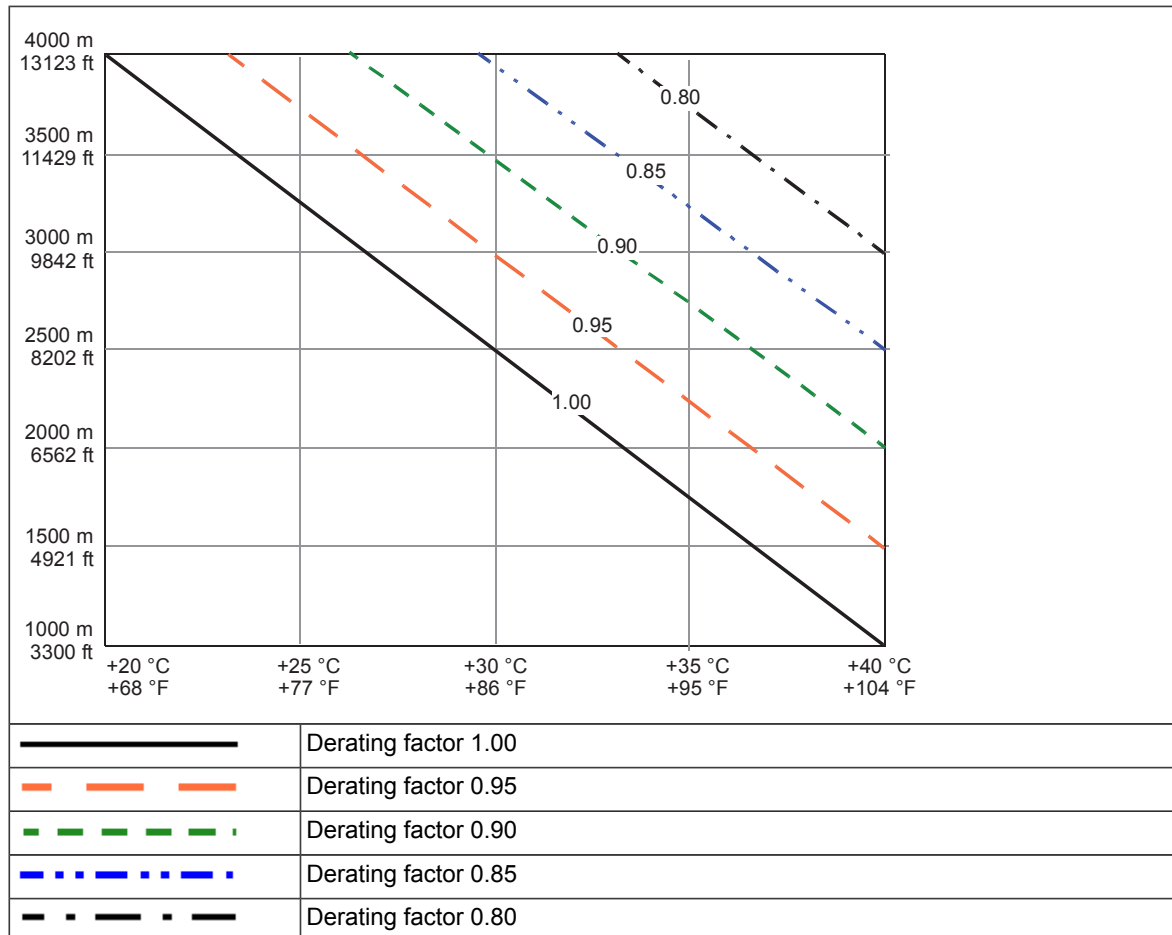

The altitude derating can be reduced if the temperature is below +40 °C, for example, if the temperature is 30 °C, the derating factor is $1 - 1.5\% \cdot 10 = 0.85$. You can reduce the output current by 35% instead of 40% at 4000 meter above the sea level.

■ Deratings for special settings in the drive control program

Enabling special settings in the drive control program can require output current derating.

Ex motor, sine filter, low noise

Deratings are needed in these cases:

- drive is used with an ABB motor for explosive atmospheres (Ex) and *EX motor* in parameter **95.15 Special HW settings** is enabled
- sine filter given in the selection table in chapter *Filters* is used and *ABB Sine filter* in parameter **95.15 Special HW settings** is enabled
- *Low noise optimization* is selected in parameter **97.09 Switching freq mode**.

Note: If Ex motors are used together with sine filters, *EX motor* in parameter **95.15 Special HW settings** is disabled and *ABB Sine filter* in parameter **95.15 Special HW settings** is enabled. Obey the instructions of the motor manufacturer.

ACS880-01-...	Output ratings							
	EX motor (ABB Ex motors)				ABB Sine filter			
	Nominal use		Light-duty use	Heavy-duty use	Nominal use		Light-duty use	Heavy-duty use
	I_N	P_N	I_{Ld}	I_{Hd}	I_N	P_N	I_{Ld}	I_{Hd}
	A	kW	A	A	A	kW	A	A
$U_n = 230\text{ V}$								
04A6-2	4.6	0.75	4.4	3.7	4.3	0.55	4.1	3.5
06A6-2	6.6	1.1	6.3	4.6	6.2	0.8	5.9	4.3
07A5-2	7.5	1.5	7.1	6.6	7.4	1.5	7.0	6.2
10A6-2	10.6	2.2	10.1	7.5	10.0	2.2	9.5	7.4
16A8-2	16.8	4.0	16.0	10.6	15.9	4.0	15.1	10.0
24A3-2	24.3	5.5	23.1	16.8	23.1	5.5	21.9	15.9
031A-2	31	7.5	29.3	24.3	30.5	7.5	29.0	23.1
046A-2	46	11.0	44	38	43.0	11.0	41	31
061A-2	61	15	58	45	58	15	55	41
075A-2	75	19	71	61	65	15	62	55
087A-2	87	22	83	72	77	18.5	73	62
115A-2	106	22	101	87	100	22	95	73
145A-2	134	30	127	105	126	30	120	95
170A-2	161	37	153	134	153	37	145	120
206A-2	195	45	185	161	186	45	177	145
274A-2	251	55	238	195	233	55	221	169
$U_n = 400\text{ V}$								
02A4-3	2.4	0.75	2.3	1.80	2.3	0.75	2.2	1.7
03A3-3	3.3	1.1	3.1	2.4	3.1	1.1	2.9	2.3
04A0-3	4.0	1.5	3.8	3.3	3.8	1.5	3.6	3.1
05A6-3	5.6	2.2	5.3	4.0	5.3	2.2	5.0	3.8
07A2-3	8.0	3.0	7.6	5.6	7.2	3.0	6.8	5.3
09A4-3	10.0	4.0	9.5	8.0	9.2	4.0	8.7	7.2
12A6-3	12.9	5.5	12.0	10.0	12.1	5.5	11.5	9.2
017A-3	17	8	16	12.6	16	7.5	15	12
025A-3	25	11	24	17	24	11	23	16
032A-3	32	15	30	25	31	15	29	23
038A-3	38	19	36	32	37	18.5	35	31
045A-3	45	22	43	38	43	22	41	36
061A-3	61	30	58	45	58	30	55	43
072A-3	72	37	68	61	64	30	61	58
087A-3	87	45	83	72	77	37	73	64
105A-3	97	45	92	87	91	45	86	77

ACS880-01-...	Output ratings							
	EX motor (ABB Ex motors)				ABB Sine filter			
	Nominal use		Light-duty use	Heavy-duty use	Nominal use		Light-duty use	Heavy-duty use
	I_N	P_N	I_{Ld}	I_{Hd}	I_N	P_N	I_{Ld}	I_{Hd}
	A	kW	A	A	A	kW	A	A
145A-3	134	55	127	97	126	55	120	91
169A-3	160	75	152	134	152	75	144	126
206A-3	195	90	185	160	186	90	177	152
246A-3	225	110	214	195	209	110	199	186
293A-3	269	132	256	225*	249	132	237	209*
363A-3	325	160	309	269	296	160	281	249
430A-3	385	200	366	325**	352	160	334	296**
$U_n = 500\text{ V}$								
02A1-5	2.1	0.75	2.0	1.7	1.9	0.55	1.8	1.5
03A0-5	3.0	1.1	2.8	2.1	2.8	0.75	2.7	1.9
03A4-5	3.4	1.5	3.2	3.0	3.1	1.1	2.9	2.8
04A8-5	4.8	2.2	4.6	3.4	4.4	1.5	4.2	3.1
05A2-5	5.2	3.0	5.0	4.8	4.8	2.2	4.6	4.4
07A6-5	7.6	4.0	7.2	5.2	7.0	3.0	6.7	4.8
11A0-5	11.0	5.5	10.4	7.6	10.2	4.0	9.7	7.0
014A-5	14	7.5	13	11	13	5.5	12	10.2
021A-5	21	11.0	19	14	19	7.5	18	13
027A-5	27	15	26	21	25	11.0	24	19.0
034A-5	34	18.5	32	27.0	31	15	29	25
040A-5	40	22	38	34	34	18.5	32	31.0
052A-5	52	30	49	40	44	22	42	34
065A-5	65	37	62	52	52	30	49	44
077A-5	77	45	73	65	61	37	58	52
096A-5	88	45	84	77	82	45	78	61
124A-5	115	55	109	88	104	55	99	82
156A-5	147	75	140	115	140	75	133	104
180A-5	170	90	162	147	161	90	153	140
240A-5	220	110	209	170	204	110	194	161
260A-5	238	132	226	220*	221	110	210	204*
302A-5	270	160	257	238	242	132	230	221
361A-5	322	200	306	270	289	160	275	242
414A-5	370	200	352	322**	332	200	315	289**
$U_n = 690\text{ V}$								
07A4-7	7.4	5.5	7.0	5.6	7.0	4.0	6.7	5.6
09A9-7	9.9	7.5	9.4	7.4	9.4	5.5	8.9	7.0
14A3-7	14.3	11	13.6	9.9	13.6	7.5	12.9	9.4
019A-7	19	15	18	14.3	18	11	17	14

ACS880-01-...	Output ratings							
	EX motor (ABB Ex motors)				ABB Sine filter			
	Nominal use		Light-duty use	Heavy-duty use	Nominal use		Light-duty use	Heavy-duty use
	I_N	P_N	I_{Ld}	I_{Hd}	I_N	P_N	I_{Ld}	I_{Hd}
	A	kW	A	A	A	kW	A	A
023A-7	23	18.5	22	19	22	15	21	18
027A-7	27	22	26	23	26	18.5	25	22
035A-7	35	30	33	26	33	22	31	24
042A-7	42	37	40	35	40	30	38	33
049A-7	49	45	47	42	46	37	44	40
061A-7	61	55	58	49	49	45	47	46
084A-7	84	75	80	61	68	55	65	49
098A-7	98	90	93	84	83	75	79	68
119A-7	119	110	113	98	101	90	96	83
142A-7	126	110	120	119	112	90	106	90
174A-7	154	132	146	126	137	110	130	112
210A-7	184	160	175	154	161	132	153	137
271A-7	238	200	226	184	207	160	197	161

Definitions

U_n Supply voltage range

I_N Nominal output current (available continuously with no over-loading)

P_N Typical motor power in no-overload use

I_{Ld} Continuous rms output current allowing 10% overload for 1 minute every 5 minutes

I_{Hd} Continuous rms output current allowing 50% overload for 1 minute every 5 minutes.

* Continuous rms output current allowing 30% overload for 1 minute every 5 minutes.

** Continuous rms output current allowing 25% overload for 1 minute every 5 minutes.

P_{Hd} Typical motor power in heavy-duty use

Note 1: The ratings apply at an ambient temperature of 40 °C (104 °F).

ACS880-01-...	Output ratings with selection Low noise optimization of parameter 97.09 Switching freq mode		
	Nominal use	Light-duty use	Heavy-duty use
	I_N	I_{Ld}	I_{Hd}
	A	A	A
$U_n = 230 \text{ V}$			
04A6-2	4.1	3.9	3.3
06A6-2	5.9	5.6	4.1
07A5-2	6.7	6.4	5.9
10A6-2	9.5	9.0	6.7
16A8-2	15.0	14.3	9.5
24A3-2	22.0	20.9	15.0

ACS880-01-...	Output ratings with selection Low noise optimization of parameter 97.09 Switching freq mode		
	Nominal use	Light-duty use	Heavy-duty use
	I_N	I_{Ld}	I_{Hd}
	A	A	A
031A-2	30.0	28.5	22.0
046A-2	41.0	39.0	30.0
061A-2	56	53	41
075A-2	56	53	47
087A-2	67	64	56
115A-2	94	89	67
145A-2	118	112	94
170A-2	146	139	118
206A-2	178	169	146
274A-2	216	205	178
$U_n = 400\text{ V}$			
02A4-3	2.2	2.1	1.7
03A3-3	3.0	2.9	2.2
04A0-3	3.6	3.4	3.0
05A6-3	5.0	4.8	3.6
07A2-3	6.5	6.2	5.0
09A4-3	8.5	8.1	6.5
12A6-3	11.3	10.7	8.5
017A-3	15	14.3	11.3
025A-3	22	20.9	15.0
032A-3	30	29	22
038A-3	35	33	30
045A-3	41	39	35
061A-3	56	53	41
072A-3	56	53	47
087A-3	67	64	56
105A-3	86	82	67
145A-3	118	112	86
169A-3	146	139	118
206A-3	178	169	146
246A-3	194	184	178
293A-3	236	224	194*
363A-3	274	260	236
430A-3	325	309	274**
$U_n = 500\text{ V}$			
02A1-5	1.8	1.7	1.4
03A0-5	2.6	2.5	1.8
03A4-5	2.9	2.8	2.6

ACS880-01-...	Output ratings with selection Low noise optimization of parameter 97.09 Switching freq mode		
	Nominal use	Light-duty use	Heavy-duty use
	I_N	I_{Ld}	I_{Hd}
	A	A	A
04A8-5	4.1	3.9	2.9
05A2-5	4.4	4.2	4.1
07A6-5	6.5	6.2	4.4
11A0-5	9.4	8.9	6.5
014A-5	12.0	11.4	9.4
021A-5	18.0	17.1	12.0
027A-5	23.0	21.9	18.0
034A-5	29	28	23
040A-5	29	28	23
052A-5	37	35	29
065A-5	39	37	33
077A-5	46	44	39
096A-5	72	68	46
124A-5	93	88	72
156A-5	133	126	93
180A-5	153	145	133
240A-5	191	181	153
260A-5	206	196	191*
302A-5	206	196	191
361A-5	258	245	206
414A-5	296	281	258**
$U_n = 690\text{ V}$			
07A4-7	7.0	6.7	5.6
09A9-7	9.4	8.9	7.0
14A3-7	13.6	12.9	9.4
019A-7	18	17	14
023A-7	22	21	18
027A-7	26	25	22
035A-7	33	31	24
042A-7	40	38	33
049A-7	46	44	40
061A-7	49	47	46
084A-7	68	65	49
098A-7	83	79	68
119A-7	101	96	83
142A-7	101	96	84
174A-7	122	116	101
210A-7	138	131	122

ACS880-01-...	Output ratings with selection Low noise optimization of parameter 97.09 Switching freq mode		
	Nominal use	Light-duty use	Heavy-duty use
	I_N	I_{Ld}	I_{Hd}
	A	A	A
271A-7	178	169	138

Definitions

U_n Supply voltage range

I_N Nominal output current (available continuously with no over-loading)

P_N Typical motor power in no-overload use

I_{Ld} Continuous rms output current allowing 10% overload for 1 minute every 5 minutes

I_{Hd} Continuous rms output current allowing 50% overload for 1 minute every 5 minutes.

* Continuous rms output current allowing 30% overload for 1 minute every 5 minutes.

** Continuous rms output current allowing 25% overload for 1 minute every 5 minutes.

P_{Hd} Typical motor power in heavy-duty use

Note 1: The ratings apply at an ambient temperature of 40 °C (104 °F).

High speed mode

Selection *High speed mode* of parameter **95.15 Special HW settings** improves control performance at high output frequencies. ABB recommends it to be selected with output frequency of 120 Hz and above.

This table gives the drive ratings for the maximum output frequency when *High speed mode* in parameter **95.15 Special HW settings** is enabled: With output frequencies smaller than this recommended maximum output frequency, the current derating is less than the values given in the table. Contact ABB for operation above the recommended maximum output frequency or for the output current derating with output frequencies above 120 Hz and below the maximum output frequency.

At the output frequency 120 Hz no derating.

ACS880-01-...	Output ratings with selection High speed mode of parameter 95.15 Special HW settings			
	Maximum output frequency			
	f_{max}	Nominal use	Light-duty use	Heavy-duty use
		I_N	I_{Ld}	I_{Hd}
Hz	A	A	A	
$U_n = 230 V$				
04A6-2	500	4.1	3.9	3.3
06A6-2	500	5.9	5.6	4.1
07A5-2	500	6.7	6.4	5.9
10A6-2	500	9.5	9.0	6.7
16A8-2	500	15.0	14.3	9.5
24A3-2	500	22.0	20.9	15.0
031A-2	500	30.0	28.5	22.0
046A-2	500	41.0	39.0	30.0

ACS880-01-...	Output ratings with selection High speed mode of parameter 95.15 Special HW settings			
	Maximum output frequency			
	f_{max}	Nominal use	Light-duty use	Heavy-duty use
		I_N	I_{Ld}	I_{Hd}
Hz	A	A	A	
061A-2	500	56	53	41
075A-2	500	56	53	47
087A-2	500	67	64	56
115A-2	500	84	80	67
145A-2	500	106	101	84
170A-2	500	135	128	106
206A-2	500	165	157	135
274A-2	500	189	180	165
$U_n = 400\text{ V}$				
02A4-3	500	2.2	2.1	1.7
03A3-3	500	3.0	2.9	2.2
04A0-3	500	3.6	3.4	3.0
05A6-3	500	5.0	4.8	3.6
07A2-3	500	6.5	6.2	5.0
09A4-3	500	8.5	8.1	6.5
12A6-3	500	11.3	10.7	8.5
017A-3	500	15	14.3	11.3
025A-3	500	22	20.9	15.0
032A-3	500	30	29	22
038A-3	500	35	33	30
045A-3	500	41	39	35
061A-3	500	56	53	41
072A-3	500	56	53	47
087A-3	500	67	64	56
105A-3	500	77	73	67
145A-3	500	106	101	77
169A-3	500	135	128	106
206A-3	500	165	157	135
246A-3	500	170	162	143
293A-3	500	202	192	170*
363A-3	500	236	224	202
430A-3	500	280	266	236**
$U_n = 500\text{ V}$				
02A1-5	500	1.8	1.7	1.4
03A0-5	500	2.6	2.5	1.8
03A4-5	500	2.9	2.8	2.6
04A8-5	500	4.1	3.9	2.9

ACS880-01-...	Output ratings with selection High speed mode of parameter 95.15 Special HW settings			
	Maximum output frequency			
	f_{max}	Nominal use	Light-duty use	Heavy-duty use
		I_N	I_{Ld}	I_{Hd}
Hz	A	A	A	
05A2-5	500	4.4	4.2	4.1
07A6-5	500	6.5	6.2	4.4
11A0-5	500	9.4	8.9	6.5
014A-5	500	12.0	11.4	9.4
021A-5	500	18.0	17.1	12.0
027A-5	500	23.0	21.9	18.0
034A-5	500	29	28	23
040A-5	500	29	28	23
052A-5	500	37	35	29
065A-5	500	39	37	33
077A-5	500	46	44	39
096A-5	500	58	55	46
124A-5	500	74	70	58
156A-5	500	122	116	74
180A-5	500	140	133	122
240A-5	500	168	160	140
260A-5	500	182	173	168*
302A-5	500	182	173	168
361A-5	500	206	196	182
414A-5	500	236	224	206**
$U_n = 690$ V				
07A4-7	500	6.7	6.4	5.4
09A9-7	500	8.9	8.5	6.7
14A3-7	500	12.9	12.3	8.9
019A-7	500	17	16	13
023A-7	500	21	20	17
027A-7	500	24	23	21
035A-7	500	32	30	23
042A-7	500	38	36	32
049A-7	500	44	42	38
061A-7	500	44	42	40
084A-7	500	53	50	44
098A-7	500	68	65	53
119A-7	500	83	79	68
142A-7	500	83	79	72
174A-7	500	96	91	83
210A-7	500	101	96	83

ACS880-01-...	Output ratings with selection High speed mode of parameter 95.15 Special HW settings			
	Maximum output frequency			
	f_{\max}	Nominal use	Light-duty use	Heavy-duty use
		I_N	I_{Ld}	I_{Hd}
Hz	A	A	A	
271A-7	500	130	124	101

Definitions

f Output frequency

f_{\max} Maximum output frequency with High speed mode

U_n Nominal voltage of the drive

I_N Continuous rms output current. No overload capability at 40 °C (104 °F)

P_N Typical motor power in no-overload use

I_{Ld} Continuous rms output current allowing 10% overload for 1 minute every 5 minutes

I_{Hd} Continuous rms output current allowing 50% overload for 1 minute every 5 minutes.

* Continuous rms output current allowing 30% overload for 1 minute every 5 minutes.

** Continuous rms output current allowing 25% overload for 1 minute every 5 minutes.

Fuses (IEC)

gG and aR fuses for protection against short-circuit in the input power cable or drive are listed below. Either fuse type can be used for frames R1 to R9 if it operates rapidly enough. The operating time depends on the supply network impedance and the cross-sectional area and length of the supply cable.

For frames R7 to R9 ABB recommends ultra-rapid (aR) fuses, see section [Quick guide for selecting between gG and aR fuses \(page 194\)](#).

Note 1: See also section *Implementing short-circuit and thermal overload protection*.

Note 2: Fuses with higher current rating than the recommended ones must not be used. Fuses with lower current rating can be used.

Note 3: For non-UL installations: Fuses from other manufacturers can be used if they meet the ratings and the melting curve of the fuse does not exceed the melting curve of the fuse mentioned in the table.

■ aR fuses DIN 43653 stud-mount (frames R1 to R9)

ABB recommends stud-mount fuses for better cooling but blade style fuses can be used as well.

Ultrarapid (aR) fuses stud-mount (one fuse per phase)							
ACS880-01-...	Min. short-circuit current ¹⁾ (A)	Input current (A)	Fuse				
			A	A ² s	V	Bussmann type	Type DIN 43653
$U_n = 230 \text{ V}$							
04A6-2	40	4.6	16	48	690	170M1309	000
¹⁾ minimum short-circuit current of the installation							

Ultrarapid (aR) fuses stud-mount (one fuse per phase)							
ACS880-01-...	Min. short-circuit current ¹⁾ (A)	Input current (A)	Fuse				
			A	A ² s	V	Bussmann type	Type DIN 43653
06A6-2	40	6.6	16	48	690	170M1309	000
07A5-2	40	7.5	16	48	690	170M1309	000
10A6-2	53	10.6	16	48	690	170M1309	000
16A8-2	65	16.8	25	130	690	170M1311	000
24A3-2	120	24.3	40	460	690	170M1313	000
031A-2	160	31.0	63	1450	690	170M1315	000
046A-2	280	46	80	2550	690	170M1316	000
061A-2	300	61	125	8500	690	170M1318	000
075A-2	380	75	125	7500	690	170M3013	1
087A-2	500	87	160	8500	690	170M3014	1
115A-2	700	115	200	15000	690	170M3015	1
145A-2	1000	145	250	28500	690	170M3016	1
170A-2	1280	170	315	46500	690	170M3017	1
206A-2	1450	206	350	68500	690	170M3018	1
274A-2	2050	274	400	105000	690	170M3019	1
$U_n = 400 \text{ V}$							
02A4-3	65	2.4	25	130	690	170M1311	000
03A3-3	65	3.3	25	130	690	170M1311	000
04A0-3	65	4.0	25	130	690	170M1311	000
05A6-3	65	5.6	25	130	690	170M1311	000
07A2-3	65	8.0	25	130	690	170M1311	000
09A4-3	65	10.0	25	130	690	170M1311	000
12A6-3	65	12.9	25	130	690	170M1311	000
017A-3	120	17	40	460	690	170M1313	000
025A-3	120	25	40	460	690	170M1313	000
032A-3	170	32	63	1450	690	170M1315	000
038A-3	170	38	63	1450	690	170M1315	000
045A-3	280	45	80	2550	690	170M1316	000
061A-3	380	61	100	4650	690	170M1317	000
072A-3	480	72	125	8500	690	170M1318	000

¹⁾ minimum short-circuit current of the installation

Ultrarapid (aR) fuses stud-mount (one fuse per phase)							
ACS880-01-...	Min. short-circuit current ¹⁾ (A)	Input current (A)	Fuse				
			A	A ² s	V	Bussmann type	Type DIN 43653
087A-3	700	87	160	16000	690	170M1319	000
105A-3	1280	105	200	15000	690	170M3015	1
145A-3	1280	145	250	28500	690	170M3016	1
169A-3	1800	169	315	46500	690	170M3017	1
206A-3	2210	206	350	68500	690	170M3018	1
246A-3	3010	246	450	105000	690	170M5009	2
293A-3	4000	293	500	145000	690	170M5010	2
363A-3	5550	363	630	275000	690	170M5012	2
430A-3	7800	430	700	405000	690	170M5013	2
$U_n = 500 \text{ V}$							
02A1-5	65	2.1	25	130	690	170M1308	000
03A0-5	65	3.0	25	130	690	170M1308	000
03A4-5	65	3.4	25	130	690	170M1308	000
04A8-5	65	4.8	25	130	690	170M1308	000
05A2-5	65	5.2	25	130	690	170M1308	000
07A6-5	65	7.6	25	130	690	170M1308	000
11A0-5	65	11.0	25	130	690	170M1308	000
014A-5	120	14	40	460	690	170M1313	000
021A-5	120	21	40	460	690	170M1313	000
027A-5	170	27	63	1450	690	170M1315	000
034A-5	170	34	63	1450	690	170M1315	000
040A-5	280	40	80	2550	690	170M1316	000
052A-5	300	52	100	4650	690	170M1317	000
065A-5	480	65	125	8500	690	170M1318	000
077A-5	700	77	160	16000	690	170M1319	000
096A-5	1000	96	200	15000	690	170M3015	1
124A-5	1280	124	250	28500	690	170M3016	1
156A-5	1610	156	315	46500	690	170M3017	1
180A-5	2210	180	315	46500	690	170M3018	1
240A-5	2620	240	400	74000	690	170M5008	2

¹⁾ minimum short-circuit current of the installation

Ultrarapid (aR) fuses stud-mount (one fuse per phase)							
ACS880-01-...	Min. short-circuit current ¹⁾ (A)	Input current (A)	Fuse				
			A	A ² s	V	Bussmann type	Type DIN 43653
260A-5	4000	260	450	105000	690	170M5009	2
302A-5	5550	302	550	190000	690	170M5011	2
361A-5	5550	361	630	275000	690	170M5012	2
414A-5	7800	414	700	405000	690	170M5013	2
$U_n = 690 \text{ V}$							
07A4-7	40	7.4	16	48	690	170M1309	000
09A9-7	53	9.9	20	78	690	170M1310	000
14A3-7	94	14.3	32	270	690	170M1312	000
019A-7	120	19	40	460	690	170M1313	000
023A-7	160	23	50	770	690	170M1314	000
027A-7	160	27	50	770	690	170M1314	000
035A-7	170	35	63	1450	690	170M1315	000
042A-7	280	42	80	2550	690	170M1316	000
049A-7	280	49	80	2550	690	170M1316	000
061A-7	480	61	125	8500	690	170M1318	000
084A-7	700	84	160	16000	690	170M1319	000
098A-7	1610	98	200	15000	690	170M3015	1
119A-7	1610	119	200	15000	690	170M3015	1
142A-7	2210	142	250	28500	690	170M3016	1
174A-7	2210	174	315	46500	690	170M3017	1
210A-7	3200	210	400	74000	690	170M5008	2
271A-7	3200	271	415	105000	690	170M5009	2
¹⁾ minimum short-circuit current of the installation							

■ **aR fuses DIN 43620 blade style (frames R1 to R9)**

Ultrarapid (aR) fuses blade style (one fuse per phase)							
ACS880-01-...	Min. short-circuit current ¹⁾ (A)	Input current (A)	Fuse				
			A	A ² s	V	Bussmann type	Type DIN 43620
$U_n = 230 \text{ V}$							
¹⁾ minimum short-circuit current of the installation							

Ultrarapid (aR) fuses blade style (one fuse per phase)							
ACS880-01-...	Min. short-circuit current ¹⁾ (A)	Input current (A)	Fuse				
			A	A ² s	V	Bussmann type	Type DIN 43620
04A6-2	40	4.6	16	48	690	170M1559	000
06A6-2	40	6.6	16	48	690	170M1559	000
07A5-2	40	7.5	16	48	690	170M1559	000
10A6-2	53	10.6	20	78	690	170M1560	000
16A8-2	65	16.8	25	130	690	170M1561	000
24A3-2	120	24.3	40	460	690	170M1563	000
031A-2	160	31.0	63	1450	690	170M1565	000
046A-2	280	46	80	2550	690	170M1566	000
061A-2	300	61	125	8500	690	170M1568	000
075A-2	380	75	200	15000	690	170M3815	1
087A-2	500	87	250	28500	690	170M3816	1
115A-2	700	115	315	46500	690	170M3817	1
145A-2	1000	145	315	46500	690	170M3817	1
170A-2	1280	170	450	105000	690	170M5809	2
206A-2	1450	206	500	155000	690	170M5810	2
274A-2	2050	274	630	220000	690	170M5810	3
$U_n = 400 \text{ V}$							
02A4-3	65	2.4	25	130	690	170M1561	000
03A3-3	65	3.3	25	130	690	170M1561	000
04A0-3	65	4.0	25	130	690	170M1561	000
05A6-3	65	5.6	25	130	690	170M1561	000
07A2-3	65	8.0	25	130	690	170M1561	000
09A4-3	65	10.0	25	130	690	170M1561	000
12A6-3	65	12.9	25	130	690	170M1561	000
017A-3	120	17	40	460	690	170M1563	000
025A-3	120	25	40	460	690	170M1563	000
032A-3	170	32	63	1450	690	170M1565	000
038A-3	170	38	63	1450	690	170M1565	000
045A-3	280	45	80	2550	690	170M1566	000
061A-3	380	61	100	4650	690	170M1567	000

¹⁾ minimum short-circuit current of the installation

Ultrarapid (aR) fuses blade style (one fuse per phase)							
ACS880-01-...	Min. short-circuit current ¹⁾ (A)	Input current (A)	Fuse				
			A	A ² s	V	Bussmann type	Type DIN 43620
072A-3	480	72	125	8500	690	170M1568	000
087A-3	700	87	160	16000	690	170M1569	000
105A-3	1280	105	315	46500	690	170M3817	1
145A-3	1280	145	315	46500	690	170M3817	1
169A-3	1800	169	450	105000	690	170M5809	2
206A-3	2210	206	500	145000	690	170M5810	2
246A-3	3010	246	630	275000	690	170M5812	2
293A-3	4000	293	800	490000	690	170M6812D	3
363A-3	5550	363	1000	985000	690	170M6814D	3
430A-3	7800	430	1250	2150000	690	170M8554D	3
$U_n = 500 \text{ V}$							
02A1-5	65	2.1	25	130	690	170M1561	000
03A0-5	65	3.0	25	130	690	170M1561	000
03A4-5	65	3.4	25	130	690	170M1561	000
04A8-5	65	4.8	25	130	690	170M1561	000
05A2-5	65	5.2	25	130	690	170M1561	000
07A6-5	65	7.6	25	130	690	170M1561	000
11A0-5	65	11.0	25	130	690	170M1561	000
014A-5	120	14	40	460	690	170M1563	000
021A-5	120	21	40	460	690	170M1563	000
027A-5	170	27	63	1450	690	170M1565	000
034A-5	170	34	63	1450	690	170M1565	000
040A-5	280	40	80	2550	690	170M1566	000
052A-5	300	52	100	4650	690	170M1567	000
065A-5	480	65	125	8500	690	170M1568	000
077A-5	700	77	160	16000	690	170M1569	000
096A-5	1000	96	250	28500	690	170M3816	1
124A-5	1280	124	315	46500	690	170M3817	1
156A-5	1610	156	400	74000	690	170M5808	2
180A-5	2210	180	500	155000	690	170M5810	2
¹⁾ minimum short-circuit current of the installation							

Ultrarapid (aR) fuses blade style (one fuse per phase)							
ACS880-01-...	Min. short-circuit current ¹⁾ (A)	Input current (A)	Fuse				
			A	A ² s	V	Bussmann type	Type DIN 43620
240A-5	2620	240	550	190000	690	170M5811	2
260A-5	4000	260	800	490000	690	170M6812D	3
302A-5	5550	302	1000	985000	690	170M6814D	3
361A-5	5550	361	1000	985000	690	170M6814D	3
414A-5	7800	414	1250	2150000	690	170M8554D	3
$U_n = 690 \text{ V}$							
07A4-7	40	7.4	16	48	690	170M1559	000
09A9-7	53	9.9	20	78	690	170M1560	000
14A3-7	94	14.3	32	270	690	170M1562	000
019A-7	120	19	40	460	690	170M1563	000
023A-7	160	23	50	770	690	170M1564	000
027A-7	160	27	50	770	690	170M1564	000
035A-7	170	35	63	1450	690	170M1565	000
042A-7	280	42	80	2550	690	170M1566	000
049A-7	280	49	80	2550	690	170M1566	000
061A-7	480	61	125	8500	690	170M1568	000
084A-7	700	84	160	16000	690	170M1569	000
098A-7	1610	98	400	74000	690	170M3816	2
119A-7	1610	119	400	74000	690	170M3816	2
142A-7	2210	142	500	145000	690	170M5810	2
174A-7	2210	174	500	145000	690	170M5810	2
210A-7	3200	210	700	320000	690	170M6811D	3
271A-7	3200	271	700	320000	690	170M6811D	3

¹⁾ minimum short-circuit current of the installation

■ gG fuses DIN 43620 blade style (frames R1 to R9)

Check on the fuse time-current curve to ensure the operating time of the fuse is below 0.5 seconds. Obey the local regulations.

gG fuses (one fuse per phase)							
ACS880-01-...	Min. short-circuit current ¹⁾	Input current	Fuse				
	A	A	A	A ² s	V	ABB type	DIN size
$U_n = 230 \text{ V}$							
04A6-2	40	4.6	6	110	500	OFAF000H6	000
06A6-2	80	6.6	10	360	500	OFAF000H10	000
07A5-2	120	7.5	16	740	500	OFAF000H16	000
10A6-2	120	10.6	16	740	500	OFAF000H16	000
16A8-2	200	16.8	25	2500	500	OFAF000H25	000
24A3-2	350	24.3	40	7700	500	OFAF000H40	000
031A-2	400	31.0	50	16000	500	OFAF000H50	000
046A-2	500	46	63	20100	500	OFAF000H63	000
061A-2	800	61	80	37500	500	OFAF000H80	000
075A-2	1000	75	100	65000	500	OFAF000H100	000
087A-2	1300	87	125	100000	500	OFAF000H125	00
115A-2	1700	115	160	170000	500	OFAF000H160	00
145A-2	2300	145	200	300000	500	OFAF000H200	0
170A-2	3300	170	250	600000	500	OFAF000H250	0
206A-2	5500	206	315	710000	500	OFAF1H315	1
274A-2	7000	274	400	1100000	500	OFAF2H400	2
$U_n = 400 \text{ V}$							
02A4-3	17	2.4	4	53	500	OFAF000H4	000
03A3-3	40	3.3	6	110	500	OFAF000H6	000
04A0-3	40	4.0	6	110	500	OFAF000H6	000
05A6-3	80	5.6	10	355	500	OFAF000H10	000
07A2-3	80	8.0	10	355	500	OFAF000H10	000
09A4-3	120	10.0	16	700	500	OFAF000H16	000
12A6-3	120	12.9	16	700	500	OFAF000H16	000
017A-3	200	17	25	2500	500	OFAF000H25	000
025A-3	250	25	32	4500	500	OFAF000H32	000
¹⁾ minimum short-circuit current of the installation							

gG fuses (one fuse per phase)							
ACS880-01-...	Min. short-circuit current ¹⁾	Input current	Fuse				
	A	A	A	A ² s	V	ABB type	DIN size
032A-3	350	32	40	7700	500	OFAF000H40	000
038A-3	400	38	50	15400	500	OFAF000H50	000
045A-3	500	45	63	21300	500	OFAF000H63	000
061A-3	800	61	80	37000	500	OFAF000H80	000
072A-3	1000	72	100	63600	500	OFAF000H100	000
087A-3	1000	87	100	63600	500	OFAF000H100	000
105A-3	1300	105	125	103000	500	OFAF00H125	00
145A-3	1700	145	160	185000	500	OFAF00H160	00
169A-3	3300	169	250	600000	500	OFAF0H250	0
206A-3	5500	206	315	710000	500	OFAF1H315	1
246A-3	6400	246	355	920000	500	OFAF1H355	1
293A-3	7800	293	425	1300000	500	OFAF2H425	2
363A-3	9400	363	500	2000000	500	OFAF2H500	2
430A-3	10200	430	630	2800000	500	OFAF3H630	3
$U_n = 500 \text{ V}$							
02A1-5	17	2.1	4	53	500	OFAF000H4	000
03A0-5	40	3.0	6	110	500	OFAF000H6	000
03A4-5	40	3.4	6	110	500	OFAF000H6	000
04A8-5	80	4.8	10	355	500	OFAF000H10	000
05A2-5	80	5.2	10	355	500	OFAF000H10	000
07A6-5	120	7.6	16	700	500	OFAF000H16	000
11A0-5	120	11.0	16	700	500	OFAF000H16	000
014A-5	200	14	25	2500	500	OFAF000H25	000
021A-5	250	21	32	4500	500	OFAF000H32	000
027A-5	350	27	40	7700	500	OFAF000H40	000
034A-5	400	34	50	15400	500	OFAF000H50	000
040A-5	500	40	63	21300	500	OFAF000H63	000
052A-5	800	52	80	37000	500	OFAF000H80	000
065A-5	1000	65	100	63600	500	OFAF000H100	000

¹⁾ minimum short-circuit current of the installation

gG fuses (one fuse per phase)							
ACS880-01-...	Min. short-circuit current ¹⁾	Input current	Fuse				
	A	A	A	A ² s	V	ABB type	DIN size
077A-5	1000	77	100	63600	500	OFAF000H100	000
096A-5	1300	96	125	103000	500	OFAF00H125	00
124A-5	1700	124	160	185000	500	OFAF00H160	00
156A-5	3300	156	250	600000	500	OFAF0H250	0
180A-5	5500	180	315	710000	500	OFAF1H315	1
240A-5	6400	240	355	920000	500	OFAF1H355	1
260A-5	7000	260	400	1100000	500	OFAF2H400	2
302A-5	9400	302	500	2000000	500	OFAF2H500	2
361A-5	10200	361	630	2800000	500	OFAF3H630	3
414A-5	10200	414	630	2800000	500	OFAF3H630	3
$U_n = 690 \text{ V}$							
07A4-7	115	7.4	16	1200	690	OFAA000GG16	000
09A9-7	145	9.9	20	2400	690	OFAA000GG20	000
14A3-7	190	14.3	25	4000	690	OFAA000GG25	000
019A-7	280	19	35	12000	690	OFAA000GG35	000
023A-7	450	23	50	24000	690	OFAA000GG50	000
027A-7	450	27	50	24000	690	OFAA000GG50	000
035A-7	520	35	63	30000	690	OFAA000GG63	000
042A-7	800	42	80	51000	690	OFAA0GG80	0
049A-7	800	49	80	51000	690	OFAA0GG80	0
061A-7	1050	61	100	95000	690	OFAA0GG100	0
084A-7	1700	84	160	240000	690	OFAA1GG160	1
098A-7	1700	98	160	240000	690	OFAA1GG160	1
119A-7	2200	119	200	350000	690	OFAA1GG200	1
142A-7	3200	142	250	700000	690	OFAA1GG250	1
174A-7	5500	174	315	850000	690	OFAA2GG315	2
210A-7	7000	210	400	1300000	690	OFAA3GG400	3
271A-7	7000	271	400	1300000	690	OFAA3GG400	3
¹⁾ minimum short-circuit current of the installation							

■ Quick guide for selecting between gG and aR fuses

The combinations (cable size, cable length, transformer size and fuse type) in this table fulfill the minimum requirements for the proper operation of the fuse. Use this table to select between gG and aR fuses or to calculate the short-circuit current of the installation as described in [Calculating the short-circuit current of the installation \(page 196\)](#).

ACS880-01-...	Cable type		Supply transformer minimum apparent power S_N (kVA)					
	Copper	Aluminum	Maximum cable length with gG fuses			Maximum cable length with aR fuses		
	mm ²	mm ²	10 m	50 m	100 m	10 m	100 m	200 m
$U_n = 230 \text{ V}$								
04A6-2	3×1.5	-	1.1	1.1	-	1.1	1.2	-
06A6-2	3×1.5	-	2.2	2.4	-	1.1	1.2	-
07A5-2	3×1.5	-	3.3	4.3	-	1.1	1.2	-
10A6-2	3×1.5	-	3.3	4.3	-	1.5	1.8	-
16A8-2	3×6	-	5.5	5.8	-	1.8	1.8	-
24A3-2	3×6	-	9.7	11	-	3.3	3.5	-
031A-2	3×10	-	11	12	-	4.4	4.6	-
046A-2	3×16	3×35	14	15	-	7.7	8.2	-
061A-2	3×25	3×35	22	24	-	8.3	8.6	-
075A-2	3×35	3×50	28	29	-	11	11	-
087A-2	3×35	3×70	36	39	-	14	15	-
115A-2	3×50	3×70	48	52	-	19	21	-
145A-2	3×95	3×120	64	70	-	28	30	-
170A-2	3×120	3×150	93	104	-	36	39	-
206A-2	3×150	3×240	158	194	-	40	45	-
274A-2	2×(3×95)	2×(3×120)	198	229	-	57	62	-
$U_n = 400 \text{ V}$								
02A4-3	3×1.5	-	0.82	0.82	0.82	3.1	3.4	5.0
03A3-3	3×1.5	-	1.9	1.9	2.0	3.1	3.4	5.0
04A0-3	3×1.5	-	1.9	1.9	2.0	3.1	3.4	5.0
05A6-3	3×1.5	-	3.8	4.0	4.4	3.1	3.4	5.0
07A2-3	3×1.5	-	3.8	4.0	4.4	3.1	3.4	5.0
09A4-3	3×1.5	-	5.8	6.2	8.4	3.1	3.4	5.0
12A6-3	3×1.5	-	5.8	6.2	8.4	3.1	3.4	5.0
017A-3	3×6	-	9.6	9.8	10	5.8	5.9	6.2
025A-3	3×6	-	12	12	13	5.8	5.9	6.2
032A-3	3×10	-	17	17	18	8.2	8.3	8.7
038A-3	3×10	-	19	20	21	8.2	8.3	8.7
045A-3	3×16	3×25	24	24	26	13	14	15
061A-3	3×25	3×25	39	39	42	18	19	20
072A-3	3×35	3×35	48	49	52	23	24	25
087A-3	3×35	3×50	48	49	52	34	35	38
105A-3	3×50	3×70	63	65	68	62	67	80

ACS880-01-...	Cable type		Supply transformer minimum apparent power S_N (kVA)					
	Copper	Aluminum	Maximum cable length with gG fuses			Maximum cable length with aR fuses		
	mm ²	mm ²	10 m	50 m	100 m	10 m	100 m	200 m
145A-3	3×95	3×95	82	85	88	62	65	70
169A-3	3×120	3×150	160	170	187	87	93	104
206A-3	3×150	3×185	269	298	357	107	116	132
246A-3	2×(3×70)	2×(3×95)	311	335	393	145	157	180
293A-3	2×(3×95)	2×(3×120)	380	411	478	193	211	248
363A-3	2×(3×120)	2×(3×185)	459	502	591	269	304	378
430A-3	2×(3×150)	2×(3×240)	499	547	641	380	452	634
$U_n = 500$ V								
02A1-5	3×1.5	-	1.0	1.0	1.0	3.9	4.1	5.0
03A0-5	3×1.5	-	2.4	2.4	2.4	3.9	4.1	5.0
03A4-5	3×1.5	-	2.4	2.4	2.4	3.9	4.1	5.0
04A8-5	3×1.5	-	4.8	4.9	5.2	3.9	4.1	5.0
05A2-5	3×1.5	-	4.8	4.9	5.2	3.9	4.1	5.0
07A6-5	3×1.5	-	7.2	7.5	8.9	3.9	4.1	5.0
11A0-5	3×1.5	-	7.2	7.5	8.9	3.9	4.1	5.0
014A-5	3×6	-	12	12	12	7.2	7.3	7.6
021A-5	3×6	-	15	15	16	7.2	7.3	7.6
027A-5	3×10	-	21	21	22	10	10	11
034A-5	3×10	-	24	24	25	10	10	11
040A-5	3×16	3×35	30	30	31	17	17	18
052A-5	3×25	3×35	48	49	51	18	18	19
065A-5	3×35	3×50	60	61	63	29	29	30
077A-5	3×35	3×70	60	61	63	42	43	46
096A-5	3×50	3×70	78	80	83	60	63	67
124A-5	3×95	3×120	103	105	108	77	80	85
156A-5	3×120	3×150	200	209	224	97	102	109
180A-5	3×150	3×240	335	362	411	133	143	156
240A-5	2×(3×70)	2×(3×95)	388	410	456	158	165	179
260A-5	2×(3×70)	2×(3×95)	425	452	512	242	262	307
302A-5	2×(3×95)	2×(3×120)	572	617	711	336	372	450
361A-5	2×(3×120)	2×(3×185)	621	669	763	336	368	427
414A-5	2×(3×150)	2×(3×240)	621	666	747	473	539	674
$U_n = 690$ V								
07A4-7	3×1.5	-	9.5	9.5	9.5	3.3	3.3	3.3
09A9-7	3×1.5	-	12	12	12	4.4	4.4	4.4
14A3-7	3×2.5	-	16	16	16	7.8	7.8	7.8
019A-7	3×4	-	23	23	23	9.9	10	10
023A-7	3×6	-	37	37	38	13	13	13
027A-7	3×10	-	37	37	38	13	13	13

ACS880-01-...	Cable type		Supply transformer minimum apparent power S_N (kVA)					
	Copper	Aluminum	Maximum cable length with gG fuses			Maximum cable length with aR fuses		
	mm ²	mm ²	10 m	50 m	100 m	10 m	100 m	200 m
035A-7	3×10	3×25	43	43	44	14	14	14
042A-7	3×16	3×25	66	67	68	23	23	24
049A-7	3×16	3×25	66	67	68	23	23	24
061A-7	3×25	3×35	87	88	90	40	40	41
084A-7	3×35	3×50	141	144	149	58	59	61
098A-7	3×50	3×70	141	143	146	134	138	145
119A-7	3×70	3×95	183	187	192	134	138	145
142A-7	3×95	3×120	267	275	286	184	192	205
174A-7	3×120	3×185	452	476	515	184	192	205
210A-7	3×185	2×(3×95)	584	608	654	266	277	295
271A-7	3×240	2×(3×120)	584	605	640	266	275	289

■ Calculating the short-circuit current of the installation

Check that the short-circuit current of the installation is at least the value given in the fuse table.

The short-circuit current of the installation can be calculated as follows:

$$I_{k2-ph} = \frac{U}{2 \cdot \sqrt{R_c^2 + (Z_k + X_c)^2}}$$

where

I_{k2-ph}	Short-circuit current in symmetrical two-phase short-circuit
U	Network line-to-line voltage (V)
R_c	Cable resistance (ohm)
Z_k	$Z_k = z_k \cdot U_N^2 / S_N =$ transformer impedance (ohm)
z_k	Transformer impedance (%)
U_N	Transformer rated voltage (V)
S_N	Nominal apparent power of the transformer (kVA)
X_c	Cable reactance (ohm)

Calculation example

Drive:

- ACS880-01-145A-3
- Supply voltage = 410 V

Transformer:

- rated power $S_n = 600$ kVA
- rated voltage (drive supply voltage) $U_N = 430$ V
- transformer impedance $z_k = 7.2\%$.

Supply cable:

- length = 170 m
- resistance/length = 0.398 ohm/km
- reactance/length = 0.082 ohm/km.

$$Z_k = z_k \cdot \frac{U_N^2}{S_N} = 0.072 \cdot \frac{(430 \text{ V})^2}{600 \text{ kVA}} = 22.19 \text{ mohm}$$

$$R_c = 170 \text{ m} \cdot 0.398 \frac{\text{ohm}}{\text{km}} = 67.66 \text{ mohm}$$

$$X_c = 170 \text{ m} \cdot 0.082 \frac{\text{ohm}}{\text{km}} = 13.94 \text{ mohm}$$

$$I_{k2\text{-ph}} = \frac{410 \text{ V}}{2 \cdot \sqrt{(67.66 \text{ mohm})^2 + (22.19 \text{ mohm} + 13.94 \text{ mohm})^2}} = 2.7 \text{ kA}$$

The calculated short-circuit current 2.7 kA is higher than the minimum short-circuit current of the drive gG fuse type OFAF00H160 (1700 A). -> The 500 V gG fuse (ABB Control OFAF00H160) can be used.

Fuses (UL)

Fuses for branch circuit protection per NEC are listed below. ABB recommends fast acting class T or faster fuses in the USA. Obey local regulations.

ACS880-01-...	Input current	UL (one fuse per phase)			
	A	A	V	Bussmann type	UL class
$U_n = 230 \text{ V}$					
04A6-2	4.4	15	600	JJS-15	T
06A6-2	6.3	15	600	JJS-15	T
07A5-2	7.1	15	600	JJS-15	T
10A6-2	10.1	20	600	JJS-20	T
16A8-2	16.0	25	600	JJS-25	T
24A3-2	23.1	35	600	JJS-35	T
031A-2	29.3	50	600	JJS-50	T
046A-2	44	80	600	JJS-80	T
061A-2	58	80	600	JJS-80	T
075A-2	71	110	600	JJS-110	T
087A-2	83	110	600	JJS-110	T
115A-2	109	150	600	JJS-150	T
145A-2	138	200	600	JJS-200	T

198 Technical data

ACS880-01-...	Input current	UL (one fuse per phase)			
	A	A	V	Bussmann type	UL class
170A-2	162	250	600	JJS-250	T
206A-2	196	300	600	JJS-300	T
274A-2	260	400	600	JJS-400	T
$U_n = 480 \text{ V}$					
02A1-5	2.1	15	600	JJS-15	T
03A0-5	3.0	15	600	JJS-15	T
03A4-5	3.4	15	600	JJS-15	T
04A8-5	4.8	15	600	JJS-15	T
05A2-5	5.2	15	600	JJS-15	T
07A6-5	7.6	15	600	JJS-15	T
11A0-5	11	20	600	JJS-20	T
014A-5	14	25	600	JJS-25	T
021A-5	21	35	600	JJS-35	T
027A-5	27	40	600	JJS-40	T
034A-5	34	50	600	JJS-50	T
040A-5	40	60	600	JJS-60	T
052A-5	52	80	600	JJS-80	T
065A-5	65	90	600	JJS-90	T
077A-5	77	110	600	JJS-110	T
096A-5	96	150	600	JJS-150	T
124A-5	124	200	600	JJS-200	T
156A-5	156	225	600	JJS-225	T
180A-5	180	300	600	JJS-300	T
240A-5	240	350	600	JJS-350	T
260A-5	260	400	600	JJS-400	T
302A-5	302	400	600	JJS-400	T
361A-5	361	500	600	JJS-500	T
414A-5	414	600	600	JJS-600	T
$U_n = 575 \text{ V}$					
07A4-7	7.0	15	600	JJS-15	T
09A9-7	9.4	20	600	JJS-20	T
14A3-7	13.6	30	600	JJS-30	T
019A-7	18	40	600	JJS-40	T
023A-7	22	50	600	JJS-50	T
027A-7	27	50	600	JJS-50	T
035A-7	41	60	600	JJS-60	T
042A-7	52	80	600	JJS-80	T
049A-7	52	80	600	JJS-80	T
061A-7	62	110	600	JJS-110	T
084A-7	77	150	600	JJS-150	T
098A-7	99	150	600	JJS-150	T

ACS880-01-...	Input current	UL (one fuse per phase)			
	A	A	V	Bussmann type	UL class
119A-7	125	200	600	JJS-200	T
142A-7	144	250	600	JJS-250	T
174A-7	180	300	600	JJS-300	T
210A-7	242	400	600	JJS-400	T
271A-7	271	400	600	JJS-400	T

Note:

1. See also section [Implementing short-circuit and thermal overload protection \(page 73\)](#)
2. The UL listed fuses in this hardware manual are the required branch circuit protection per NEC.
3. Fuses are required as part of the installation. Fuses are not included in the base drive configuration and must be provided by others.
4. Recommended drive fuses must be used to maintain drive UL listing. Additional protection can be used. Refer to local codes and regulations.
5. When installing a drive, always follow installation instructions and NEC requirements.
6. In multicable installations, install only one fuse per phase (not one fuse per conductor).
7. Fuses with a higher current rating than the specified must not be used.
8. Fuses with a lower current rating than specified can be used if they are of the same voltage and are UL 248 listed fast acting or high speed fuses.
9. A fuse of a different class can be used at the high fault rating where the I_{Peak} and I^2t of the new fuse are not greater than those of the specified fuse.
10. UL 248 listed, fast acting or high-speed fuses from other manufacturers can be used, if they meet the rating requirements specified in the rules above.
11. Alternative fuses can be used if they meet certain characteristics. For acceptable fuses, see the manual supplement ([3AXD50000645015 \[English\]](#)).

Circuit breakers (IEC)

■ ABB miniature and molded case circuit breakers

The table below lists the circuit breakers that can be used with the drive.

ACS880-01-...	Frame	ABB miniature circuit breaker		ABB moulded case circuit breaker (Tmax)	
		Type	kA ₁₎	Type	kA ₁₎
$U_n = 230\text{ V}$					
04A6-2	R1	S 203 M/P-B/C 10	5	-	-
06A6-2	R1	S 203 M/P-B/C 10	5	-	-
07A5-2	R1	S 203 M/P-B/C 16	5	-	-
10A6-2	R1	S 203 M/P-B/C 16	5	-	-
16A8-2	R2	S 203 M/P-B/C 20	5	-	-
24A3-2	R2	S 203 M/P-B/C 32	5	-	-

¹⁾ Maximum allowed rated conditional short-circuit current (IEC 61800-5-1) of the electrical power network

200 Technical data

ACS880-01-...	Frame	ABB miniature circuit breaker		ABB moulded case circuit breaker (Tmax)	
		Type	kA ¹⁾	Type	kA ¹⁾
031A-2	R3	S 203 M/P-B/C 50	5	-	-
046A-2	R4	S 803 S-B/C 75	10	-	-
061A-2	R4	S 803 S-B/C 80	10	-	-
075A-2	R5	S 803 S-B/C 125	10	XT2 L 160 Ekip LS/I In=160 3p F F	65
087A-2	R5	S 803 S-B/C 125	10	XT2 L 160 Ekip LS/I In=160 3p F F	65
115A-2	R6	-	-	XT2 L 160 Ekip LS/I In=160 3p F F	65
145A-2	R6	-	-	XT4 L 250 Ekip LS/I In=250 3p F F	65
170A-2	R7	-	-	XT4 L 250 Ekip LS/I In=250 3p F F	65
206A-2	R7	-	-	T4 L 320 PR221DS-LS/I In=320 3p F F	65
274A-2	R8	-	-	T4 L 320 PR221DS-LS/I In=320 3p F F	65
U_n = 400 V					
02A4-3	R1	S 203 M/P-B/C 6	5	-	-
03A3-3	R1	S 203 M/P-B/C 6	5	-	-
04A0-3	R1	S 203 M/P-B/C 6	5	-	-
05A6-3	R1	S 203 M/P-B/C 10	5	-	-
07A2-3	R1	S 203 M/P-B/C 13	5	-	-
09A4-3	R1	S 203 M/P-B/C 13	5	-	-
12A6-3	R1	S 203 M/P-B/C 20	5	-	-
017A-3	R2	S 203 M/P-B/C 25	5	-	-
025A-3	R2	S 203 M/P-B/C 32	5	-	-
032A-3	R3	S 203 M/P-B/C 50	5	-	-
038A-3	R3	S 203 M/P-B/C 63	5	-	-
045A-3	R4	S 803 S-B/C 63	10	-	-
061A-3	R4	S 803 S-B/C 75	10	-	-
072A-3	R5	S 803 S-B/C 125	10	XT2 L 160 Ekip LS/I In=160 3p F F	65
087A-3	R5	S 803 S-B/C 125	10	XT2 L 160 Ekip LS/I In=160 3p F F	65
105A-3	R6	-	-	XT4 L 250 Ekip LS/I In=250 3p F F	65
145A-3	R6	-	-	XT4 L 250 Ekip LS/I In=250 3p F F	65
169A-3	R7	-	-	XT4 L 250 Ekip LS/I In=250 3p F F	65
206A-3	R7	-	-	T4 L 320 PR221DS-LS/I In=320 3p F F	65
246A-3	R8	-	-	T5 L 400 PR221DS-LS/I In=400 3p F F	65
293A-3	R8	-	-	T5 L 630 PR221DS-LS/I In=630 3p F F	65
363A-3	R9	-	-	T5 L 630 PR221DS-LS/I In=630 3p F F	65
430A-3	R9	-	-	T5 L 630 PR221DS-LS/I In=630 3p F F	65
U_n = 500 V					
02A1-5	R1	S 803 S-B/C 6	10	-	-
03A0-5	R1	S 803 S-B/C 6	10	-	-
03A4-5	R1	S 803 S-B/C 6	10	-	-

¹⁾ Maximum allowed rated conditional short-circuit current (IEC 61800-5-1) of the electrical power network

ACS880-01-...	Frame	ABB miniature circuit breaker		ABB moulded case circuit breaker (Tmax)	
		Type	kA ¹⁾	Type	kA ¹⁾
04A8-5	R1	S 803 S-B/C 10	10	-	-
05A2-5	R1	S 803 S-B/C 13	10	-	-
07A6-5	R1	S 803 S-B/C 13	10	-	-
11A0-5	R1	S 803 S-B/C 20	10	-	-
014A-5	R2	S 803 S-B/C 25	10	-	-
021A-5	R2	S 803 S-B/C 32	10	-	-
027A-5	R3	S 803 S-B/C 50	10	-	-
034A-5	R3	S 803 S-B/C 63	10	-	-
040A-5	R4	S 803 S-B/C 63	10	-	-
052A-5	R4	S 803 S-B/C 75	10	-	-
065A-5	R5	S 803 S-B/C 125	10	XT2 L 160 Ekip LS/I In=160 3p F F	65
077A-5	R5	S 803 S-B/C 125	10	XT2 L 160 Ekip LS/I In=160 3p F F	65
096A-5	R6	-	-	XT4 L 250 Ekip LS/I In=250 3p F F	65
124A-5	R6	-	-	XT4 L 250 Ekip LS/I In=250 3p F F	65
156A-5	R7	-	-	XT4 L 250 Ekip LS/I In=250 3p F F	65
180A-5	R7	-	-	T4 L 320 PR221DS-LS/I In=320 3p F F	65
240A-5	R8	-	-	T5 L 630 PR221DS-LS/I In=630 3p F F	65
260A-5	R8	-	-	T5 L 630 PR221DS-LS/I In=630 3p F F	65
302A-5	R9	-	-	T5 L 630 PR221DS-LS/I In=630 3p F F	65
361A-5	R9	-	-	T5 L 630 PR221DS-LS/I In=630 3p F F	65
414A-5	R9	-	-	T5 L 630 PR221DS-LS/I In=630 3p F F	65
U_n = 690 V					
07A4-7	R3	S 803 S-B/C 13	10	XT2 L 160 Ekip LS/I In=160 3p F F	18
09A9-7	R3	S 803 S-B/C 20	10	XT2 L 160 Ekip LS/I In=160 3p F F	18
14A3-7	R3	S 803 S-B/C 25	10	XT2 L 160 Ekip LS/I In=160 3p F F	18
019A-7	R3	S 803 S-B/C 32	10	XT2 L 160 Ekip LS/I In=63 3p F F	18
023A-7	R3	S 803 S-B/C 50	10	XT2 L 160 Ekip LS/I In=63 3p F F	18
027A-7	R3	S 803 S-B/C 63	10	XT2 L 160 Ekip LS/I In=63 3p F F	18
035A-7	R5	S 803 S-B/C 63	10	XT2 L 160 Ekip LS/I In=63 3p F F	18
042A-7	R5	S 803 S-B/C 80	10	XT2 L 160 Ekip LS/I In=100 3p F F	18
049A-7	R5	S 803 S-B/C 80	10	XT2 L 160 Ekip LS/I In=100 3p F F	18
061A-7	R6	S 803 S-B/C 125	10	XT2 L 160 Ekip LS/I In=160 3p F F	20
084A-7	R6	S 803 S-B/C 125	10	XT2 L 160 Ekip LS/I In=160 3p F F	20
098A-7	R7	-	-	XT4 L 250 Ekip LS/I In=250 3p F F	20
119A-7	R7	-	-	XT4 L 250 Ekip LS/I In=250 3p F F	20
142A-7	R8	-	-	XT4 L 250 Ekip LS/I In=250 3p F F	20
174A-7	R8	-	-	T4 L 320 PR221DS-LS/I In=320 3p F F	35
210A-7	R9	-	-	T5 L 400 PR221DS-LS/I In=400 3p F F	35
1) Maximum allowed rated conditional short-circuit current (IEC 61800-5-1) of the electrical power network					

ACS880-01-...	Frame	ABB miniature circuit breaker		ABB moulded case circuit breaker (Tmax)	
		Type	kA ¹⁾	Type	kA ¹⁾
271A-7	R9	-	-	T5 L 630 PR221DS-LS/I In=630 3p F F	35

¹⁾ Maximum allowed rated conditional short-circuit current (IEC 61800-5-1) of the electrical power network

Note: Other circuit breakers can be used with drive if they provide the same electrical characteristics. ABB does not assume any liability whatsoever for the correct function and protection with circuit breakers not listed. Furthermore, if the recommendations given by ABB are not obeyed, the drive can experience problems that warranty does not cover.

Circuit breakers (UL)

■ ABB inverse time circuit breakers

These drives have been tested with ABB inverse time circuit breakers listed below at 65 kA. Fuses are not required with these circuit breakers in UL installations.

Notes below the table must be followed when using these breakers.

ACS880-	Frame	CB Nomin- al cur- rent	CB Voltage	Enclos- ure min. volume	Drive volume	ABB circuit breaker	Max. I^2t	Max. I_{peak}
		A	V	in ³	in ³		A ² s	kA
$U_n = 480$ V								
02A1-05	R1	15	480	8100	459	XT2HU3015AFF000XXX	0.512×10^6	23.2
03A0-5	R1	15	480	8100	459	XT2HU3015AFF000XXX	0.512×10^6	23.2
03A4-5	R1	15	480	8100	459	XT2HU3015AFF000XXX	0.512×10^6	23.2
04A8-5	R1	15	480	8100	459	XT2HU3015AFF000XXX	0.512×10^6	23.2
05A2-5	R1	15	480	8100	459	XT2HU3015AFF000XXX	0.512×10^6	23.2
07A6-5	R1	15	480	8100	459	XT2HU3015AFF000XXX	0.512×10^6	23.2
11A0-5	R1	15	480	8100	459	XT2HU3015AFF000XXX	0.512×10^6	23.2
014A-5	R2	30	480	27720	539	XT2HU3030AFF000XXX	0.512×10^6	23.2
021A-5	R2	30	480	27720	539	XT2HU3030AFF000XXX	0.512×10^6	23.2
027A-5	R3	50	480	27720	737	XT2HU3050AFF000XXX	0.512×10^6	23.2
034A-5	R3	50	480	27720	737	XT2HU3050AFF000XXX	0.512×10^6	23.2
040A-5	R4	70	480	30240	1232	XT2HU3070AFF000XXX	0.512×10^6	23.2
052A-5	R4	70	480	30240	1232	XT2HU3070AFF000XXX	0.512×10^6	23.2
065A-5	R5	125	480	30240	1466	XT2HU3125EFF000XXX	0.98×10^6	30
077A-5	R5	125	480	30240	1466	XT2HU3125EFF000XXX	0.98×10^6	30
096A-5	R6	225	480	53703	2365	XT4HU3225EFF000XXX	0.98×10^6	30
124A-5	R6	225	480	53703	2365	XT4HU3225EFF000XXX	0.98×10^6	30
156A-5	R7	250	480	53703	2948	XT4HU3250EFF000XXX	0.98×10^6	30
180A-5	R7	250	480	53703	2948	XT4HU3250EFF000XXX	0.98×10^6	30
240A-5	R8	400	480	53703	3858	XT5HU340AEFF000XXX	4.2×10^6	47.9
260A-5	R8	400	480	53703	3858	XT5HU340AEFF000XXX	4.2×10^6	47.9

Note:

1. Drive must be mounted in an enclosure of the same or greater volume than the enclosure minimum volume listed in the table.
2. For R1 frame 480 V drives, enclosures must have a solid bottom directly below the drive. Fans, filters or louvers cannot be mounted directly below the drive but can be mounted in adjacent areas on the bottom of the enclosure.
3. When multiple drives are installed in the same enclosure, minimum volume of the enclosure is determined by the largest enclosure minimum volume of the drives plus the volume(s) of each additional drive. Example: For 480 V R6 and R3 drive enclosure, select an enclosure with volume $\geq 53703 \text{ in}^3 + 737 \text{ in}^3 = 54440 \text{ in}^3$.
4. UL Open Type, UL Type 1 and UL Type 12 drives can be used inside of the enclosure. Use drive volume for all three types listed in the table when installing multiple drives in the panel.
5. ABB circuit breaker part number listed in table is a base part number. Last eight characters of the breaker "FF000XXX" represent optional accessories which can be added to the breaker. These accessories have no impact on the performance or rating of the breakers.
6. When installing a drive, always follow installation instructions and NEC requirements
7. Alternative circuit breakers can be used if they meet certain characteristics. For acceptable circuit breakers, see the manual supplement ([3AXD50000645015 \[English\]](#)).

Dimensions, weights and free space requirements

Frame	IP21				
	H1	H2	W	D	Weight
	mm	mm	mm	mm	kg
R1	409	370	155	226	7.0
R2	409	370	155	249	8.4
R3	475	420	172	261	10.8
R4	580	490	203	274	18.6
R5	732	596	203	274	22.8
R6	727	569	252	357	42.2
R7	880	621	284	365	53.0
R8	965	700	300	386	68.0
R9	955	700	380	413	95.0

Frame	UL type 1				
	H1	H2	W	D	Weight
	in.	in.	in.	in.	lb
R1	16.11	14.57	6.10	8.89	15
R2	16.11	14.57	6.10	9.80	19
R3	18.71	16.54	6.77	10.28	24
R4	22.85	19.29	7.99	10.79	41
R5	28.80	23.46	7.99	10.77	50
R6	28.60	22.40	9.92	14.10	93

Frame	UL type 1				
	H1	H2	W	D	Weight
	in.	in.	in.	in.	lb
R7	34.66	24.45	11.18	14.35	117
R8	38.01	27.56	11.81	15.21	150
R9	37.59	27.56	14.96	16.27	209

Frame	IP55				
	H1	H2	W	D	Weight
	mm	mm	mm	mm	kg
R1	450	-	162	292	8.1
R2	450	-	162	315	9.5
R3	525	-	180	327	12.0
R4	580	-	203	344	19.1
R5	732	-	203	344	23.4
R6	727	-	252	421	42.9
R7	880	-	284	423	54.0
R8	966	-	300	452	74.0
R9	955	-	380	477	102.0

Frame	UL type 12				
	H1 *	H2	W **	D	Weight
	in.	in.	in.	in.	lb
R1	17.72	-	6.38	11.50	18
R2	17.72	-	6.38	12.40	21
R3	20.70	-	7.09	12.87	26
R4	22.85	-	7.99	13.53	42
R5	28.80	-	7.99	13.53	52
R6	28.60	-	9.92	16.59	95
R7	34.66	-	11.18	16.65	119
R8	38.01	-	11.81	17.78	163
R9	37.59	-	14.96	18.78	225

■ Definitions

H1 Height with cable entry box

H2 Height without cable entry box (option +P940)

H3 Height with hood

W Width with cable entry box

D Depth with cable entry box

* Hood increases height with 155 mm (6.10 in) in frames R4 to R8 and with 230 mm (9.06 in) in frame R9.

** Hood increases width with 23 mm (0.91 in) in frames R4 and R5, 40 mm (1.57 in) in frames R6 and R7 and 50 mm (1.97 in) in frames R8 and R9.

Note 1: For more information on dimensions, see chapter *Dimension drawings*.

Note 2: For dimensions and weights of option +P940 and +P944, see *ACS880...+P940 and +P944 drive modules supplement* ([3AUJA0000145446](#) [English]).

Note 3: For dimensions of option +C135, see *ACS880-01...+C135 drives with flange mounting kit supplement* ([3AXD50000349814](#) [English]). For the additional weight of the flange mounting kit, see the table below.

Frame	Weight of flange mounting kit (option +C135)	
	kg	lb
R1	2.9	6
R2	3.1	7
R3	4.5	10
R4	4.7	10
R5	4.7	10
R6	4.5	10
R7	5	11
R8	6	13
R9	7	15

■ Package dimensions

Frame	Package		
	Length (mm)	Width (mm)	Height (mm)
R1	574	256	281
R1 (IP55)	574	256	364
R2	574	256	304
R2 (IP55)	574	256	386
R3	624	256	316
R3 IP55	624	256	399
R4	691	290	329
R4 (IP55)	691	290	415
R5 IP21	896	293	329
R6	870	325	580
R7	992	400	568
R8	1145	485	655
R9	1145	485	655

Free space requirements

200 mm (7.87 in.) free space is required at top of the drive.

300 mm (11.81 in.) free space (when measured from the drive base without the cable entry box) is required at bottom of the drive.

Losses, cooling data and noise

ACS880-01-...	Frame	Air flow		Heat dissipation	Noise
		m ³ /h	ft ³ /min	W	dB(A)
<i>U_n</i> = 230 V					
04A6-2	R1	44	26	73	46
06A6-2	R1	44	26	94	46
07A5-2	R1	44	26	122	46
10A6-2	R1	44	26	172	46
16A8-2	R2	88	52	232	51
24A3-2	R2	88	52	337	51
031A-2	R3	134	79	457	57
046A-2	R4	134	79	500	62
061A-2	R4	280	165	630	62
075A-2	R5	280	165	680	62
087A-2	R5	280	165	730	62
115A-2	R6	435	256	840	67
145A-2	R6	435	256	940	67
170A-2	R7	450	265	1260	67
206A-2	R7	450	265	1500	67
274A-2	R8	550	324	2100	65
<i>U_n</i> = 400 V					
02A4-3	R1	44	26	30	46
03A3-3	R1	44	26	40	46
04A0-3	R1	44	26	52	46
05A6-3	R1	44	26	73	46
07A2-3	R1	44	26	94	46
09A4-3	R1	44	26	122	46
12A6-3	R1	44	26	172	46
017A-3	R2	88	52	232	51
025A-3	R2	88	52	337	51
032A-3	R3	134	79	457	57
038A-3	R3	134	79	562	57
045A-3	R4	134	79	667	62
061A-3	R4	280	165	907	62
072A-3	R5	280	165	1117	62
087A-3	R5	280	165	1120	62
105A-3	R6	435	256	1295	67

ACS880-01-...	Frame	Air flow		Heat dissipation	Noise
		m ³ /h	ft ³ /min	W	dB(A)
145A-3	R6	435	256	1440	67
169A-3	R7	450	265	1940	67
206A-3	R7	450	265	2310	67
246A-3	R8	550	324	3300	65
293A-3	R8	550	324	3900	65
363A-3	R9	1150	677	4800	68
430A-3	R9	1150	677	6000	68
<i>U_n</i> = 500 V					
02A1-5	R1	44	26	30	46
03A0-5	R1	44	26	40	46
03A4-5	R1	44	26	52	46
04A8-5	R1	44	26	73	46
05A2-5	R1	44	26	94	46
07A6-5	R1	44	26	122	46
11A0-5	R1	44	26	172	46
014A-5	R2	88	52	232	51
021A-5	R2	88	52	337	51
027A-5	R3	134	79	457	57
034A-5	R3	134	79	562	57
040A-5	R4	134	79	667	62
052A-5	R4	280	165	907	62
065A-5	R5	280	165	1117	62
077A-5	R5	280	165	1120	62
096A-5	R6	435	256	1295	67
124A-5	R6	435	256	1440	67
156A-5	R7	450	265	1940	67
180A-5	R7	450	265	2310	67
240A-5	R8	550	324	3300	65
260A-5	R8	550	324	3900	65
302A-5	R9	1150	677	4200	68
361A-5	R9	1150	677	4800	68
414A-5	R9	1150	677	6000	68
<i>U_n</i> = 690 V					
07A4-7	R3	134	79	114	57
09A9-7	R3	134	79	143	57
14A3-7	R3	134	79	207	57
019A-7	R3	134	79	274	57
023A-7	R3	134	79	329	57
027A-7	R3	134	79	405	57
035A-7	R5	280	165	864	62
042A-7	R5	280	165	998	62

ACS880-01-...	Frame	Air flow		Heat dissipation	Noise
		m ³ /h	ft ³ /min	W	dB(A)
049A-7	R5	280	165	1120	62
061A-7	R6	435	256	1295	67
084A-7	R6	435	256	1440	67
098A-7	R7	450	265	1940	67
119A-7	R7	450	265	2310	67
142A-7	R8	550	324	3300	65
174A-7	R8	550	324	3900	65
210A-7	R9	1150	677	4200	68
271A-7	R9	1150	677	4800	68

Cooling air flow and heat dissipation for flange mounting (option +C135)

ACS880-01-...	Frame	Air flow (option +C135)		Heat dissipation (option +C135)	
		Heatsink	Front	Heatsink	Front
		m ³ /h	m ³ /h	W	W
$U_n = 230 \text{ V}$					
04A6-2	R1	44	9	57	16
06A6-2	R1	44	9	76	18
07A5-2	R1	44	9	101	21
10A6-2	R1	44	9	146	26
16A8-2	R2	88	16	195	37
24A3-2	R2	88	16	290	47
031A-2	R3	134	22	393	64
046A-2	R4	134	32	423	77
061A-2	R4	280	32	540	90
075A-2	R5	280	42	567	113
087A-2	R5	280	42	612	118
115A-2	R6	435	52	711	129
145A-2	R6	435	52	801	139
170A-2	R7	450	75	1089	171
206A-2	R7	450	75	1305	195
274A-2	R8	550	120	1845	255
$U_n = 400 \text{ V}$					
02A4-3	R1	44	9	18	12
03A3-3	R1	44	9	27	13
04A0-3	R1	44	9	38	14
05A6-3	R1	44	9	57	16
07A2-3	R1	44	9	76	18
09A4-3	R1	44	9	101	21

ACS880-01-...	Frame	Air flow (option +C135)		Heat dissipation (option +C135)	
		Heatsink	Front	Heatsink	Front
		m ³ /h	m ³ /h	W	W
12A6-3	R1	44	9	146	26
017A-3	R2	88	16	195	37
025A-3	R2	88	16	290	47
032A-3	R3	134	22	393	64
038A-3	R3	134	22	488	74
045A-3	R4	134	32	573	94
061A-3	R4	280	32	789	118
072A-3	R5	280	42	960	157
087A-3	R5	280	42	963	157
105A-3	R6	435	52	1121	175
145A-3	R6	435	52	1251	189
169A-3	R7	450	75	1701	239
206A-3	R7	450	75	2034	276
246A-3	R8	550	120	2925	375
293A-3	R8	550	120	3465	435
363A-3	R9	1150	170	4275	525
430A-3	R9	1150	170	5355	645
U_n = 500 V					
02A1-5	R1	44	9	18	12
03A0-5	R1	44	9	27	13
03A4-5	R1	44	9	38	14
04A8-5	R1	44	9	57	16
05A2-5	R1	44	9	76	18
07A6-5	R1	44	9	101	21
11A0-5	R1	44	9	146	26
014A-5	R2	88	16	195	37
021A-5	R2	88	16	290	47
027A-5	R3	134	22	393	64
034A-5	R3	134	22	488	74
040A-5	R4	134	32	573	94
052A-5	R4	280	32	789	118
065A-5	R5	280	42	960	157
077A-5	R5	280	42	963	157
096A-5	R6	435	52	1121	175
124A-5	R6	435	52	1251	189
156A-5	R7	450	75	1701	239
180A-5	R7	450	75	2034	276
240A-5	R8	550	120	2925	375
260A-5	R8	550	120	3465	435
302A-5	R9	1150	170	3735	465

ACS880-01-...	Frame	Air flow (option +C135)		Heat dissipation (option +C135)	
		Heatsink	Front	Heatsink	Front
		m ³ /h	m ³ /h	W	W
361A-5	R9	1150	170	4275	525
414A-5	R9	1150	170	5355	645
$U_n = 690 \text{ V}$					
07A4-7	R3	134	22	68	46
09A9-7	R3	134	22	92	51
14A3-7	R3	134	22	140	67
019A-7	R3	134	22	186	88
023A-7	R3	134	22	238	91
027A-7	R3	134	22	293	112
035A-7	R5	280	42	733	131
042A-7	R5	280	42	854	145
049A-7	R5	280	42	963	157
061A-7	R6	435	52	1121	175
084A-7	R6	435	52	1251	189
098A-7	R7	450	75	1701	239
119A-7	R7	450	75	2034	276
142A-7	R8	550	120	2925	375
174A-7	R8	550	120	3465	435
210A-7	R9	1150	170	3735	465
271A-7	R9	1150	170	4275	525

Connector and entry data for the power cables

■ IEC

Input, motor, resistor and DC cable terminal screw sizes, accepted wire sizes (per phase) and tightening torques (T) are given below. l denotes stripping length inside the connector.

Frame	Cable entries		L1, L2, L3, T1/U, T2/V, T3/W				Grounding terminals	
	pcs	\varnothing^*	Wire size	T (wire screw)		l	Max. wire size	T
		mm	mm ²	M...	N·m	mm	mm ²	N·m
R1	2	17	0.75...6	-	0.6	8	25	1.8
R2	2	17	0.75...6	-	0.6	8	25	1.8
R3	2	21	0.5...16	-	1.7	10	25	1.8
R4	2	24	0.5...35	-	3.3	18	25	2.9
R5	2	32	6...70	M8	5.6	18	35	2.9
R6	2	45	25...150	M10	30	30	185	9.8
R7	2	54	95...240 (25...150**)	M10	40 (30**)	30	185	9.8
R8	4	45	2 × (50...150)	M10	40	30	2×185	9.8

Frame	Cable entries		L1, L2, L3, T1/U, T2/V, T3/W			Grounding terminals		
	pcs	Ø *	Wire size	T (wire screw)		/	Max. wire size	T
		mm	mm ²	M...	N·m		mm	mm ²
R9	4	54	2 × (95...240)	M12	70	30	2×185	9.8

Frame	Cable entries		R-, R+/UDC+ and UDC- terminals			
	pcs	Ø *	Wire size	T (wire screw)		/
		mm	mm ²	M...	N·m	
R1	1	17	0.75...6	-	0.6	8
R2	1	17	0.75...6	-	0.6	8
R3	1	21	0.5...16	-	1.7	10
R4	1	24	0.5...35	-	3.3	18
R5	1	32	6...70	M8	5.6	18
R6	1	35	25...95	M8	20	30
R7	1	43	25...150	M10	30	30
R8	2	45	2 × (50...150)	M10	40	30
R9	2	54	2 × (95...240)	M12	70	30

* maximum cable diameter accepted. For the entry plate hole diameters, see chapter *Dimension drawings*.

** 525...690 V drives

Note: When you use a cable size smaller than what is accepted by the terminal, remove the terminal and use suitable cable lugs for connecting the cable directly under the head of the bolt.

■ UL

Input, motor, resistor and DC cable terminal screw sizes, accepted wire sizes (per phase) and tightening torques (T) in US units are given below. / denotes stripping length inside the connector

Frame	Cable entries		L1, L2, L3, T1/U, T2/V, T3/W			Grounding terminals		
	pcs	Ø *	Wire size	T (Wire screw)		/	Max. wire size	
		in.	kcmil/AWG	M...	lbf·ft		in.	AWG
R1	2	0.67	18...10	-	0.44	0.31	4	1.3
R2	2	0.67	18...10	-	0.44	0.31	4	1.3
R3	2	0.83	20...6	-	1.25	0.39	4	1.3
R4	2	0.94	20...2	-	2.4	0.70	4	2.1
R5	2	1.26	10...2/0	M8	4.1	0.70	2	2.1
R6	2	1.77	4...300 MCM	M10	22.1	1.18	350 MCM	7.2
R7	2	2.13	3/0...400 MCM (4...300 MCM)	M10	29.5 (22.1**)	1.18	350 MCM	7.2

Frame	Cable entries		L1, L2, L3, T1/U, T2/V, T3/W				Grounding terminals	
	pcs	Ø *	Wire size	T (Wire screw)		I	Max. wire size	lbf-ft
		in.	kcmil/AWG	M...	lbf-ft	in.	AWG	
R8	4	1.77	2 × (1/0...300 MCM)	M10	29.5	1.18	2× 350 MCM	7.2
R9	4	2.13	2 × (3/0...400 MCM)	M12	51.6	1.18	2× 350 MCM	7.2

Frame	Cable entries		R-, R+/UDC+ and UDC- terminals			
	pcs	Ø *	Wire size	T (wire screw)		I
		in.	kcmil/AWG	M...	lbf-ft	mm
R1	1	0.67	18...10	-	0.44	0.31
R2	1	0.67	18...10	-	0.44	0.31
R3	1	0.83	20...6	-	1.25	0.39
R4	1	0.94	20...2	-	2.4	0.70
R5	1	1.26	10...2/0	M8	4.1	1.18
R6	1	1.38	4...3/0	M8	14.8	1.18
R7	1	1.69	4...300 MCM	M10	22,1	1.18
R8	2	1.77	2 × (1/0...300 MCM)	M10	29.5	1.18
R9	2	2.13	2 × (3/0...400 MCM)	M12	51.6	1.18

* maximum cable diameter accepted. Cable connector inside diameter: 3/4" (frames R1 and R2), 1" (R3). For the entry plate hole diameters, see chapter *Dimension drawings*.

** 525...690 V drives

UL listed cable lugs and tools

Wire size	Compression lug		Crimping tool		
	Manufacturer	Type	Manufacturer	Type	No. of crimps
6	Thomas & Betts	E10731 54136	Thomas & Betts	TBM4S TBM45S	1
	Burndy	YAV6C-L2	Burndy	MY29-3	1
	IlSCO	CCL-6-38	IlSCO	ILC-10	2
4	Thomas & Betts	54140	Thomas & Betts	TBM4S	1
	Burndy	YA4C-L4BOX	Burndy	MY29-3	1
	IlSCO	CCL-4-38	IlSCO	MT-25	1
2	Thomas & Betts	54143TB 54142TB	Thomas & Betts	TBM4S TBM4S	1
	Burndy	YA2C-L4BOX	Burndy	MY29-3	2
	IlSCO	CRC-2	IlSCO	IDT-12	1
	IlSCO	CCL-2-38	IlSCO	MT-25	1

Wire size kcmil/AWG	Compression lug		Crimping tool		
	Manufacturer	Type	Manufacturer	Type	No. of crimps
1	Thomas & Betts	54148	Thomas & Betts	TBM-8	3
	Burndy	YA1C-L4BOX	Burndy	MY29-3	2
	IlSCO	CRA-1-38	IlSCO	IDT-12	1
	IlSCO	CCL-1-38	IlSCO	MT-25	1
1/0	Thomas & Betts	54109	Thomas & Betts	TBM-8	3
	Burndy	YA25-L4BOX	Burndy	MY29-3	2
	IlSCO	CRB-0	IlSCO	IDT-12	1
	IlSCO	CCL-1/0-38	IlSCO	MT-25	1
2/0	Thomas & Betts	54110	Thomas & Betts	TBM-8	3
	Burndy	YAL26T38	Burndy	MY29-3	2
	IlSCO	CRA-2/0	IlSCO	IDT-12	1
	IlSCO	CCL-2/0-38	IlSCO	MT-25	1

Connector data for the control cables

See chapter *Control unit*.

Typical power cable sizes

The table below gives copper and aluminum cable types with concentric copper shield for the drives with nominal current. For terminal and entry data for power cables, see [Connector and entry data for the power cables \(page 210\)](#).

Drive type ACS880-01-...	Frame size	IEC ¹⁾		UL (NEC) ²⁾	
		Cu cable type	Al cable type	Cu cable type	Al cable type
		mm ²	mm ²	AWG/kcmil	AWG/kcmil
$U_n = 230 \text{ V}$					
04A6-2	R1	3×1.5	-	14	-
06A6-2	R1	3×1.5	-	14	-
07A5-2	R1	3×1.5	-	14	-
10A6-2	R1	3×1.5	-	14	-
16A8-2	R2	3×6	-	10	-
24A3-2	R2	3×6	-	10	-
031A-2	R3	3×10	-	8	-
046A-2	R4	3×16	-	6	-
061A-2	R4	3×25	-	4	-
075A-2	R5	3×35	3×50	4	1
087A-2	R5	3×35	3×70	3	1/0
115A-2	R6	3×50	3×70	1/0	2/0
145A-2	R6	3×95	3×120	2/0	4/0
170A-2	R7	3×120	3×150	3/0	250 MCM
206A-2	R7	3×150	3×240	250 MCM	400 MCM
274A-2	R8	2 × (3×95) ³⁾	2 × (3×120)	2 × 2/0	2 × 250 MCM

214 Technical data

Drive type ACS880-01-...	Frame size	IEC ¹⁾		UL (NEC) ²⁾	
		Cu cable type	Al cable type	Cu cable type	Al cable type
		mm ²	mm ²	AWG/kcmil	AWG/kcmil
U_n = 400 V					
02A4-3	R1	3x1.5	-	14	-
03A3-3	R1	3x1.5	-	14	-
04A0-3	R1	3x1.5	-	14	-
05A6-3	R1	3x1.5	-	14	-
07A2-3	R1	3x1.5	-	14	-
09A4-3	R1	3x1.5	-	14	-
12A6-3	R1	3x1.5	-	14	-
017A-3	R2	3x6	-	10	-
025A-3	R2	3x6	-	10	-
032A-3	R3	3x10	-	8	-
038A-3	R3	3x10	-	8	-
045A-3	R4	3x16	-	6	-
061A-3	R4	3x25	-	4	-
072A-3	R5	3x35	3x50	3	1
087A-3	R5	3x35	3x70	3	1/0
105A-3	R6	3x50	3x70	1	2/0
145A-3	R6	3x95	3x120	2/0	4/0
169A-3	R7	3x120	3x150	3/0	250 MCM
206A-3	R7	3x150	3x240	250 MCM	400 MCM
246A-3	R8	2 × (3x70) ³⁾	2 × (3x95)	300 MCM	2 × 2/0
293A-3	R8	2 × (3x95) ³⁾	2 × (3x120)	2 × 3/0	2 × 250 MCM
363A-3	R9	2 × (3x120)	2 × (3x185)	2 × 4/0	2 × 300 MCM
430A-3	R9	2 × (3x150)	2 × (3x240)	2 × 250 MCM	2 × 400 MCM
U_n = 500 V					
02A1-5	R1	3x1.5	-	14	-
03A0-5	R1	3x1.5	-	14	-
03A4-5	R1	3x1.5	-	14	-
04A8-5	R1	3x1.5	-	14	-
05A2-5	R1	3x1.5	-	14	-
07A6-5	R1	3x1.5	-	14	-
11A0-5	R1	3x1.5	-	14	-
014A-5	R2	3x6	-	10	-
021A-5	R2	3x6	-	10	-
027A-5	R3	3x10	-	8	-
034A-5	R3	3x10	-	8	-
040A-5	R4	3x16	-	6	-
052A-5	R4	3x25	-	4	-
065A-5	R5	3x35	3x35	3	2
077A-5	R5	3x35	3x50	3	1

Drive type ACS880-01-...	Frame size	IEC ¹⁾		UL (NEC) ²⁾	
		Cu cable type	Al cable type	Cu cable type	Al cable type
		mm ²	mm ²	AWG/kcmil	AWG/kcmil
096A-5	R6	3x50	3x70	1	2/0
124A-5	R6	3x95	3x95	2/0	3/0
156A-5	R7	3x120	3x150	3/0	250 MCM
180A-5	R7	3x150	3x185	250 MCM	300 MCM
240A-5	R8	2 × (3x70) ³⁾	2 × (3x95)	300 MCM	2 × 2/0
260A-5	R8	2 × (3x70) ³⁾	2 × (3x95)	2 × 2/0	2 × 3/0
302A-5	R9	2 × (3x95)	2 × (3x120)	2 × 3/0	2 × 250 MCM
361A-5	R9	2 × (3x120)	2 × (3x185)	2 × 250 MCM	2 × 300 MCM
414A-5	R9	2 × (3x150)	2 × (3x240)	2 × 250 MCM	2 × 400 MCM
$U_n = 690 \text{ V}$					
07A4-7	R3	3x1.5	-	14	-
09A9-7	R3	3x1.5	-	14	-
14A3-7	R3	3x2.5	-	14	-
019A-7	R3	3x4	-	12	-
023A-7	R3	3x6	-	10	-
027A-7	R3	3x10	-	8	-
035A-7	R5	3x10	3x25	8	6
042A-7	R5	3x16	3x25	6	4
049A-7	R5	3x16	3x25	6	4
061A-7	R6	3x25	3x35	4	3
084A-7	R6	3x35	3x50	3	2
098A-7	R7	3x50	3x70	2	1/0
119A-7	R7	3x70	3x95	1/0	3/0
142A-7	R8	3x95 ³⁾	3x120	2/0	4/0
174A-7	R8	3x120 ³⁾	3x150	4/0	300 MCM
210A-7	R9	3x185	2 × (3x95)	300 MCM	2 × 3/0
271A-7	R9	3x240	2 × (3x120)	400 MCM	2 × 4/0

1) The cable sizing is based on max. 9 cables laid on a cable ladder side by side, three ladder type trays one on top of the other, ambient temperature 30 °C, PVC insulation, surface temperature 70 °C (EN 60204-1 and IEC 60364-5-52/2001). For other conditions, size the cables according to local safety regulations, appropriate input voltage and the load current of the drive. See also [Connector and entry data for the power cables \(page 210\)](#) for the accepted cable sizes of the drive.

2) The cable sizing is based on NEC Table 310-16 for copper wires, 75 °C (167 °F) wire insulation at 40 °C (104 °F) ambient temperature. Not more than three current-carrying conductors in raceway or cable or earth (directly buried). For other conditions, size the cables according to local safety regulations, appropriate input voltage and the load current of the drive. See also [UL \(page 211\)](#) for the accepted cable sizes of the drive.

3) The biggest cable size accepted by the connection terminals of frame R8 is 2 × (3x150). Biggest possible cable size is 3x240 or 400 MCM if the terminal type is changed and the cable entry box is not used.

Electrical power network specification

Voltage (U_1)	ACS880-01-xxxx-2 drives: 208 ... 240 V AC 3-phase +10%...-15%. This is indicated in the type designation label as typical input voltage level 3~230 V AC. ACS880-01-xxxx-3 drives: 380 ... 415 V AC 3-phase +10%...-15%. This is indicated in the type designation label as typical input voltage level 3~400 V AC. ACS880-01-xxxx-5 drives: 380 ... 500 V AC 3-phase +10%...-15%. This is indicated in the type designation label as typical input voltage levels 3~400/480/500 V AC. ACS880-01-xxxx-7 drives: 525 ... 690 V AC 3-phase +10%...-15%. This is indicated in the type designation label as typical input voltage levels 3~525/600/690 V AC.
Network type	TN (grounded) and IT (ungrounded) systems. However, 690 V drives must not be installed on corner-grounded or midpoint-grounded delta systems.
Rated conditional short-circuit current I_{cc} (IEC 61439-1)	65 kA when protected by fuses given in the fuse tables
Short-circuit current protection rating (UL 61800-5-1, CSA C22.2 No.274-17) Drive Frames R1-R8	US and Canada: The drive is suitable for use on a circuit capable of delivering not more than 100 kA symmetrical amperes rms at 600 V maximum when protected by fuses given in the fuse table.
Short-circuit current protection rating (UL 508C, CSA C22.2 No.274-17) Drive Frame R9	
Short-circuit current protection rating (UL 61800-5-1, CSA C22.2 No.274-17) Drive Frames R1-R8	US and Canada: The drive is suitable for use on a circuit capable of delivering not more than 65 kA symmetrical amperes rms at 480 V maximum when protected by circuit breakers given in the circuit breaker table.
Frequency (f_1)	50/60 Hz, variation $\pm 5\%$, maximum rate of change 17%/s
Imbalance	Max. $\pm 3\%$ of nominal phase to phase input voltage
Fundamental power factor ($\cos \phi_1$)	0.98 (at nominal load)

Motor connection data

Motor types	Asynchronous AC induction motors, permanent magnet synchronous motors, AC induction servomotors and ABB synchronous reluctance motors (SynRM motors)
Voltage (U_2)	0 to U_1 , 3-phase symmetrical. This is indicated in the type designation label as typical output voltage level as 3 0... U_1 , U_{max} at the field weakening point.
Frequency (f_2)	0...500 Hz <u>For drives with du/dt filter:</u> 120 Hz <u>For drives with sine filter:</u> 120 Hz
Current	See section <i>Ratings</i> .
Maximum recommended motor cable length	For ACS880-01-xxxx-2, ACS880-01-xxxx-3 and ACS880-01-xxxx-5 frames R1 to R3 and for types ACS880-01-07A3-7, ACS880-01-09A8-7, ACS880-01-14A2-7 and ACS880-01-018A-7: 150 m (492 ft). For ACS880-01-xxxx-2, ACS880-01-xxxx-3 and ACS880-01-xxxx-5 frames R4 to R9 and for types from ACS880-01-022A-7 to ACS880-01-271A-7: 300 m (984 ft). Note 1: With motor cables longer than 150 m (492 ft) or switching frequencies higher than default, the EMC Directive requirements may not be fulfilled. Note 2: Longer motor cables cause a motor voltage decrease which limits the available motor power. The decrease depends on the motor cable length and characteristics. Contact ABB for more information. Note that a sine filter (optional) at the drive output also causes a voltage decrease.

Efficiency

Approximately 98% at nominal power level.

Protection classes

Degree of protection (IEC/EN 60529)	IP21, IP55. Option +P940 and +P944: IP20
Enclosure type (UL 50/50E)	UL Type 1, UL Type 12. Option +P940: UL Open Type. For indoor use only.
Overvoltage category (IEC 60664-1)	III
Protective class (IEC/EN 61800-5-1)	I

Ambient conditions

Environmental limits for the drive are given below. The drive is to be used in a heated, indoor, controlled environment.

	Operation installed for stationary use	Storage in the protective package	Transportation in the protective package
Installation site altitude	0 to 4000 m (13123 ft) above sea level ¹⁾ Above 1000 m (3281 ft) ²⁾ : see section <i>Derating</i> (page 173).	-	-
Air temperature	-15 to +55 °C (5 to 131 °F). No frost allowed. See section <i>Derating</i> (page 173).	-40 to +70 °C (-40 to +158 °F)	-40 to +70 °C (-40 to +158 °F)
Relative humidity	5 to 95%	Max. 95%	Max. 95%
	No condensation allowed. Maximum allowed relative humidity is 60% in the presence of corrosive gases.		
Contamination (IEC 60721-3-3, IEC 60721-3-2, IEC 60721-3-1)	IEC/EN 60721-3-3:2002: Classification of environmental conditions- Part 3-3: Classification of groups of environmental parameters and their severities - Stationary use of weather protected locations	IEC 60721-3-1:1997	IEC 60721-3-2:1997
Chemical gases	Class 3C2	Class 1C2	Class 2C2
Solid particles	Class 3S2. No conductive dust allowed.	Class 1S3	Class 2S2
Pollution degree	2		
Atmospheric pressure	70 to 106 kPa 0.7 to 1.05 atmospheres	70 to 106 kPa 0.7 to 1.05 atmospheres	60 to 106 kPa 0.6 to 1.05 atmospheres
Vibration EN 60068-2-6:2008	Max. 1 mm (0.04 in.) (5 to 13.2 Hz), max. 7 m/s ² (23 ft/s ²) (13.2 to 100 Hz) sinusoidal	Max. 1 mm (0.04 in.) (5 to 13.2 Hz), max. 7 m/s ² (23 ft/s ²) (13.2 to 100 Hz) sinusoidal	Max. 3.5 mm (0.14 in.) (2 to 9 Hz), max. 15 m/s ² (49 ft/s ²) (9 to 200 Hz) sinusoidal

Vibration (ISTA)	-	R1...R5 (ISTA 1A): Displacement, 25 mm peak to peak, 14200 vibratory impacts R6...R9 (ISTA 3E): Random, overall Grms level of 0.54																
Shock/Drop (ISTA)	Not allowed	R1...R5 (ISTA 1A): Drop, 6 faces, 3 edges and 1 corner <table border="1"> <thead> <tr> <th>Weight range</th> <th>mm</th> <th>in.</th> </tr> </thead> <tbody> <tr> <td>0...10 kg (0...22 lb)</td> <td>760</td> <td>29.9</td> </tr> <tr> <td>10...19 kg (22...42 lb)</td> <td>610</td> <td>24.0</td> </tr> <tr> <td>19...28 kg (42...62 lb)</td> <td>460</td> <td>18.1</td> </tr> <tr> <td>28...41 kg (62...90 lb)</td> <td>340</td> <td>13.4</td> </tr> </tbody> </table> R6...R9 (ISTA 3E): Shock, incline impact: 1.2 m/s (3.94 ft/s) Shock, rotational edge drop: 230 mm (7.9 in)	Weight range	mm	in.	0...10 kg (0...22 lb)	760	29.9	10...19 kg (22...42 lb)	610	24.0	19...28 kg (42...62 lb)	460	18.1	28...41 kg (62...90 lb)	340	13.4	With packing max. 100 m/s ² (330 ft/s ²), 11 ms
Weight range	mm	in.																
0...10 kg (0...22 lb)	760	29.9																
10...19 kg (22...42 lb)	610	24.0																
19...28 kg (42...62 lb)	460	18.1																
28...41 kg (62...90 lb)	340	13.4																

1. For neutral-grounded TN and TT systems and non-corner grounded IT systems.
2. For corner-grounded TN, TT and IT systems.

Materials

Drive enclosure	<ul style="list-style-type: none"> • PC/ABS 3 mm, color NCS 1502-Y (RAL 9002 / PMS 1C Cool Grey) and RAL 9017 • PC+10% GF 3.0 mm, Color RAL 9017 (in frames R1 to R3 only) • Plastic parts are made of UV resistant f1 classified plastics • hot-dip zinc coated steel sheet 1.5 to 2.5 mm, thickness of coating 100 micrometers, color NCS 1502-Y
Package	Plywood and cardboard. Foam cushions PP-E, bands PP.
Disposal	The main parts of the drive can be recycled to preserve natural resources and energy. Product parts and materials should be dismantled and separated. Generally all metals, such as steel, aluminum, copper and its alloys, and precious metals can be recycled as material. Plastics, rubber, cardboard and other packaging material can be used in energy recovery. Printed circuit boards and large electrolytic capacitors need selective treatment according to IEC 62635 guidelines. To aid recycling, plastic parts are marked with an appropriate identification code. Contact your local ABB distributor for further information on environmental aspects and recycling instructions for professional recyclers. End of life treatment must follow international and local regulations.

Applicable standards

The drive complies with the following standards. The compliance with the European Low Voltage Directive is verified according to standard EN 61800-5-1.







EN 61800-5-1:2007	<i>Adjustable speed electrical power drive systems. Part 5-1: Safety requirements – Electrical, thermal and energy</i>
IEC 61800-5-2:2016 EN 61800-5-2:2007	<i>Adjustable speed electrical power drive systems. Part 5-2: Safety requirements – Functional</i>
IEC 61508-1:2010	<i>Functional safety of electrical/electronic/programmable electronic safety-related systems - Part 1: General requirements</i>
IEC 61508-2:2010	<i>Functional safety of electrical/electronic/programmable electronic safety-related systems - Part 2: Requirements for electrical/electronic/programmable electronic safety-related systems</i>
EN 62061:2005 +AC:2010 +A1:2013 + A2:2015	<i>Safety of machinery. Functional safety of safety-related electrical, electronic and programmable electronic control systems</i>
EN/ISO 13849-1:2015	<i>Safety of machinery — Safety-related parts of control systems — Part 1: General principles for design</i>
EN/ISO 13849-2:2012	<i>Safety of machinery — Safety-related parts of control systems — Part 2: Validation</i>
IEC 60146-1-1:2009 EN 60146-1-1:2010	<i>Semiconductor converters – General requirements and line commutated converters – Part 1-1: Specification of basic requirements</i>
EN 60204-1:2006 + A1 2009 + AC:2010	<i>Safety of machinery. Electrical equipment of machines. Part 1: General requirements.</i> Provisions for compliance: The final assembler of the machine is responsible for installing: <ul style="list-style-type: none"> • emergency-stop device • supply disconnecting device
EN 60529:1991 + A2:2013	<i>Degrees of protection provided by enclosures (IP code)</i>
IEC 60664-1:2007	<i>Insulation coordination for equipment within low-voltage systems. Part 1: Principles, requirements and tests</i>
EN 61800-3:2004 + A1:2012	<i>Adjustable speed electrical power drive systems. Part 3: EMC requirements and specific test methods</i>
EN 50581:2012	<i>Technical documentation for the assessment of electrical and electronic products with respect to the restriction of hazardous substances</i>
IEC/EN 63000:2018	<i>Technical documentation for the assessment of electrical and electronic products with respect to the restriction of hazardous substances</i>
UL 61800-5-1: First Edition	<i>Standard for Safety, Adjustable Speed Electrical Power Drive Systems – Part 5-1: Safety Requirements – Electrical, Thermal and Energy</i> Frames R1...R8
CSA C22.2 No. 274-17	<i>Adjustable speed drives</i>
UL 508C:2002	<i>Standard for Safety, Power Conversion Equipment, third edition</i> Frame R9
CSA C22.2 No. 22-10	<i>General Requirements - Canadian Electrical Code, Part II</i>

Markings

These markings are attached to the drive:

	CE mark Product complies with the applicable European Union legislation. For fulfilling the EMC requirements, see the additional information concerning the drive EMC compliance (IEC/EN 61800-3).
-------------------------------------------------------------------------------------	-------------------------------------------------------------------------------------------------------------------------------------------------------------------------------------------------------

	TÜV Safety Approved mark (functional safety) Product contains Safe Torque Off and possibly other (optional) safety functions which are certified by TÜV according to the relevant functional safety standards. Applicable to drives and inverters; not applicable to supply, brake or DC/DC converter units or modules.
-------------------------------------------------------------------------------------	----------------------------------------------------------------------------------------------------------------------------------------------------------------------------------------------------------------------------------------------------------------------------------------------------------------------------

	<p>UL Listed mark for USA and Canada Product has been tested and evaluated against the relevant North American standards by the Underwriters Laboratories. Valid with rated voltages up to 600 V.</p>
	<p>CSA certification mark for USA and Canada Product has been tested and evaluated against the relevant North American standards by the CSA Group. Valid with rated voltages up to 600 V.</p>
	<p>EAC (Eurasian Conformity) mark Product complies with the technical regulations of the Eurasian Customs Union. EAC mark is required in Russia, Belarus and Kazakhstan.</p>
	<p>KC mark Product complies with Korea's product safety requirements for electrical and electronic equipment and components that utilize power from 50...1000 V AC.</p>
	<p>Electronic Information Products (EIP) green mark The product complies with <i>the People's Republic of China Electronic Industry Standard (SJ/T 11364-2014)</i>. The product does not contain toxic and hazardous substances or elements above the maximum concentration values, and it is an environmentally-friendly product which can be recycled.</p>
	<p>WEEE mark At the end of life the product should enter the recycling system at an appropriate collection point and not placed in the normal waste stream.</p>

Compliance with the EN 61800-3:204 + A1:2012

■ Definitions

EMC stands for Electromagnetic Compatibility. It is the ability of electrical/electronic equipment to operate without problems within an electromagnetic environment. Likewise, the equipment must not disturb or interfere with any other product or system within its locality.

First environment includes establishments connected to a low-voltage network which supplies buildings used for domestic purposes.

Second environment includes establishments connected to a network not supplying domestic premises.

Drive of category C1: drive of rated voltage less than 1000 V and intended for use in the first environment.

Drive of category C2: drive of rated voltage less than 1000 V and intended to be installed and started up only by a professional when used in the first environment.

Note: A professional is a person or organization having necessary skills in installing and/or starting up power drive systems, including their EMC aspects.

Drive of category C3: drive of rated voltage less than 1000 V and intended for use in the second environment and not intended for use in the first environment.

Drive of category C4: drive of rated voltage equal to or above 1000 V, or rated current equal to or above 400 A, or intended for use in complex systems in the second environment.

■ Category C2

The emission limits are complied with the following provisions:

1. The drive is equipped with EMC filter +E202.
2. The motor and control cables are selected as specified in this manual.
3. The drive is installed according to the instructions given in this manual.
4. For the maximum motor cable length, see section *Motor connection data*.



WARNING! The drive may cause radio interference if used in residential or domestic environment. The user is required to take measures to prevent interference, in association to the requirements for the CE compliance listed above, if necessary.

Note: Note: Do not install a drive with the EMC filter +E202 connected to a system that the filter is not suitable for. This can cause danger, or damage the drive.

Note: Do not install a drive with the ground-to-phase varistor connected to a system that the varistor is not suitable for. If you do, the varistor circuit can be damaged. If you install the drive to any other system than symmetrically grounded TN-S system, you may need to disconnect the EMC filter or the ground-to-phase varistor. See *ACS880 frames R1 to R11 EMC filter and ground-to-phase varistor disconnecting instructions* ([3AUA0000125152](#) [English])

■ Category C3

The drive complies with the standard with the following provisions:

- The drive is equipped with EMC filter +E200.
- The motor and control cables are selected as specified in this manual.
- The drive is installed according to the instructions given in this manual.
- For the maximum motor cable length, see section *Motor connection data*.



WARNING! drive of category C3 is not intended to be used on a low-voltage public network which supplies domestic premises. Radio frequency interference is expected if the drive is used on such a network.

Note: Note: Do not install a drive with the EMC filter +E200 connected to a system that the filter is not suitable for. This can cause danger, or damage the drive.

Note: Do not install a drive with the ground-to-phase varistor connected to a system that the varistor is not suitable for. If you do, the varistor circuit can be damaged. If you install the drive to any other system than symmetrically grounded TN-S system, you may need to disconnect the EMC filter or the ground-to-phase varistor. See *ACS880 frames R1 to R11 EMC filter and ground-to-phase varistor disconnecting instructions* ([3AUA0000125152](#) [English])

■ **Category C4**

The drive complies with the C4 category with these provisions:

1. It is ensured that no excessive emission is propagated to neighboring low-voltage networks. In some cases, the natural suppression in transformers and cables is sufficient. If in doubt, the supply transformer with static screening between the primary and secondary windings can be used.

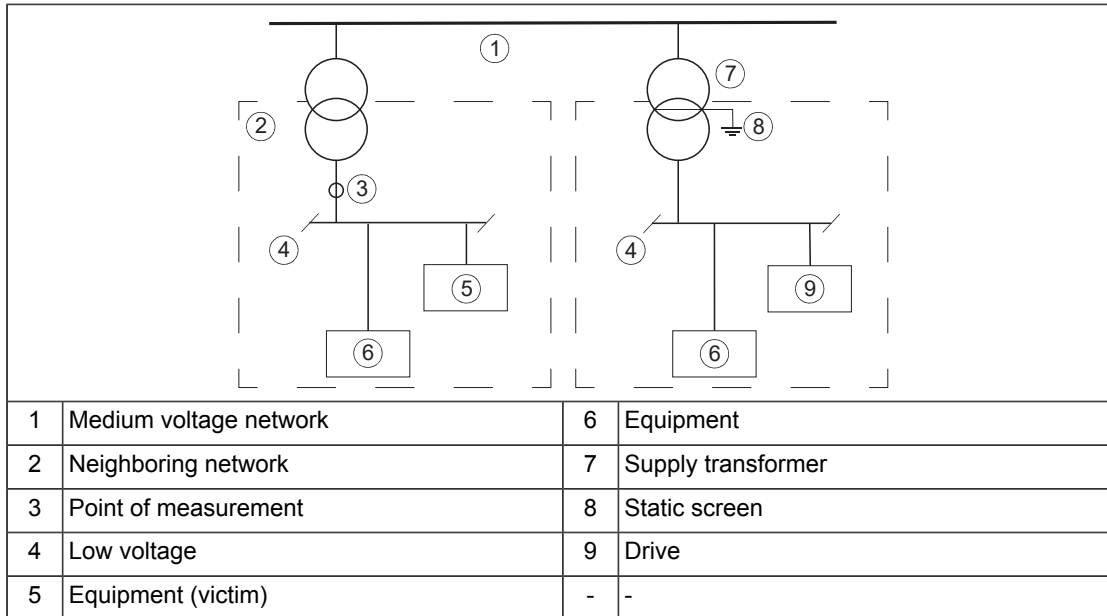

2. An EMC plan for preventing disturbances is drawn up for the installation. A template is available in *Technical guide No. 3 EMC compliant installation and configuration for a power drive system* (3AFE61348280 (English)).
3. The motor and control cables are selected, and routed according to the electrical planning guidelines of the drive. The EMC recommendations are obeyed.
4. The drive is installed according to its installation instructions. The EMC recommendations are obeyed.



WARNING!

A drive of category C4 is not intended to be used on a low-voltage public network which supplies domestic premises. Radio frequency interference is expected if the drive is used on such a network.

UL and CSA checklist



WARNING!

Operation of this drive requires detailed installation and operation instructions provided in the hardware and software manuals. The manuals are provided in electronic format in the drive package or on the Internet. Keep the manuals with the drive at all times. Hard copies of the manuals can be ordered through the manufacturer.

- Make sure that the drive type designation label includes the applicable marking.
- **DANGER - Risk of electric shock.** After disconnecting the input power, always wait for 5 minutes to let the intermediate circuit capacitors discharge before you start working on the drive, motor or motor cable.
- The drive is to be used in a heated, indoor controlled environment. The drive must be installed in clean air according to the enclosure classification. Cooling air must be clean, free from corrosive materials and electrically conductive dust.
- The maximum surrounding air temperature is 40 °C at rated output current. The output current is derated for 40 ... 55 °C.
- The drive is suitable for use in a circuit capable of delivering not more than 100 kA rms symmetrical amperes, 600 V maximum when protected by the UL fuses given elsewhere in this chapter.
- The drive is suitable for use in a circuit capable of delivering not more than 65 kA rms symmetrical amperes, 480 V maximum when protected by the UL circuit breakers given elsewhere in this chapter.
- The cables located within the motor circuit must be rated for at least 75 °C in UL-compliant installations.
- The input cable must be protected with fuses or circuit breakers. These protective devices provide branch circuit protection in accordance with the national regulations (National Electrical Code (NEC) or Canadian Electrical Code). Obey also any other applicable local or provincial codes.
Suitable UL fuses are listed in section [Fuses \(UL\) \(page 197\)](#) and circuit breakers in section [Circuit breakers \(UL\) \(page 202\)](#).

**WARNING!**

The opening of the branch-circuit protective device may be an indication that a fault current has been interrupted. To reduce the risk of fire or electric shock, current-carrying parts and other components of the device should be examined and replaced if damaged.

- The drive provides motor overload protection. This feature is not enabled when the drives leaves the ABB factory. For enabling this motor overload protection, see the firmware manual.
- The drive overvoltage category according to IEC 60664-1 is III.
- To maintain the environment integrity of the enclosure, replace the cable grommets with field-installed industrial conduit hubs or closure plates required by the enclosure type (or better).

Approvals

The drive is marine type approved. For more information, see *ACS880-01/04 +C132 marine type-approved drives supplement* ([3AXD50000010521](#) [English]).

Design lifetime expectancy

The design lifetime expectancy of the drive and its overall components exceeds ten (10) years in normal operating environments. In some cases, the drive can last 20 years or more. To achieve a long lifetime of the product the manufacturer's instructions for sizing the drive, installation, operational conditions and preventive maintenance schedule shall be followed.

Disclaimers

■ **Generic disclaimer**

The manufacturer shall have no obligation with respect to any product which (i) has been improperly repaired or altered; (ii) has been subjected to misuse, negligence or accident; (iii) has been used in a manner contrary to the manufacturer's instructions; or (iv) has failed as a result of ordinary wear and tear.

■ **Cybersecurity disclaimer**

This product is designed to be connected to and to communicate information and data via a network interface. It is Customer's sole responsibility to provide and continuously ensure a secure connection between the product and Customer network or any other network (as the case may be). Customer shall establish and maintain any appropriate measures (such as but not limited to the installation of firewalls, application of authentication measures, encryption of data, installation of anti-virus programs, etc) to protect the product, the network, its system and the interface against any kind of security breaches, unauthorized access, interference, intrusion, leakage and/or theft of data or information. ABB and its affiliates are not liable for damages and/or losses related to such security breaches, any unauthorized access, interference, intrusion, leakage and/or theft of data or information.

14

Dimension drawings

Contents of this chapter

This chapter contains dimension drawings of the standard drive (IP21, UL Type 1) and drive with option +B056 (IP55, UL Type 12).

For dimension drawings with options +P940 and +P944 (IP20, UL Open Type), see *ACS880...+P940 and +P944 drive modules supplement* ([3AUA0000145446](#) [English]).

Frame R1 (IP21, UL Type 1)

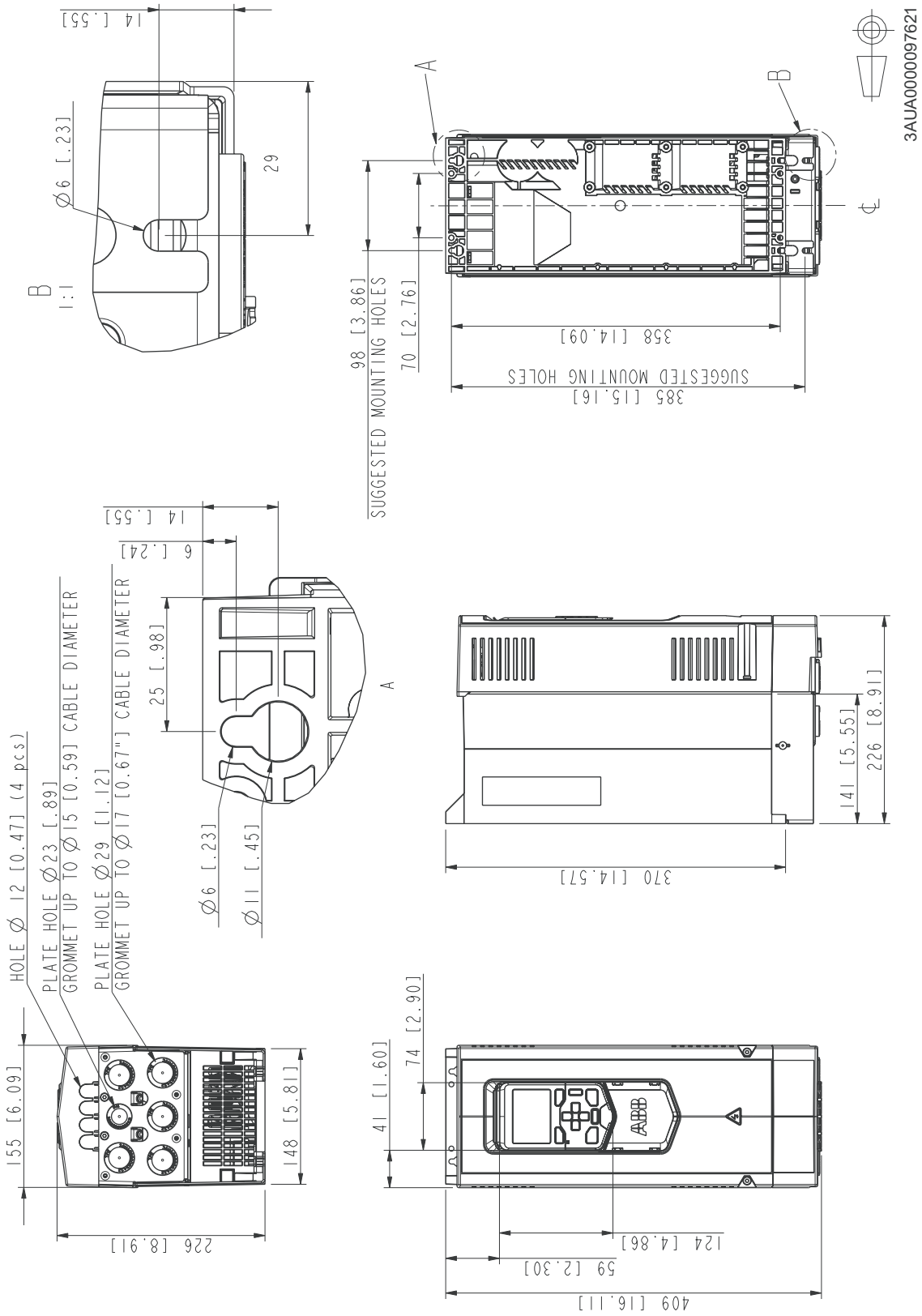

Frame R1 (IP55, UL Type 12)

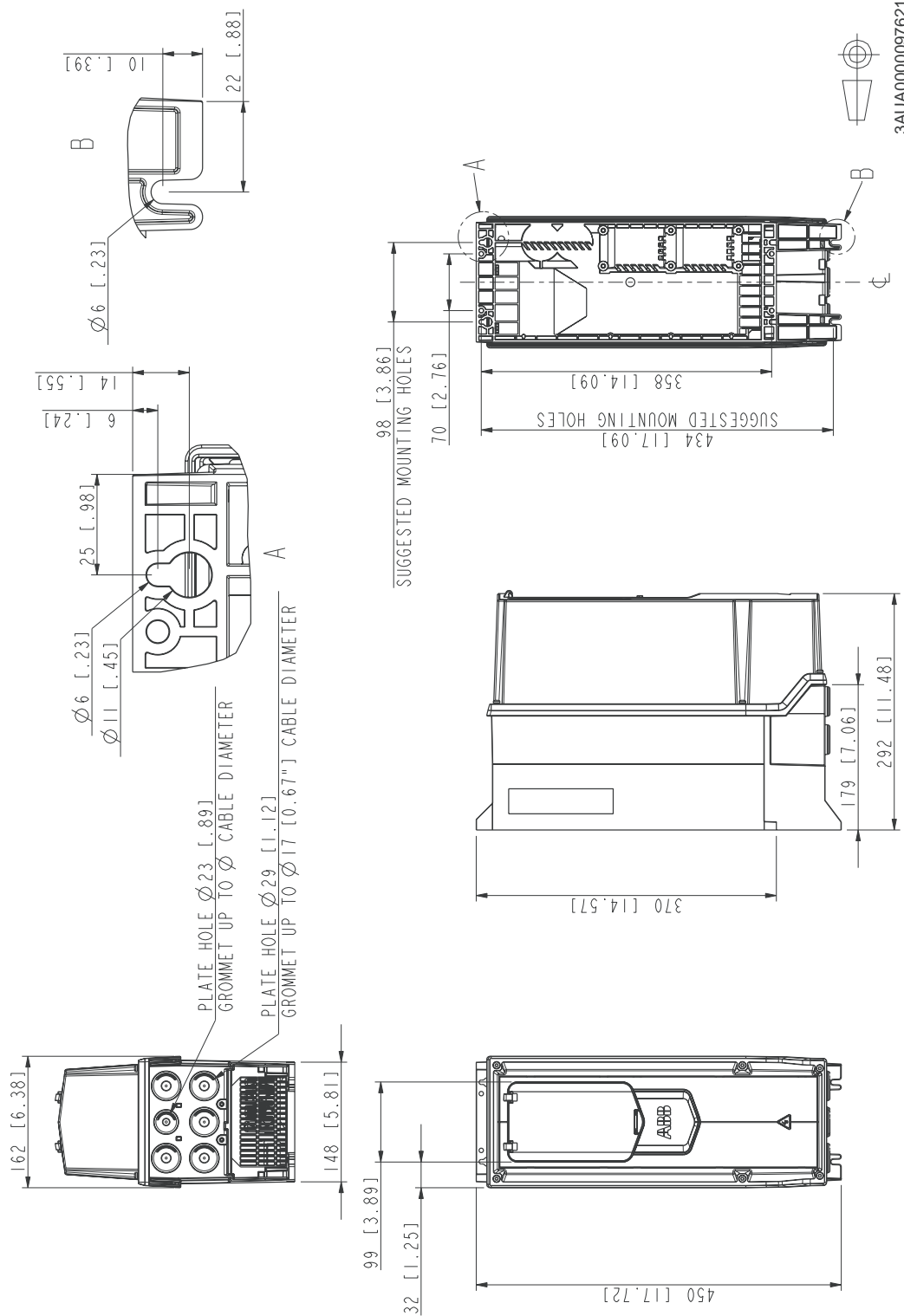

Frame R2 (IP21, UL Type 1)

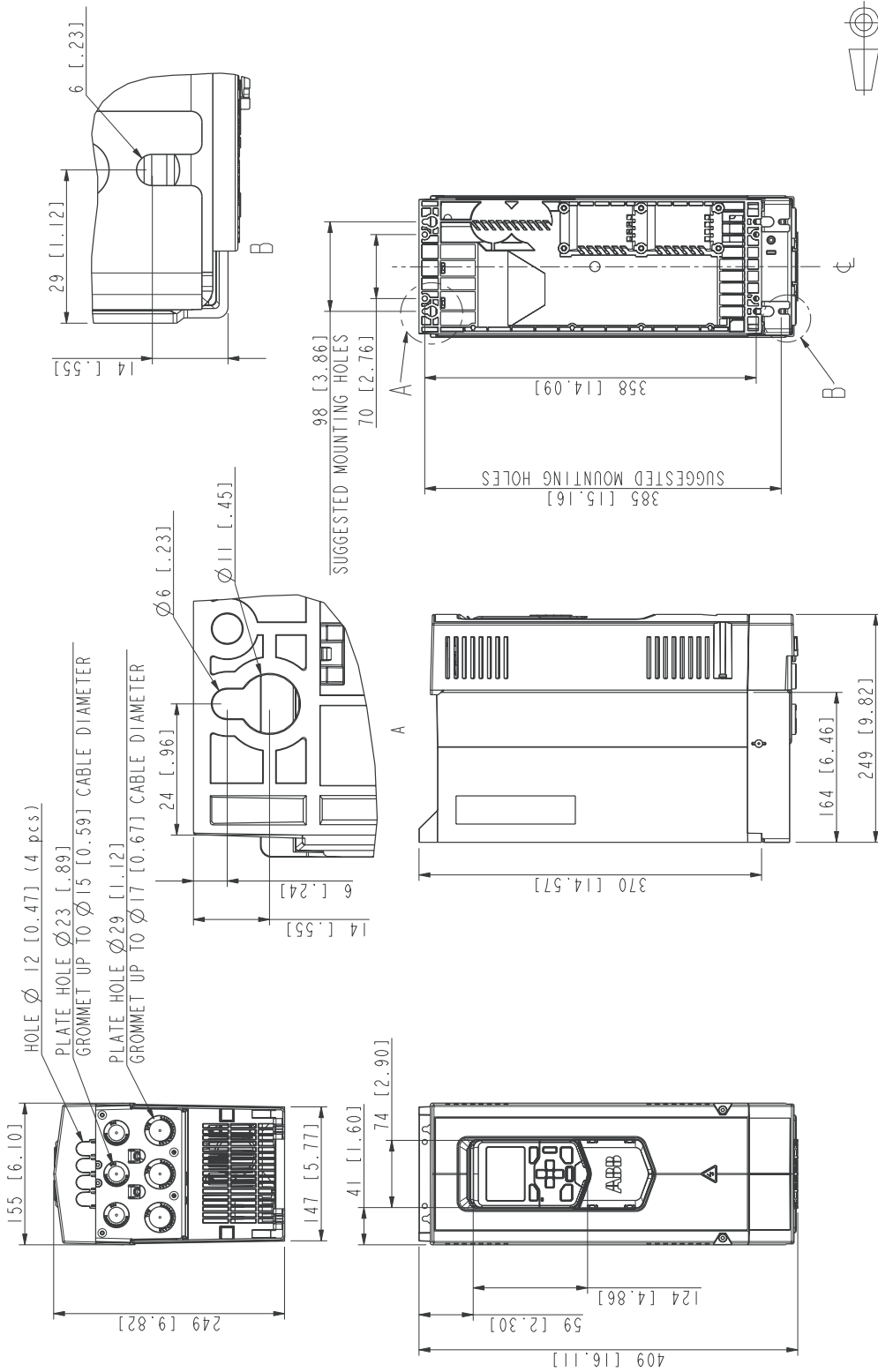

3AUA0000097691

Frame R2 (IP55, UL Type 12)

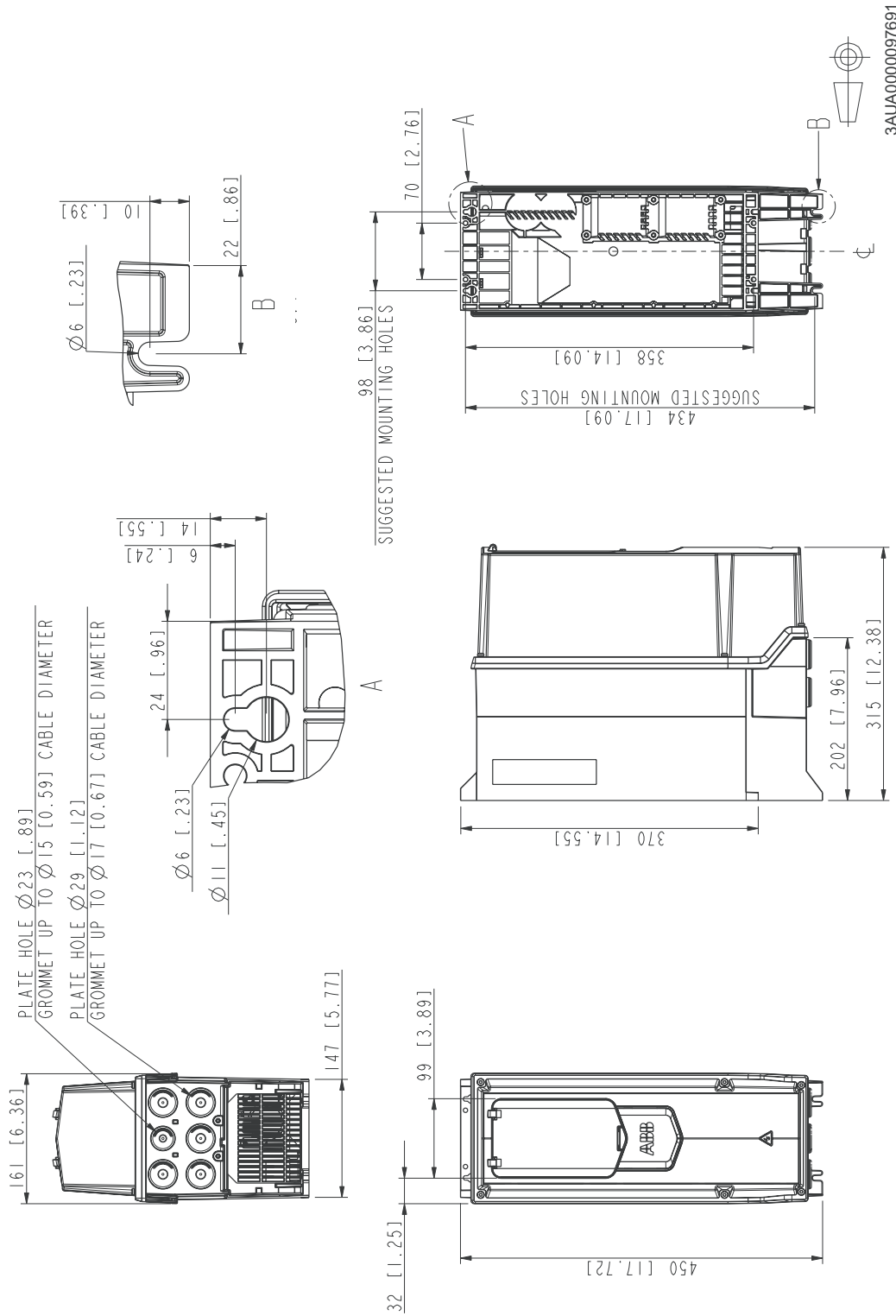

Frame R3 (IP21, UL Type 1)

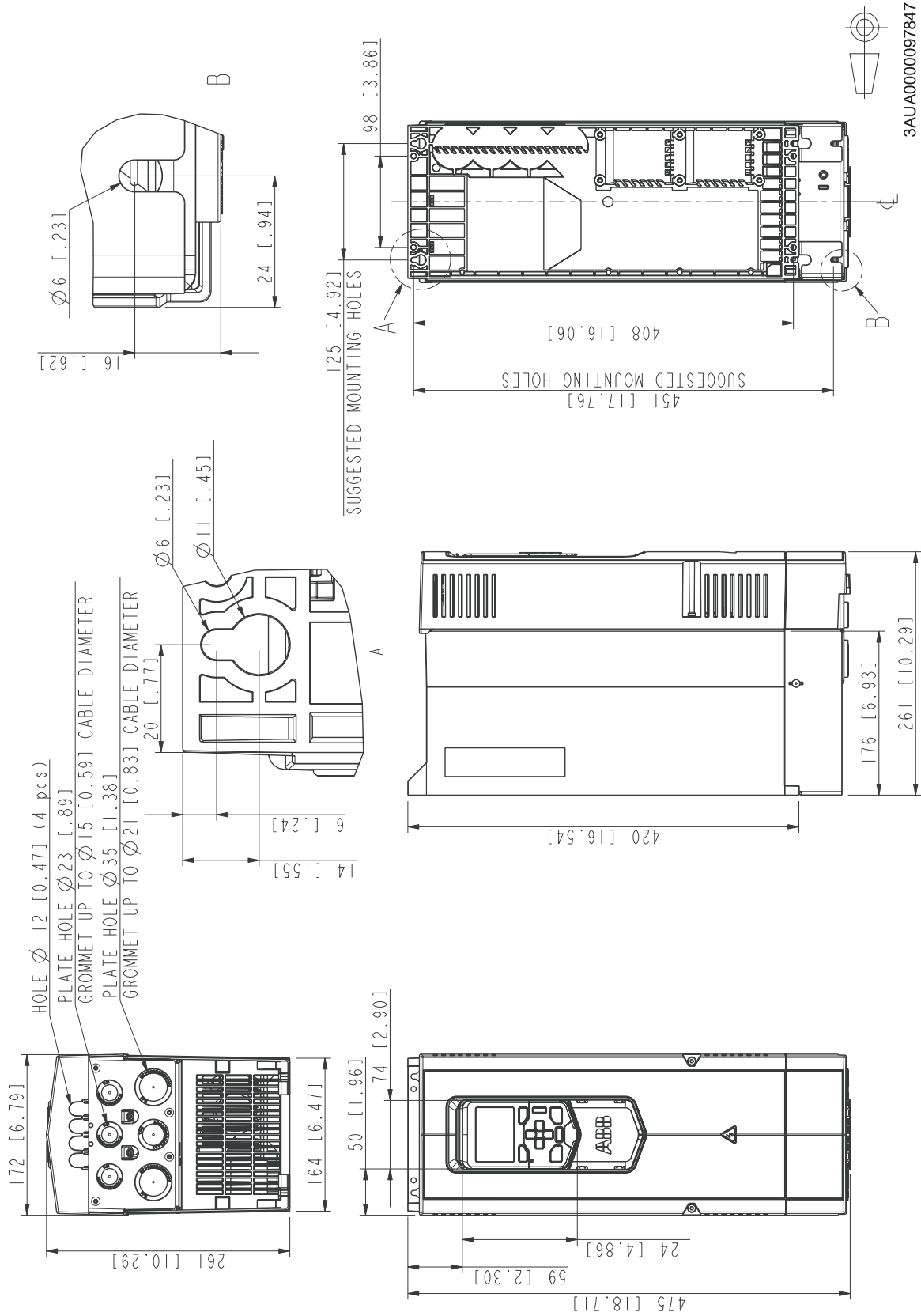

Frame R3 (IP55, UL Type 12)

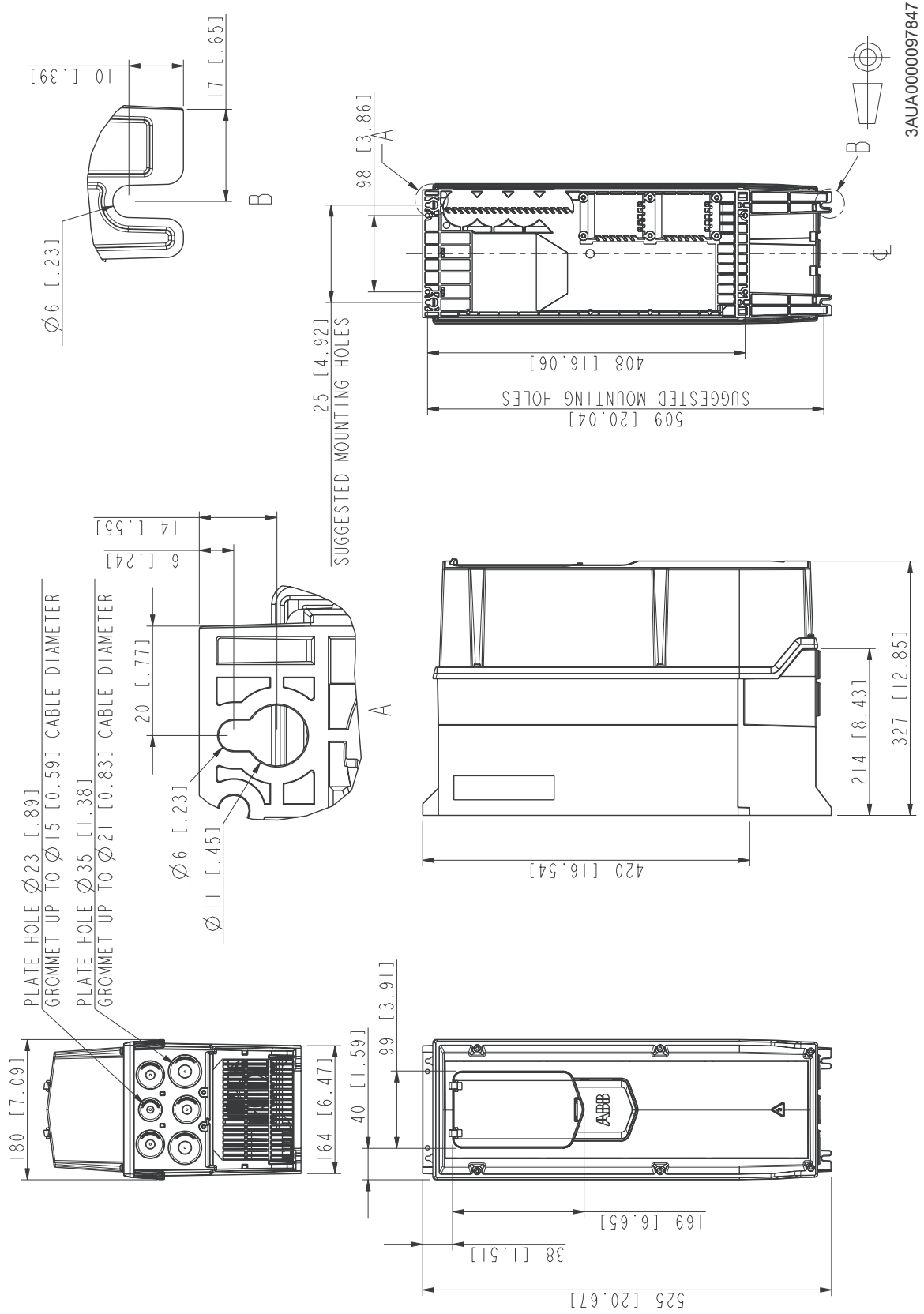

Frame R4 (IP21, UL Type 1)

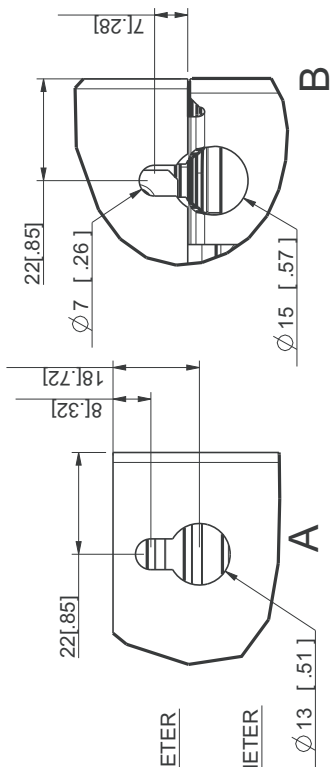
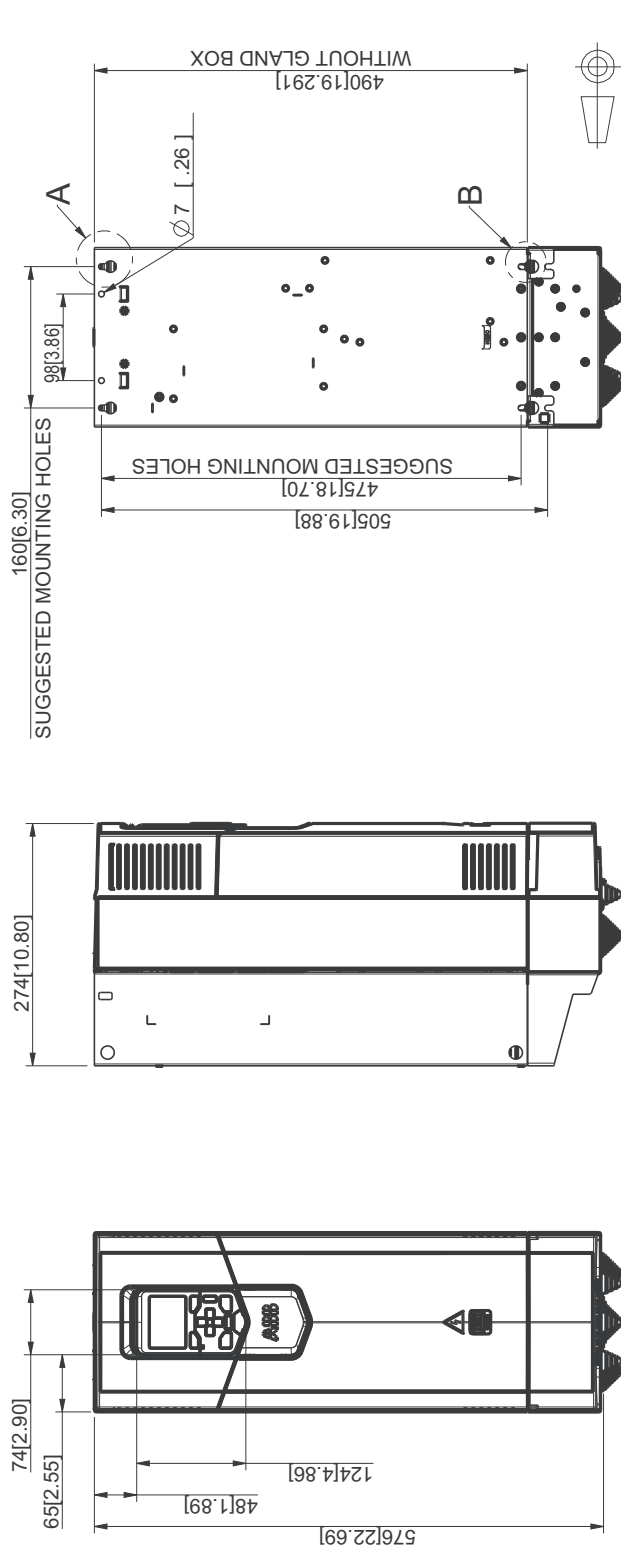
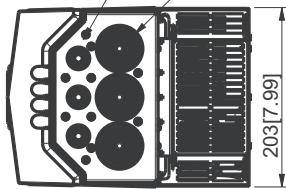

PLATE HOLE $\phi 22$ [0.87] (3pcs.)
GROMMET UP TO $\phi 15$ [0.59] CABLE DIAMETER

PLATE HOLE $\phi 44$ [1.73] (3pcs.)
GROMMET UP TO $\phi 24$ [0.94] CABLE DIAMETER



3AUA0000098285

Frame R4 (IP55, UL Type 12)

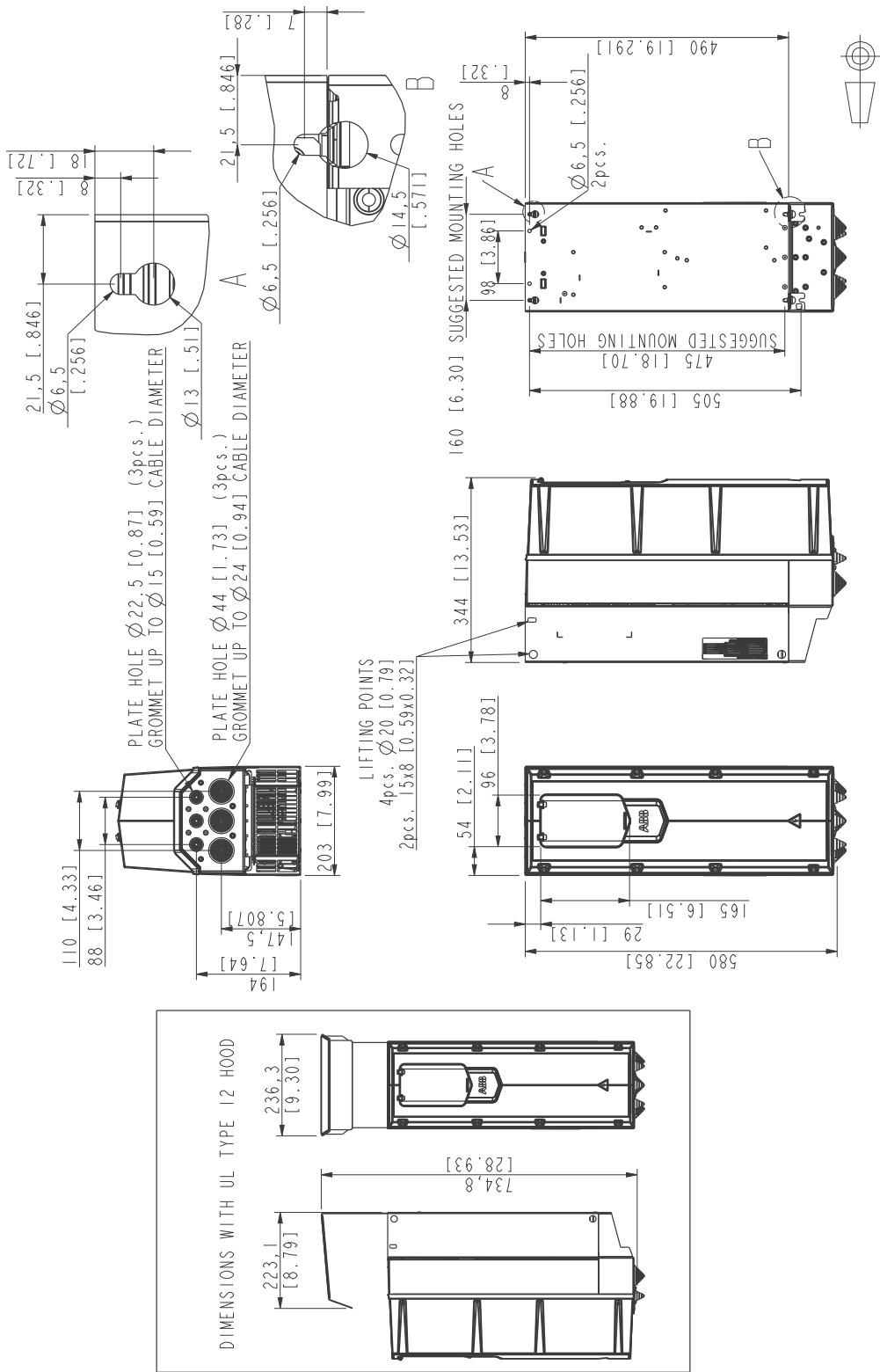

3AUA0000098285

Frame R5 (IP21, UL Type 1)

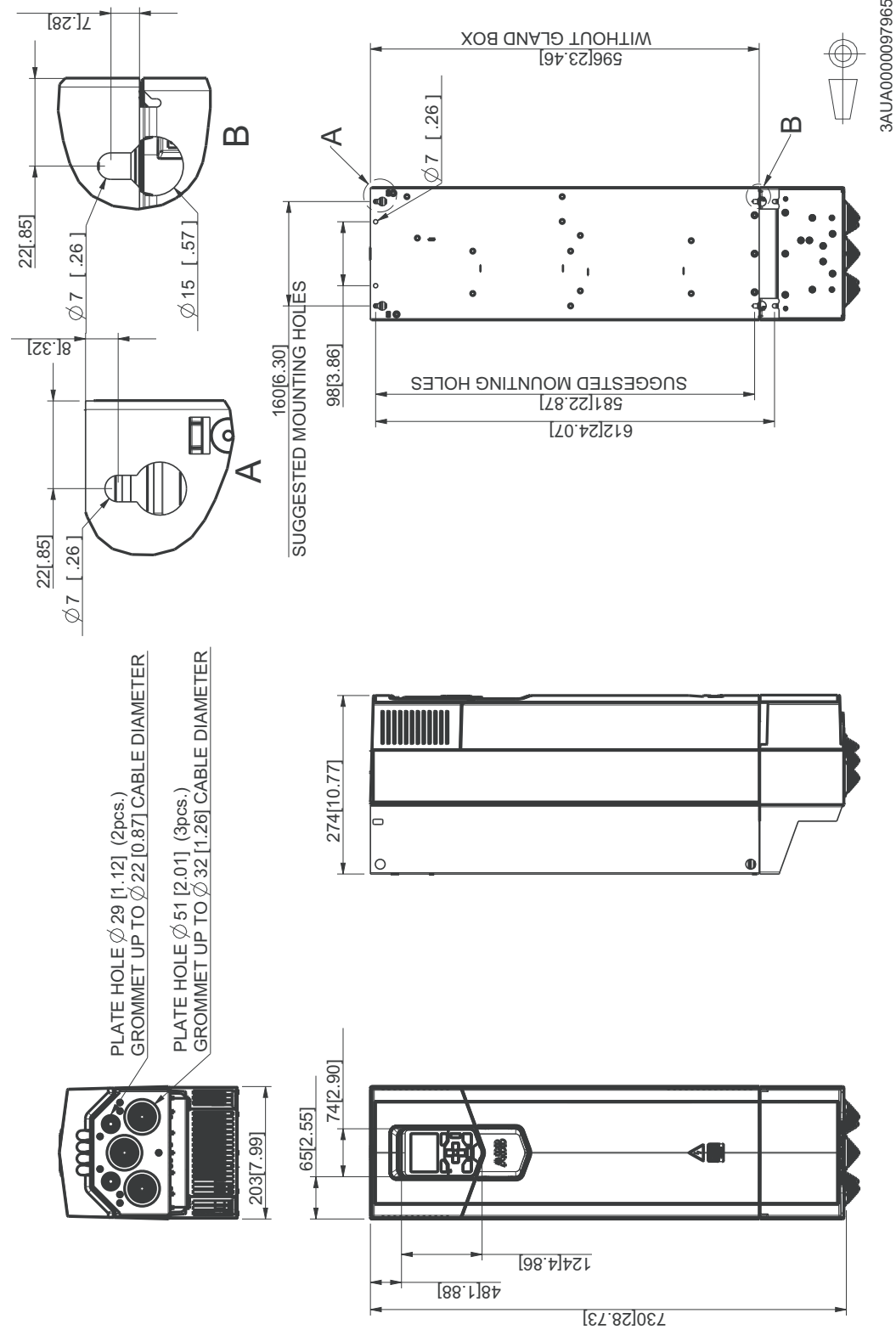

Frame R6 (IP21, UL Type 1)

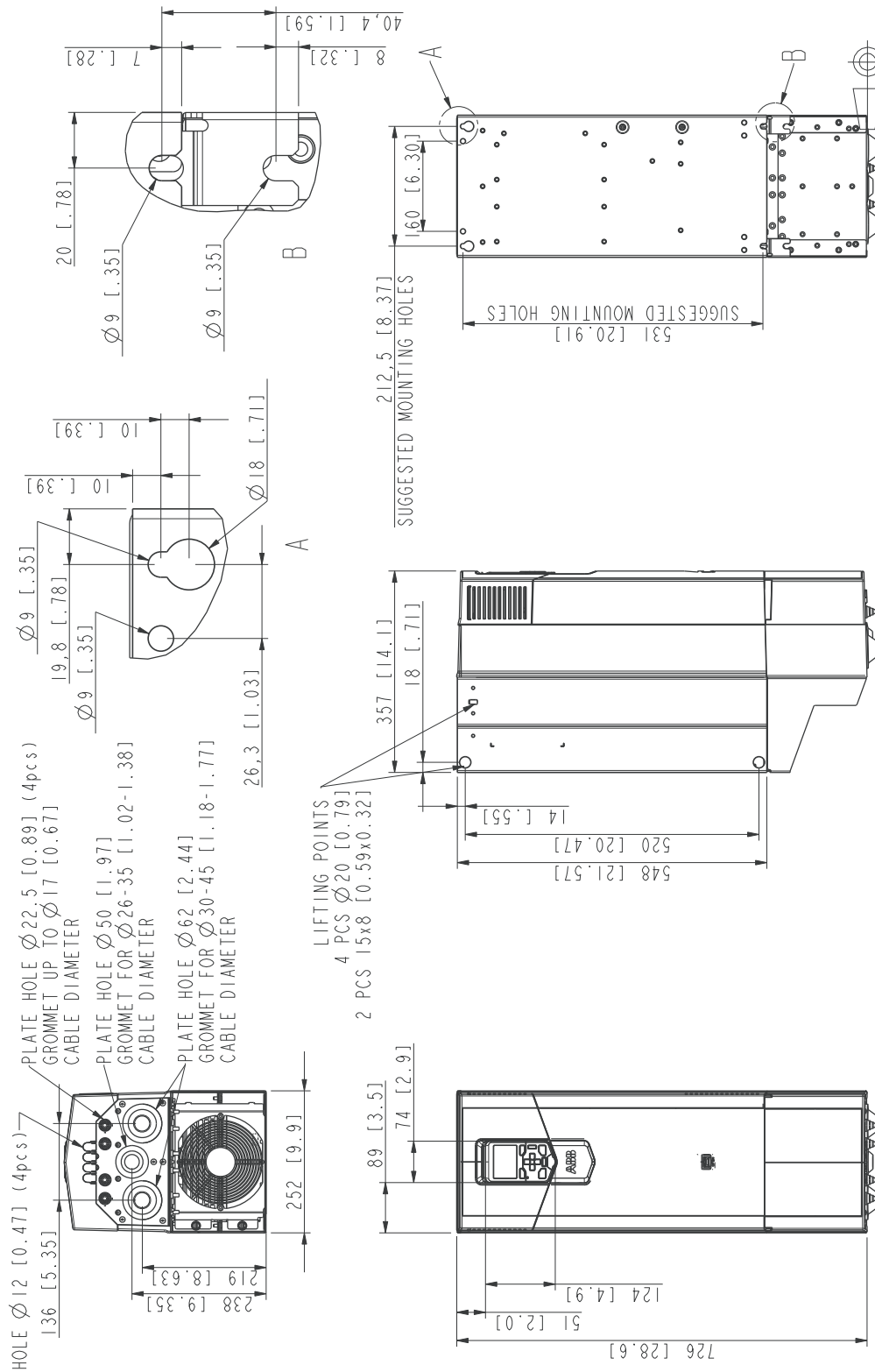

3AUA0000098321

Frame R6 (IP55, UL Type 12)

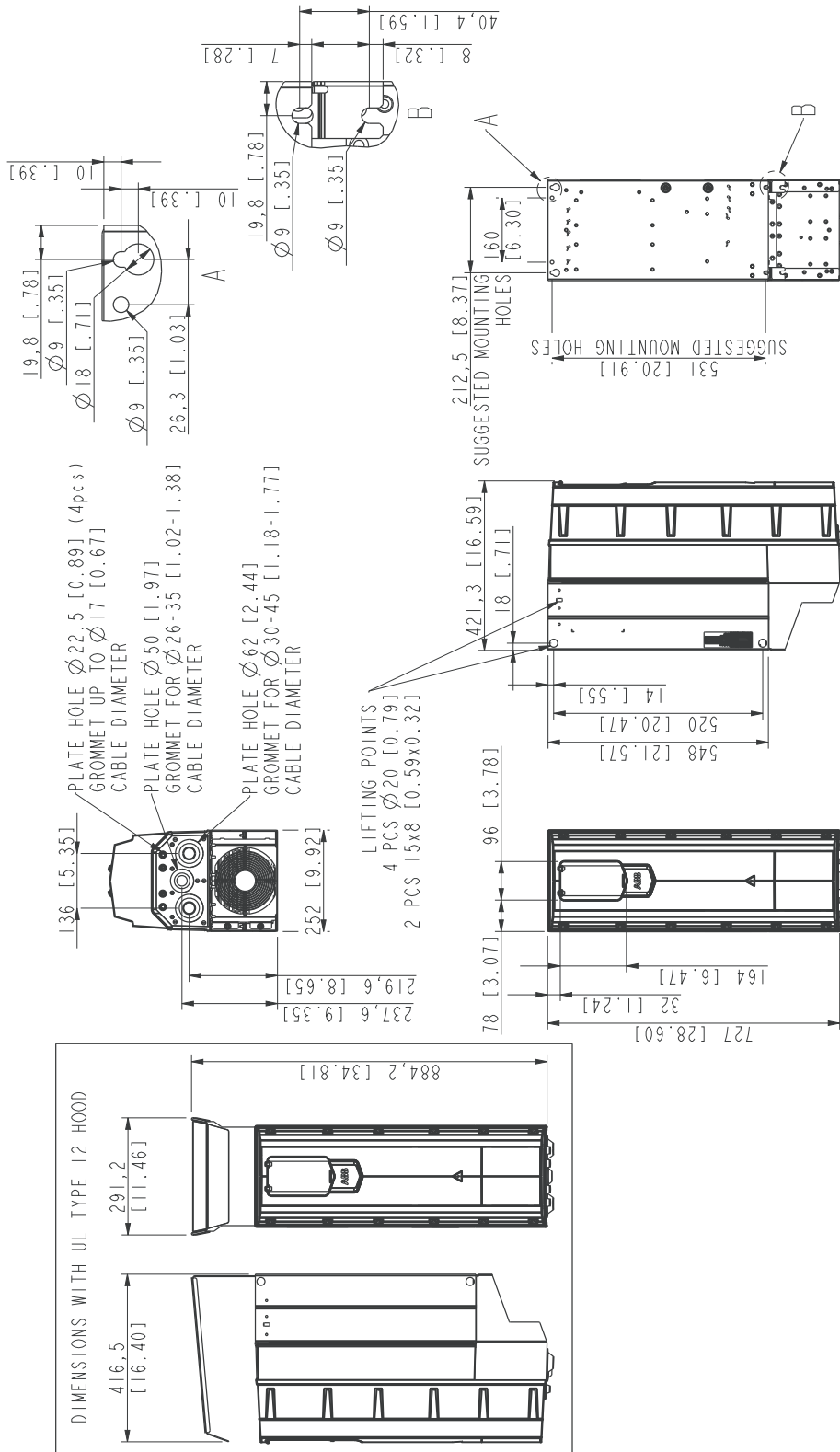

3AUJA0000098321

Frame R7 (IP21, UL Type 1)

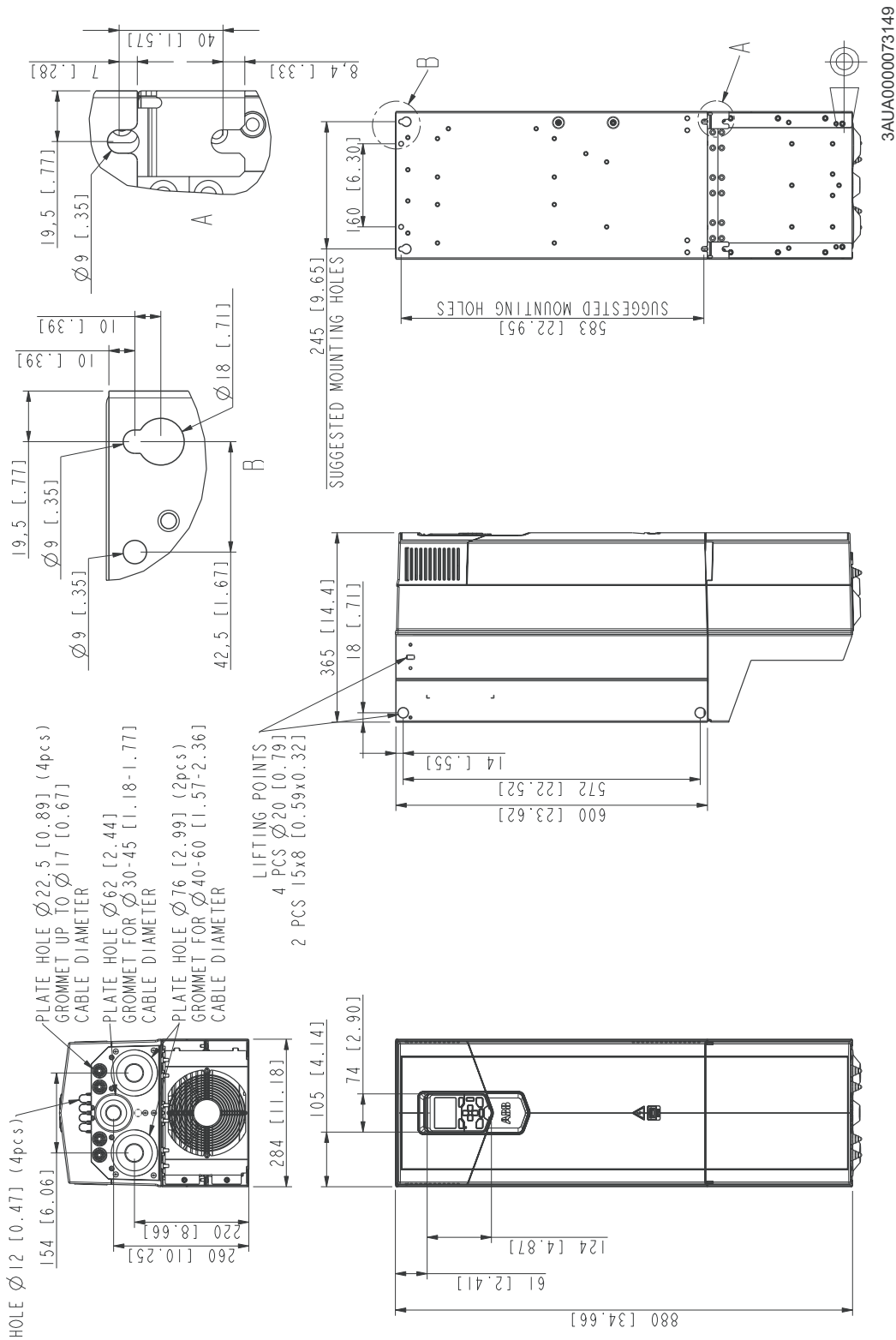

Frame R7 (IP55, UL Type 12)

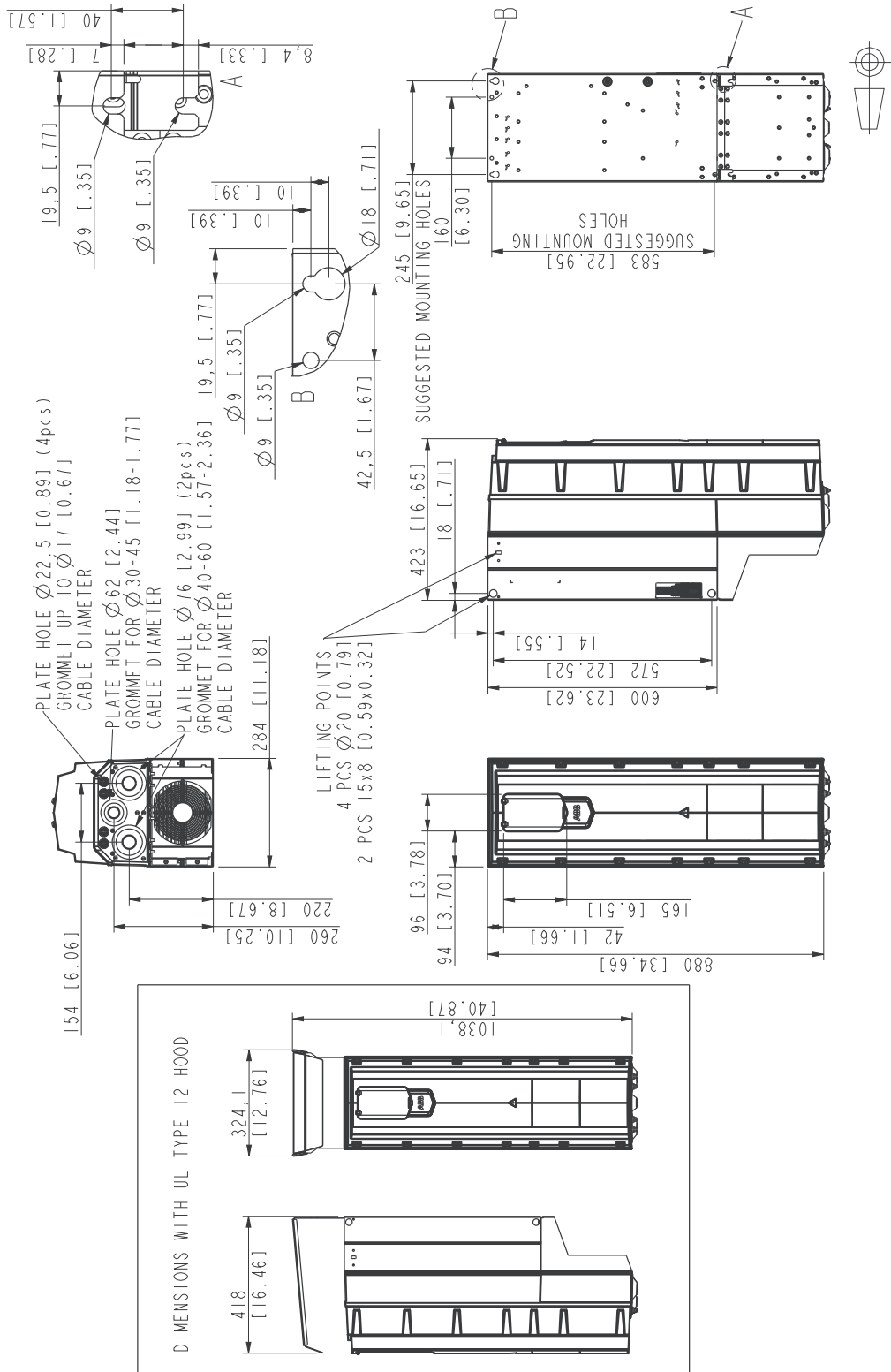

3AUJA0000073149

Frame R8 (IP21, UL Type 1)

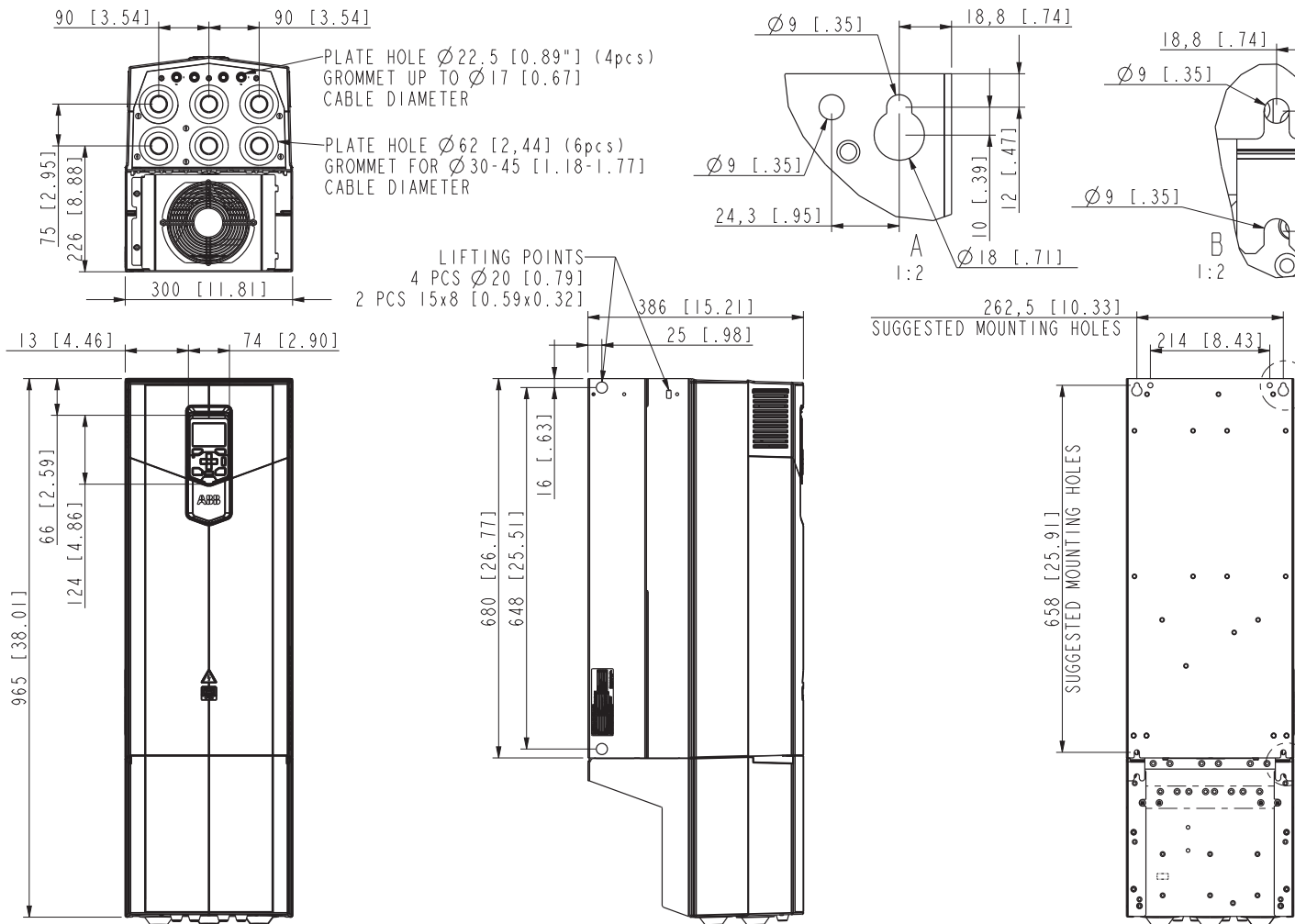

3AUA000007

Frame R8 (IP55, UL Type 12)

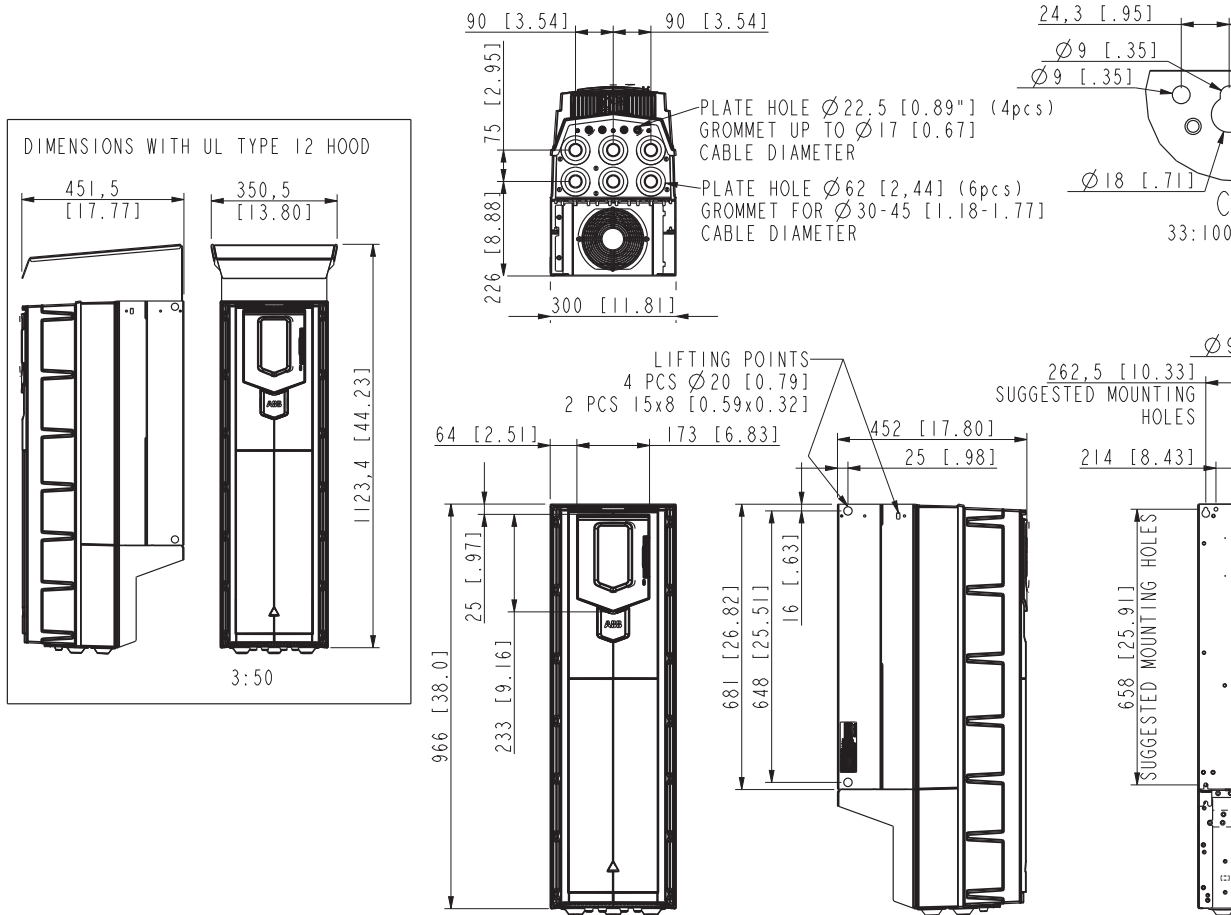

Frame R9 (IP21, UL Type 1)

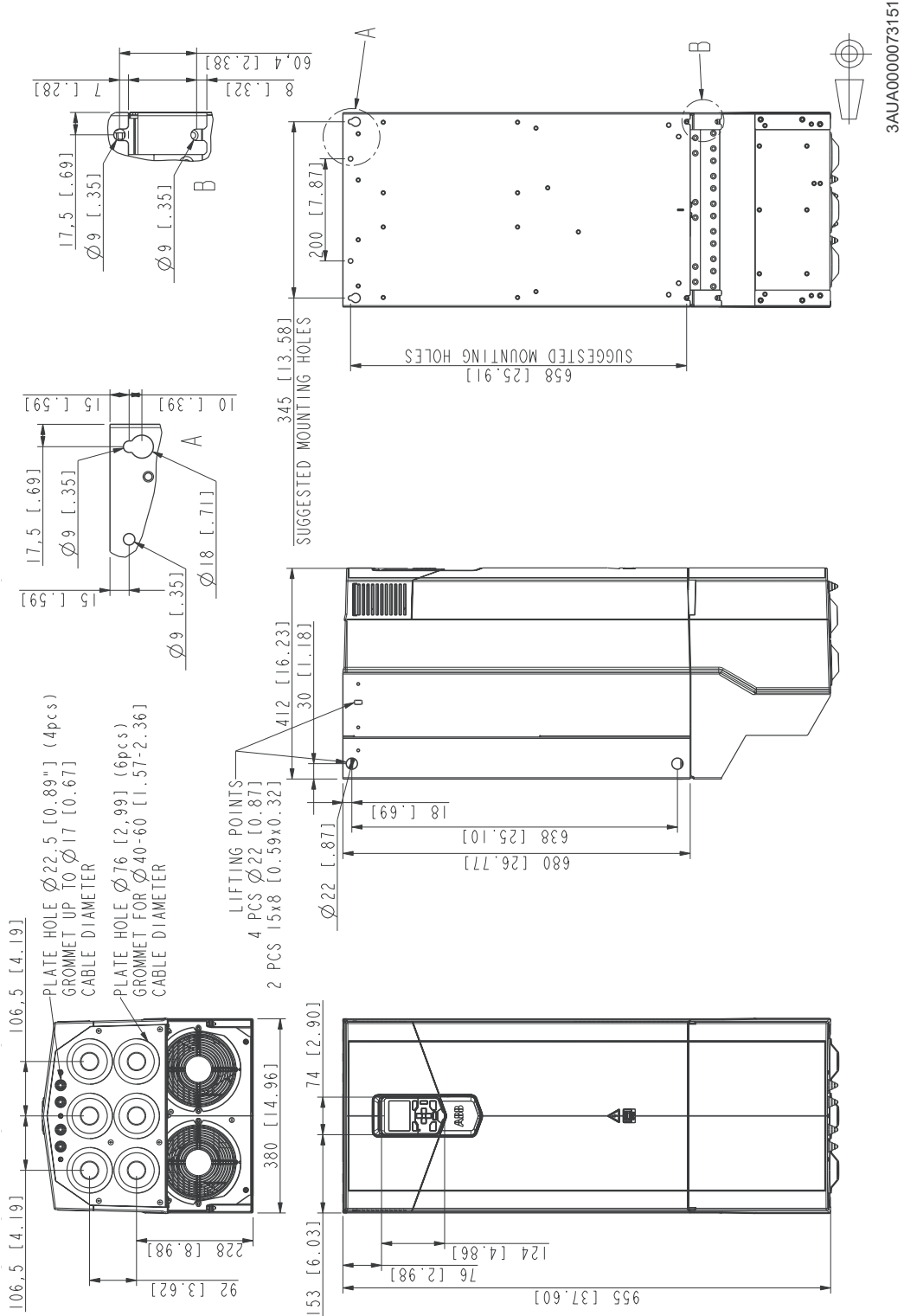

Frame R9 (IP55, UL Type 12)

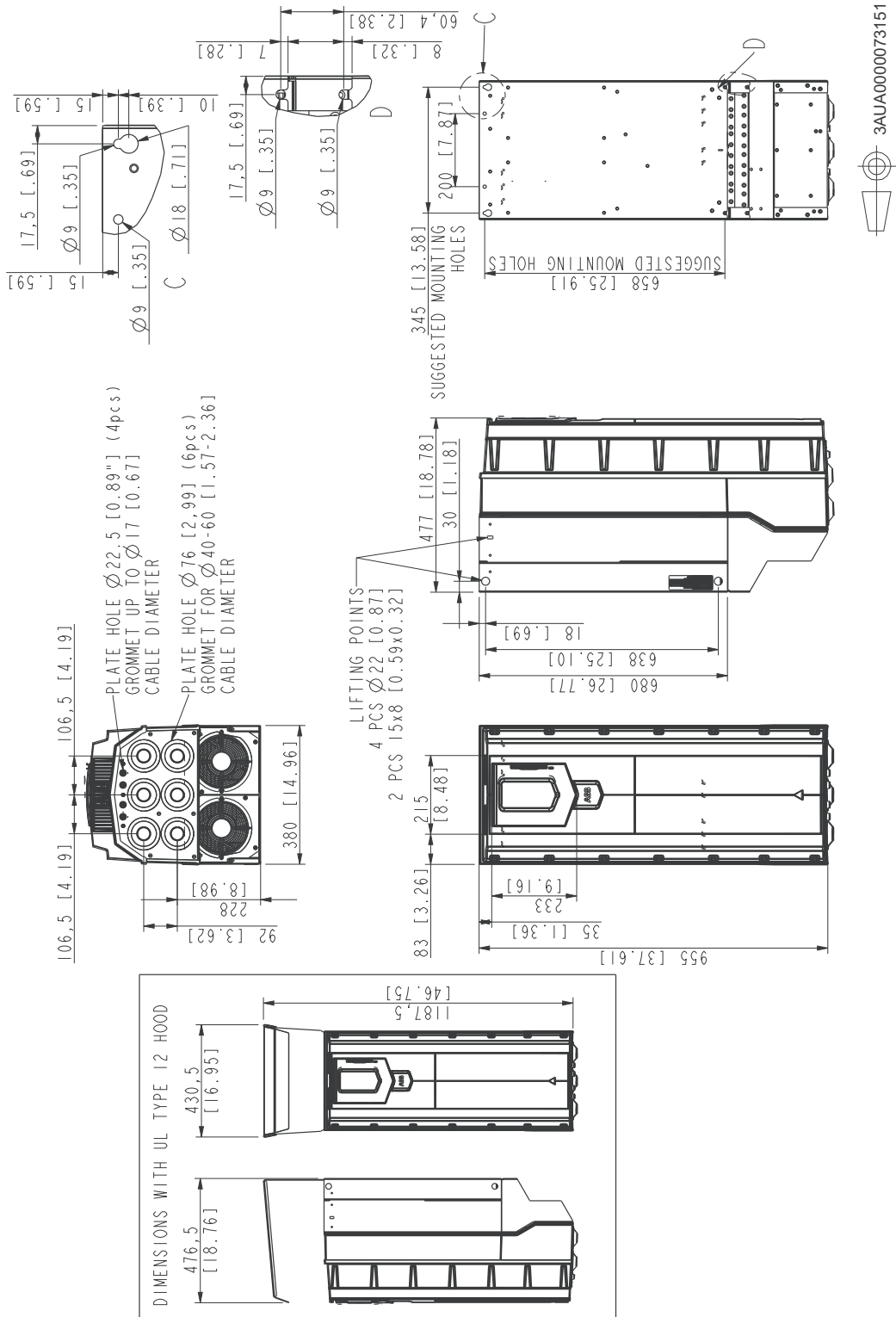

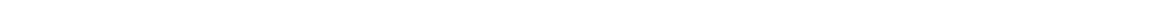

15

Resistor braking

Contents of this chapter

This chapter describes how to select, protect and wire brake choppers and resistors. The chapter also contains technical data

Operation principle and hardware description

Frames R1 to R4 have a built-in brake chopper as standard. Frames R5 and up can be equipped with optional built-in brake chopper (+D150). Brake resistors are available as add-on kits.

The brake chopper handles the energy generated by a decelerating motor. The extra energy increases the DC link voltage. The chopper connects the brake resistor to the intermediate DC circuit whenever the voltage in the circuit exceeds the limit defined by the control program. Energy consumption by the resistor losses lowers the voltage until the resistor can be disconnected.

Planning the braking system

■ Selecting the brake circuit components

1. Calculate the maximum power generated by the motor during braking (P_{\max}).
 2. Select a suitable drive, brake chopper and brake resistor combination for the application from the rating table in this chapter. The braking power of the chopper must be greater or equal than the maximum power generated by the motor during the braking.
 3. Check the resistor selection. The energy generated by the motor during a 400-second period must not exceed the resistor heat dissipation capacity E_R .
-

Note: If the E_R value is not sufficient, it is possible to use a four-resistor assembly in which two standard resistors are connected in parallel, two in series. The E_R value of the four-resistor assembly is four times the value specified for the standard resistor.

■ **Selecting a custom resistor**

If you use a resistor other than the default resistor,

1. make sure that the resistance of the custom resistor is greater or equal than the resistance of the default resistor in the rating table:

$R \geq R_{min}$	
R	Resistance of the custom resistor  WARNING! Never use a brake resistor with a resistance smaller than R_{min} . The drive and the chopper are not able to handle the overcurrent caused by the low resistance.
R_{min}	Resistance of the default resistor

2. make sure that the load capacity of the custom resistor is greater than the instantaneous maximum power consumption of the resistor when it is connected to the drive DC link voltage by the chopper:

$P_r < (U_{DC}^2)/R$															
P_r	Load capacity of the custom resistor  WARNING! Never use a brake resistor with a resistance smaller than R_{min} . The drive and the chopper are not able to handle the overcurrent caused by the low resistance.														
U_{DC}	Drive DC link voltage during braking														
	<table border="1"> <tr> <td>Supply voltage range (V AC)</td> <td>208...240</td> <td>380...415</td> <td>440...480</td> <td>500</td> <td>525...600</td> <td>660...690</td> </tr> <tr> <td>Drive DC link voltage during braking (V DC) when internal brake chopper at 100% pulse width</td> <td>403</td> <td>697</td> <td>806</td> <td>806</td> <td>1008</td> <td>1159</td> </tr> </table>	Supply voltage range (V AC)	208...240	380...415	440...480	500	525...600	660...690	Drive DC link voltage during braking (V DC) when internal brake chopper at 100% pulse width	403	697	806	806	1008	1159
	Supply voltage range (V AC)	208...240	380...415	440...480	500	525...600	660...690								
Drive DC link voltage during braking (V DC) when internal brake chopper at 100% pulse width	403	697	806	806	1008	1159									
See <i>ACS880 primary control program Firmware manual</i> (3AUA0000085967 [English]) for more information.															
R	Resistance of the custom resistor														

■ **Selecting and routing the brake resistor cables**

Use the same cable type for the resistor cabling as for the drive input cabling to ensure that the input fuses also protect the resistor cable. Alternatively, a two conductor shielded cable with the same cross-sectional area can be used.

Minimizing electromagnetic interference

Follow these rules in order to minimize electromagnetic interference caused by the rapid current changes in the resistor cables:

- Shield the braking power line completely, either by using shielded cable or a metallic enclosure. Unshielded single-core cable can only be used if it is routed inside a cabinet that efficiently suppresses the radiated emissions.
- Install the cables away from other cable routes.
- Avoid long parallel runs with other cables. The minimum parallel cabling separation distance should be 0.3 meters.
- Cross the other cables at right angles.
- Keep the cable as short as possible in order to minimize the radiated emissions and stress on chopper IGBTs. The longer the cable the higher the radiated emissions, inductive load and voltage peaks over the IGBT semiconductors of the brake chopper.

■ **Maximum cable length**

The maximum length of the resistor cable(s) is 10 m (33 ft).

■ **EMC compliance of the complete installation**

ABB has not verified that the EMC requirements are fulfilled with external user-defined brake resistors and cabling. The EMC compliance of the complete installation must be considered by the customer.

■ **Placing the brake resistors**

Install the resistors outside the drive in a place where they will cool.

Arrange the cooling of the resistor in a way that:

- no danger of overheating is caused to the resistor or nearby materials
- the temperature of the room the resistor is located in does not exceed the allowed maximum.

Supply the resistor with cooling air/water according to the resistor manufacturer's instructions.



WARNING! The materials near the brake resistor must be non-flammable. The surface temperature of the resistor is high. Air flowing from the resistor is of hundreds of degrees Celsius. If the exhaust vents are connected to a ventilation system, ensure that the material withstands high temperatures. Protect the resistor against contact.

■ **Protecting the system against thermal overload**

The brake chopper protects itself and the resistor cables against thermal overload when the cables are dimensioned according to the nominal current of the drive. The drive control program includes a resistor and resistor cable thermal protection function which can be tuned by the user. See the firmware manual.

Frames R1 to R4

Equipping the drive with a main contactor is highly recommended for safety reasons. Wire the contactor so that it opens in case the resistor overheats. This is essential for safety since the drive will not otherwise be able to interrupt the main supply if the chopper remains conductive in a fault situation. An example wiring diagram is shown below. ABB resistors are equipped with a thermal switch (1) inside the resistor assembly as standard. The switch indicates overtemperature and overload.

ABB recommends that you also wire the thermal switch to a digital input of the drive

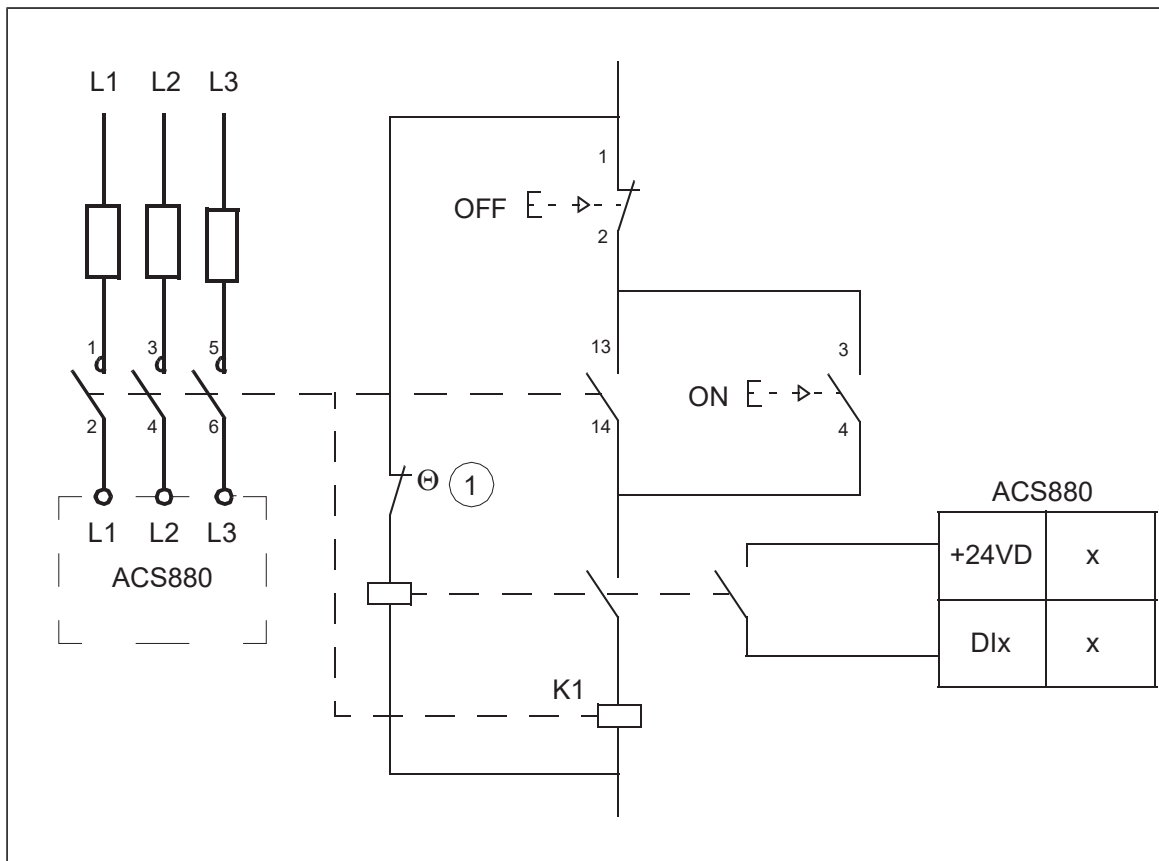

Frames R5 to R9

A main contactor is not required for protecting against resistor overheating when the resistor is dimensioned according to the instructions and the internal brake chopper is in use. The drive will disable power flow through the input bridge if the chopper remains conductive in a fault situation but the charging resistor may fail.

Note: If an external brake chopper (outside the drive module) is used, a main contactor is always required.

A thermal switch (standard in ABB resistors) is required for safety reasons. The thermal switch cable must be shielded and may not be longer than the resistor cable. Wire the switch to a digital input on the drive control unit as shown in the figure below.

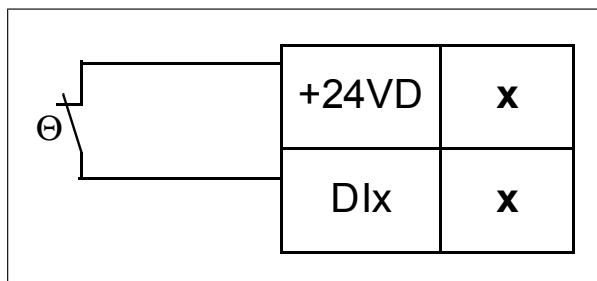

Protecting the resistor cable against short-circuits

The input fuses will also protect the resistor cable when it is identical with the input cable.

Mechanical installation

Brake resistors must be installed outside the drive. Obey the resistor manufacturer's instructions.

Electrical installation

■ Measuring the insulation of the assembly

See section *Measuring the insulation of the brake resistor circuit (page 85)*

■ Connection diagram

See section *Connection diagram (page 86)*.

■ Connection procedure

- Connect the resistor cables to the R+ and R- terminals in the same way as the other power cables. If a shielded three-conductor cable is used, cut the third conductor, insulate it, and ground the twisted shield of the cable (protective earth conductor of the resistor assembly) at both ends.
- Connect the thermal switch of the brake resistor as described above in section *Frames R1 to R4* or *Frames R5 to R9*.

Start-up

Note: Protective oil on the brake resistors will burn off when the brake resistor is used for the first time. Make sure that the airflow is sufficient.

Set the following parameters (ACS880 primary control program):

- Disable the overvoltage control of the drive by parameter *30.30 Overvoltage control*.
- Set parameter *31.01 External event 1 source* to point to the digital input where the thermal switch of the brake resistor is wired.
- Set parameter *31.02 External event 1 type* to *Fault*.
- Enable the brake chopper by parameter *43.06 Brake chopper enable*. If Enabled with thermal model is selected, set also the brake resistor overload protection parameters *43.08* and *43.09* according to the application.
- For frames R5 to R9: Set parameter *43.07 Brake chopper runtime enable* to *Other [bit]* and select from parameter *10.01 DI status* the digital input where the thermal switch of the brake resistor is wired.
- Check the resistance value of parameter *43.10 Brake resistance*.

With these parameter settings, the drive stops by coasting on brake resistor overtemperature.



WARNING! If the drive is equipped with a brake chopper but the chopper is not enabled by the parameter setting, the internal thermal protection of the drive against resistor overheating is not in use. In this case, the brake resistor must be disconnected.

For settings of other control programs, see the appropriate firmware manual.

Technical data

■ Ratings

ACS880-01-...	Internal brake chopper		Example brake resistor(s)			
	P_{brcont}	R_{min}	Type	R	E_R	P_{Rcont}
	kW	ohm		ohm	kJ	kW
$U_N = 230\text{ V}$						
04A6-2	0.75	65	JBR-03	80	40	0.14
06A6-2	1.1	65	JBR-03	80	40	0.14
07A5-2	1.5	65	JBR-03	80	40	0.14
10A6-2	2.2	65	JBR-03	80	40	0.14
16A8-2	4.0	18	SACE15RE22	22	420	2
24A3-2	5.5	18	SACE15RE22	22	420	2
031A-2	7.5	13	SACE15RE13	13	435	2
046A-2	11	12	SACE15RE13	13	435	2
061A-2	11	12	SACE15RE13	13	435	2
075A-2	18.5	6	SAFUR90F575	8	1800	4.5
087A-2	22	6	SAFUR90F575	8	1800	4.5
115A-2	30	3.5	SAFUR125F500	4	3600	9
145A-2	37	3.5	SAFUR125F500	4	3600	9
170A-2	45	2.4	SAFUR200F500	2.7	5400	13.5
206A-2	55	2.4	SAFUR200F500	2.7	5400	13.5
274A-2	75	1.8	SAFUR200F500	2.7	5400	13.5
$U_N = 400\text{ V}$						
02A4-3	0.75	78	JBR-03	80	40	0.14
03A3-3	1.1	78	JBR-03	80	40	0.14
04A0-3	1.5	78	JBR-03	80	40	0.14
05A6-3	2.2	78	JBR-03	80	40	0.14
07A2-3	3.0	78	JBR-03	80	40	0.14
09A4-3	4.0	78	JBR-03	80	40	0.14
12A6-3	5.5	78	JBR-03	80	40	0.14
017A-3	7.5	39	SACE08RE44	44	210	1
025A-3	11	39	SACE08RE44	44	210	1
032A-3	15	19	SACE15RE22	22	420	2
038A-3	18.5	19	SACE15RE22	22	420	2
045A-3	22	13	SACE15RE13	13	435	2
061A-3	22	13	SACE15RE13	13	435	2
072A-3	37	8	SAFUR90F575	8	1800	4.5
087A-3	45	8	SAFUR90F575	8	1800	4.5
105A-3	55	5.4	SAFUR80F500	6	2400	6
145A-3	75	5.4	SAFUR80F500	6	2400	6
169A-3	90	3.3	SAFUR125F500	4	3600	9

ACS880-01-...	Internal brake chopper		Example brake resistor(s)			
	P_{brcont}	R_{min}	Type	R	E_R	P_{Rcont}
	kW	ohm		ohm	kJ	kW
206A-3	110	3.3	SAFUR125F500	4	3600	9
246A-3	132	2.3	SAFUR200F500	2.7	5400	13.5
293A-3	132	2.3	SAFUR200F500	2.7	5400	13.5
363A-3	160	2.0	SAFUR200F500	2.7	5400	13.5
430A-3	160	2.0	SAFUR200F500	2.7	5400	13.5
$U_N = 500 \text{ V}$						
02A1-5	0.75	78	JBR-03	80	40	0.14
03A0-5	1.1	78	JBR-03	80	40	0.14
03A4-5	1.5	78	JBR-03	80	40	0.14
04A8-5	2.2	78	JBR-03	80	40	0.14
05A2-5	3.0	78	JBR-03	80	40	0.14
07A6-5	4.0	78	JBR-03	80	40	0.14
11A0-5	5.5	78	JBR-03	80	40	0.14
014A-5	7.5	39	SACE08RE44	44	210	1
021A-5	11	39	SACE08RE44	44	210	1
027A-5	15	19	SACE15RE22	22	420	2
034A-5	18.5	19	SACE15RE22	22	420	2
040A-5	22	13	SACE15RE13	13	435	2
052A-5	22	13	SACE15RE13	13	435	2
065A-5	37	8	SAFUR90F575	8	1800	4.5
077A-5	45	8	SAFUR90F575	8	1800	4.5
096A-5	55	5.4	SAFUR80F500	6	2400	6
124A-5	75	5.4	SAFUR80F500	6	2400	6
156A-5	90	3.3	SAFUR125F500	4	3600	9
180A-5	110	3.3	SAFUR125F500	4	3600	9
240A-5	132	2.3	SAFUR200F500	2.7	5400	13.5
260A-5	132	2.3	SAFUR200F500	2.7	5400	13.5
302A-5	160	2.3	SAFUR200F500	2.7	5400	13.5
361A-5	160	2.3	SAFUR200F500	2.7	5400	13.5
414A-5	160	2.3	SAFUR200F500	2.7	5400	13.5
$U_N = 690 \text{ V}$						
07A4-7	5.5	44	SACE08RE44	44	210	1
09A9-7	7.5	44	SACE08RE44	44	210	1
14A3-7	11.0	44	SACE08RE44	44	210	1
019A-7	15.0	44	SACE08RE44	44	210	1
023A-7	18.5	44	SACE08RE44	44	210	1
027A-7	22.0	44	SACE08RE44	44	210	1
07A3-7	6	18	SACE08RE44	44	210	1
09A8-7	8	18	SACE08RE44	44	210	1
14A2-7	11	18	SACE08RE44	44	210	1

ACS880-01-...	Internal brake chopper		Example brake resistor(s)			
	P_{brcont}	R_{min}	Type	R	E_R	P_{Rcont}
]kW	ohm		ohm	kJ	kW
018A-7	17	18	SACE15RE22	22	420	2
022A-7	23	18	SACE15RE22	22	420	2
026A-7	28	18	SACE15RE22	22	420	2
035A-7	33	18	SACE15RE22	22	420	2
042A-7	45	18	SACE15RE22	22	420	2
049A-7	45	18	SACE15RE22	22	420	2
061A-7	55	13	SACE15RE13	13	435	2
084A-7	65	13	SACE15RE13	13	435	2
098A-7	90	8	SAFUR90F575	8	1800	4.5
119A-7	110	8	SAFUR90F575	8	1800	4.5
142A-7	132	6	SAFUR80F500	6	2400	6
174A-7	160	6	SAFUR80F500	6	2400	6
210A-7	200	4	SAFUR125F500	4	3600	9
271A-7	250	4	SAFUR125F500	4	3600	9

P_{brcont} Maximum continuous braking power. The braking is considered continuous if the braking time exceeds 30 seconds.

R_{min} Minimum allowed resistance value of the brake resistor

R Resistance value for the listed resistor assembly

E_R Short energy pulse that the resistor assembly withstands every 400 seconds

P_{Rcont} Continuous power (heat) dissipation of the resistor when placed correctly

■ Degree of protection and thermal constant of the resistor

Resistor type	Degree of protection	Thermal constant (s)
JBR-03	IP20	
SACE	IP21	200
SAFUR	IP00	555

Dimensions and weights of external resistors

■ JBR-03

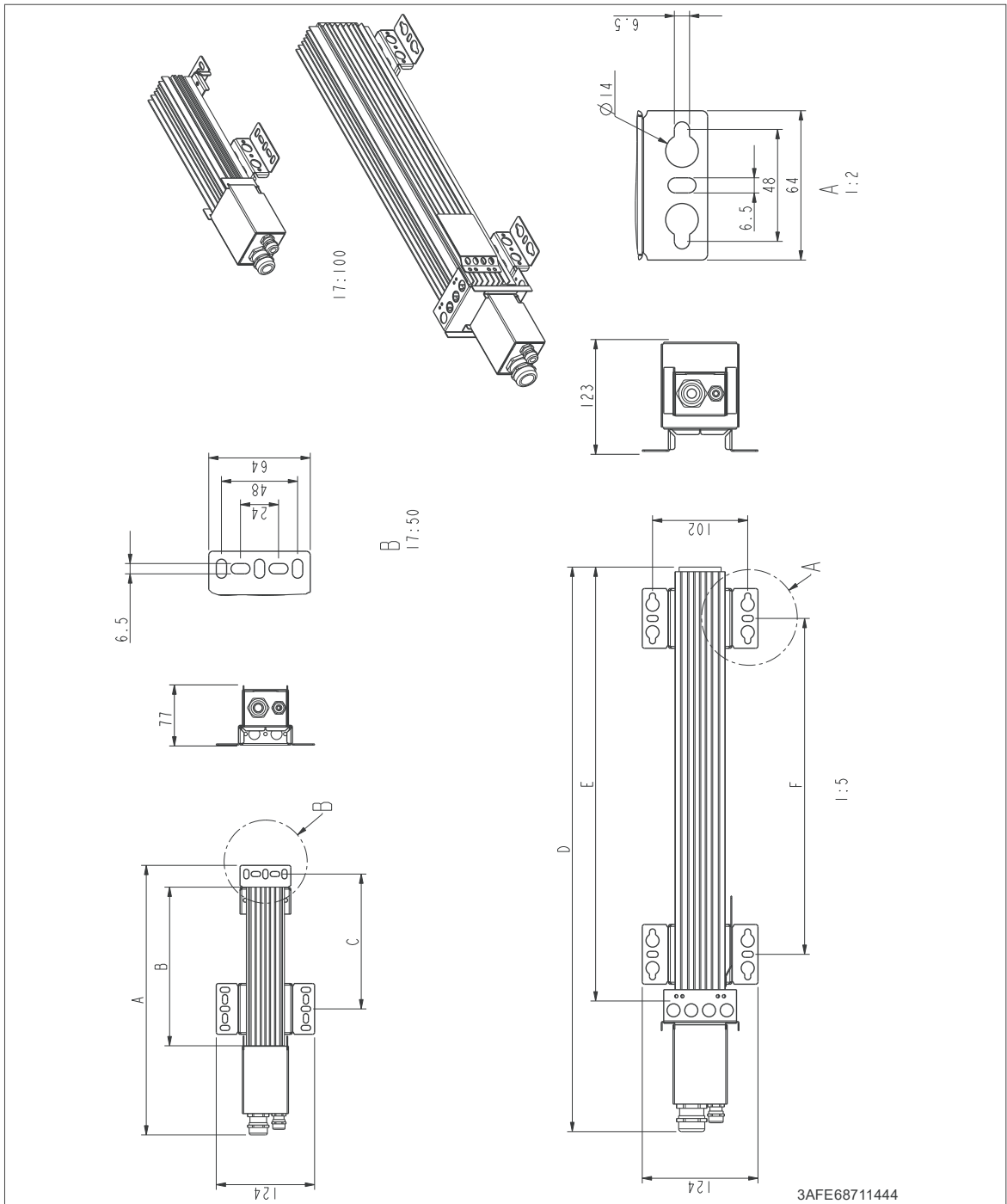

JBR-03 brake resistor	
Dimension A	340 mm (13.39 in)
Dimension B	200 mm (7.87 in)
Dimension C	170 mm (6.69 in)
Weight	0.8 kg (1.8 lb)

254 Resistor braking

JBR-03 brake resistor	
Maximum wire size of main terminals	10 mm ² (AWG6)
Tightening torque of main terminals	1.5 ... 1.8 N·m (13 ... 16 lbf-in)
Wire size of thermal switch terminals	4 mm ² (AWG12)
Tightening torque of thermal switch terminals	0.6 ... 0.8 N·m (5.3 ... 7.1 lbf-in)

■ **SACE08RE44**

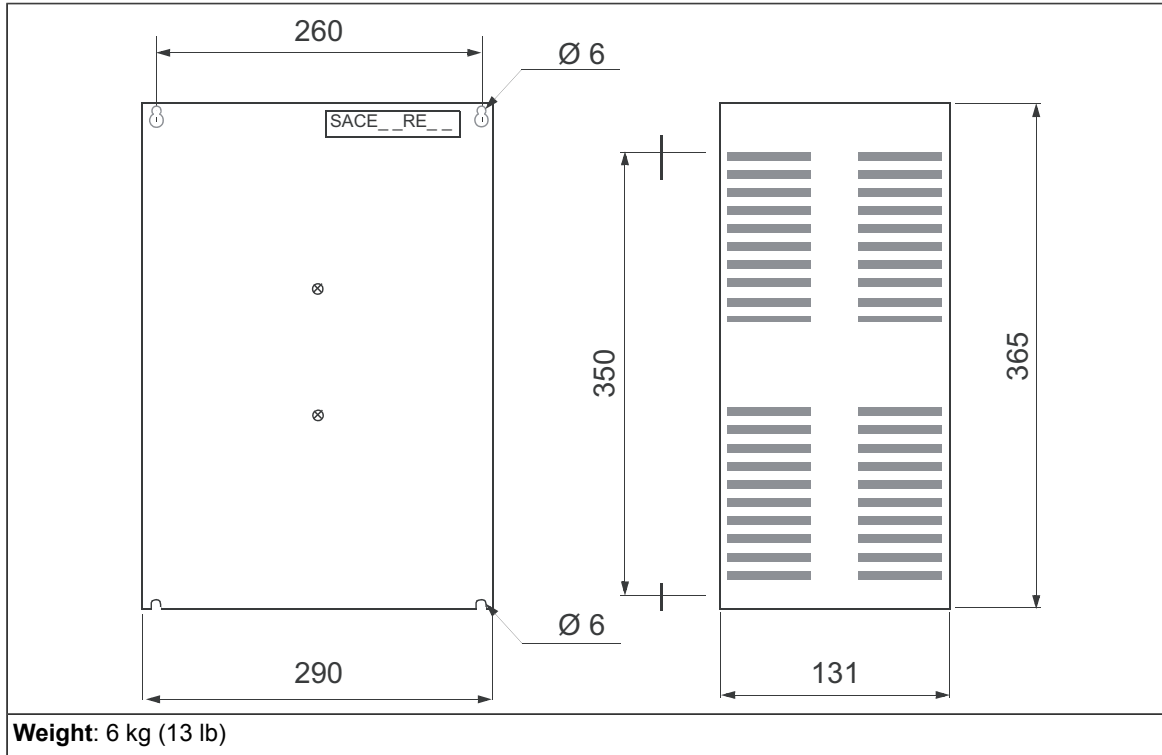

■ **SACE15RE13 and SACE15RE2**

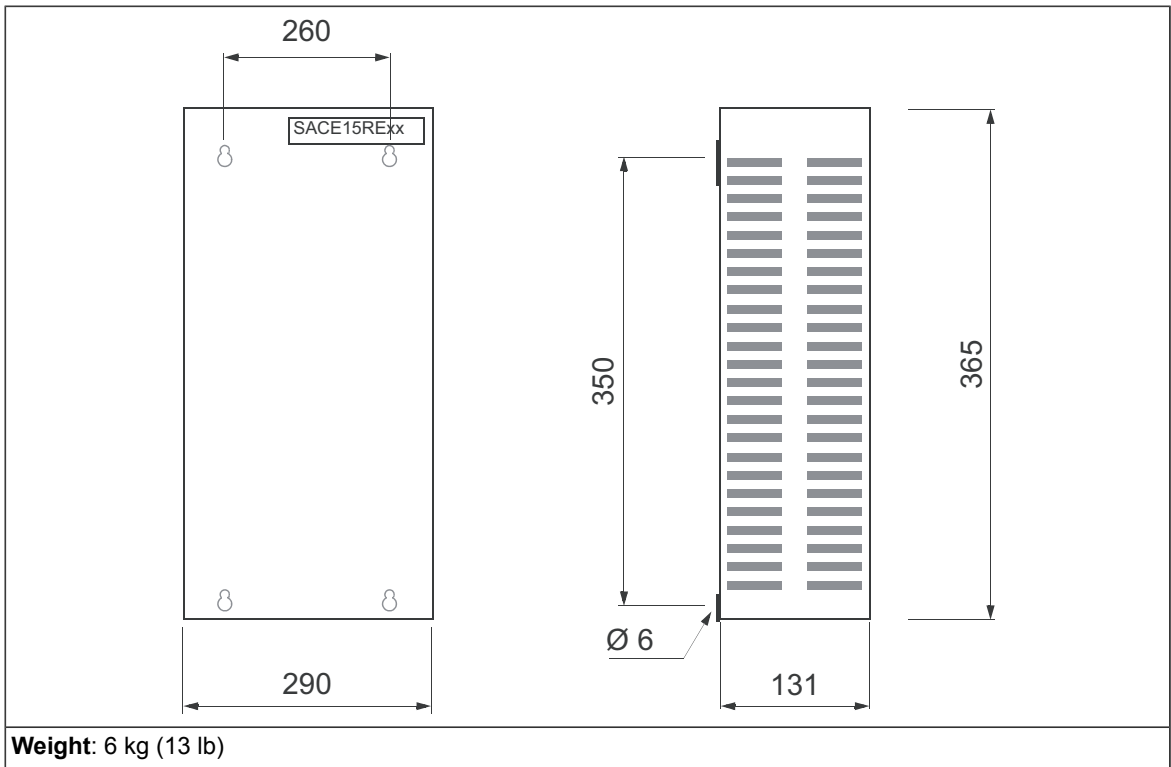

■ **SAFUR80F500 and SAFUR90F575**

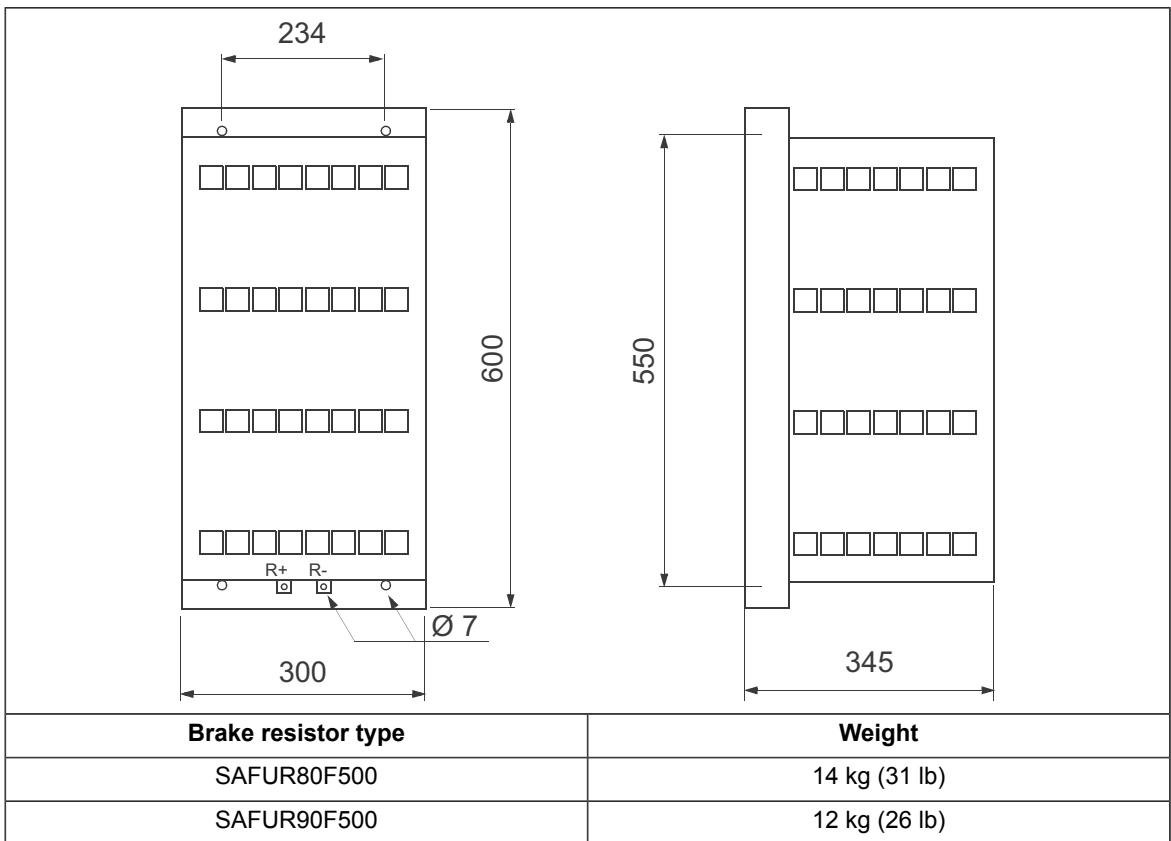

■ SAFUR125F500 and SAFUR200F500

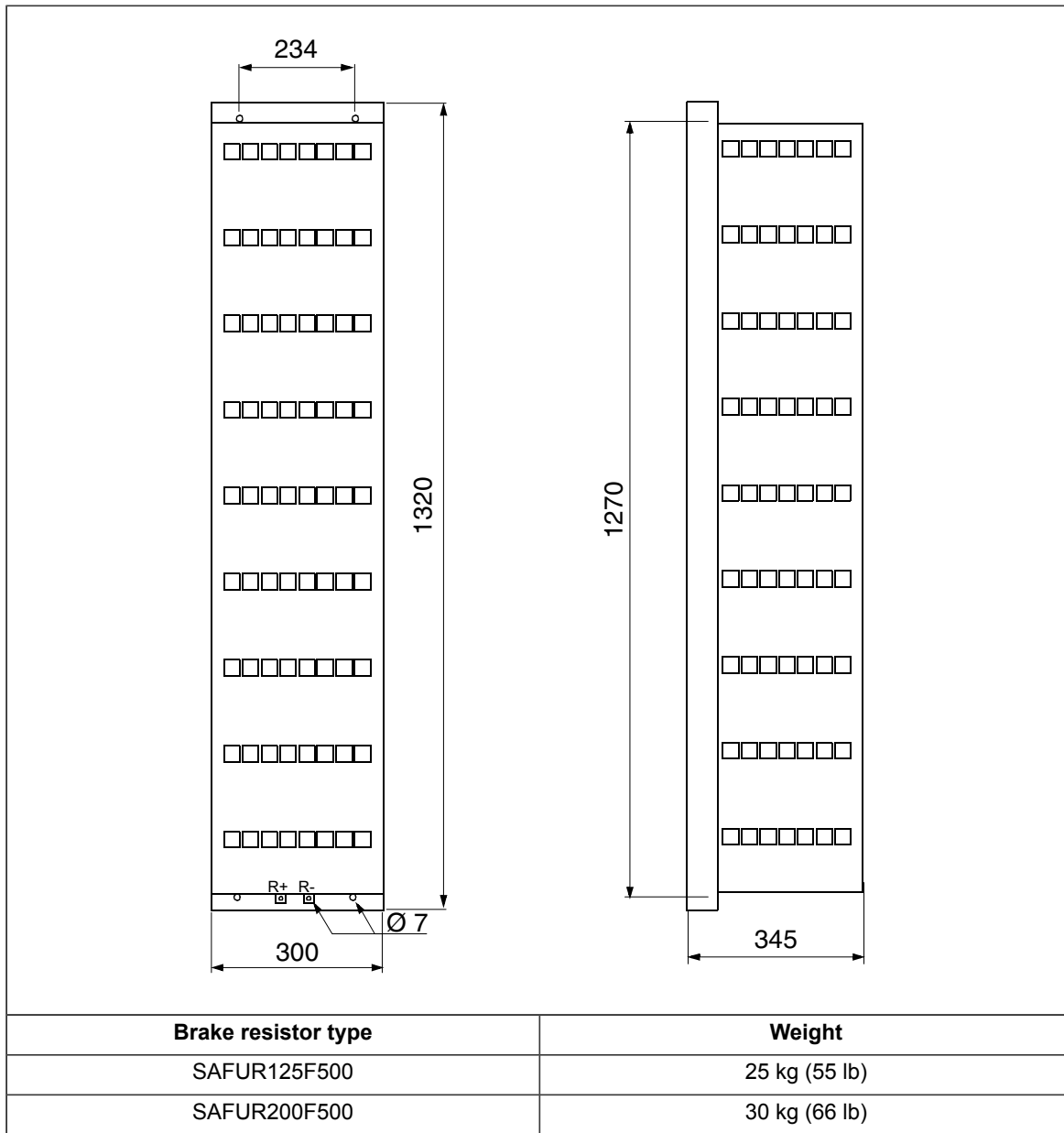

16

The Safe torque off function

Contents of this chapter

This chapter describes the Safe torque off (STO) function of the drive and gives instructions for its use.

Description



WARNING!

In case of parallel-connected drives or dual-winding motors, the STO must be activated on each drive to remove the torque from the motor.

The Safe torque off function can be used, for example, as the final actuator device of safety circuits that stop the drive in case of danger (such as an emergency stop circuit). Another typical application is a prevention of unexpected start-up function that enables short-time maintenance operations like cleaning or work on non-electrical parts of the machinery without switching off the power supply to the drive.

When activated, the Safe torque off function disables the control voltage of the power semiconductors of the drive output stage (A, see the diagrams below), thus preventing the drive from generating the torque required to rotate the motor. If the motor is running when Safe torque off is activated, it coasts to a stop.

The Safe torque off function has a redundant architecture, that is, both channels must be used in the safety function implementation. The safety data given in this manual is calculated for redundant use, and does not apply if both channels are not used.

The Safe torque off function complies with these standards:

Standard	Name
IEC 60204-1:2016 EN 60204-1:2018	<i>Safety of machinery – Electrical equipment of machines – Part 1: General requirements</i>

Standard	Name
IEC 61000-6-7:2014	<i>Electromagnetic compatibility (EMC) – Part 6-7: Generic standards – Immunity requirements for equipment intended to perform functions in a safety-related system (functional safety) in industrial locations</i>
IEC 61326-3-1:2017	<i>Electrical equipment for measurement, control and laboratory use – EMC requirements – Part 3-1: Immunity requirements for safety-related systems and for equipment intended to perform safety-related functions (functional safety) – General industrial applications</i>
IEC 61508-1:2010	<i>Functional safety of electrical/electronic/programmable electronic safety-related systems – Part 1: General requirements</i>
IEC 61508-2:2010	<i>Functional safety of electrical/electronic/programmable electronic safety-related systems – Part 2: Requirements for electrical/electronic/programmable electronic safety-related systems</i>
IEC 61511-1:2016	<i>Functional safety – Safety instrumented systems for the process industry sector</i>
IEC 61800-5-2:2016 EN 61800-5-2:2007	<i>Adjustable speed electrical power drive systems – Part 5-2: Safety requirements – Functional</i>
IEC 62061:2005 + A1:2012 + A2:2015 EN 62061:2005 + AC:2010 + A1:2013 + A2:2015	<i>Safety of machinery – Functional safety of safety-related electrical, electronic and programmable electronic control systems</i>
EN ISO 13849-1:2015	<i>Safety of machinery – Safety-related parts of control systems – Part 1: General principles for design</i>
EN ISO 13849-2:2012	<i>Safety of machinery – Safety-related parts of control systems – Part 2: Validation</i>

The function also corresponds to Prevention of unexpected start-up as specified by EN ISO 14118:2018 (ISO 14118:2017), and Uncontrolled stop (stop category 0) as specified in EN/IEC 60204-1.

■ **Compliance with the European Machinery Directive**

See the technical data.

The Declaration of conformity is shown at the end of this chapter.

Wiring

For the electrical specifications of the STO connection, see the technical data of the control unit.

■ Activation switch

In the wiring diagrams, the activation switch has the designation [K]. This represents a component such as a manually operated switch, an emergency stop push button switch, or the contacts of a safety relay or safety PLC.

- In case a manually operated activation switch is used, the switch must be of a type that can be locked out to the open position.
- The contacts of the switch or relay must open/close within 200 ms of each other.
- An FSO-xx safety functions module or an FPTC-0x thermistor protection module can also be used. For more information, see the module documentation.

■ Cable types and lengths

- Double-shielded twisted-pair cable is recommended.
- Maximum cable lengths:
 - 300 m (1000 ft) between activation switch [K] and drive control unit
 - 60 m (200 ft) between multiple drives
 - 60 m (200 ft) between external power supply and first control unit

Note: A short-circuit in the wiring between the switch and an STO terminal causes a dangerous fault. Therefore, it is recommended to use a safety relay (including wiring diagnostics) or a wiring method (shield grounding, channel separation) which reduces or eliminates the risk caused by the short-circuit.

Note: The voltage at the STO input terminals of the control unit must be at least 17 V DC to be interpreted as “1”.

The pulse tolerance of the input channels is 1 ms.

■ Grounding of protective shields

- Ground the shield in the cabling between the activation switch and the control unit at the control unit only.
 - Ground the shield in the cabling between two control units at one control unit only.
-

■ Single drive (internal power supply)

Dual-channel connection

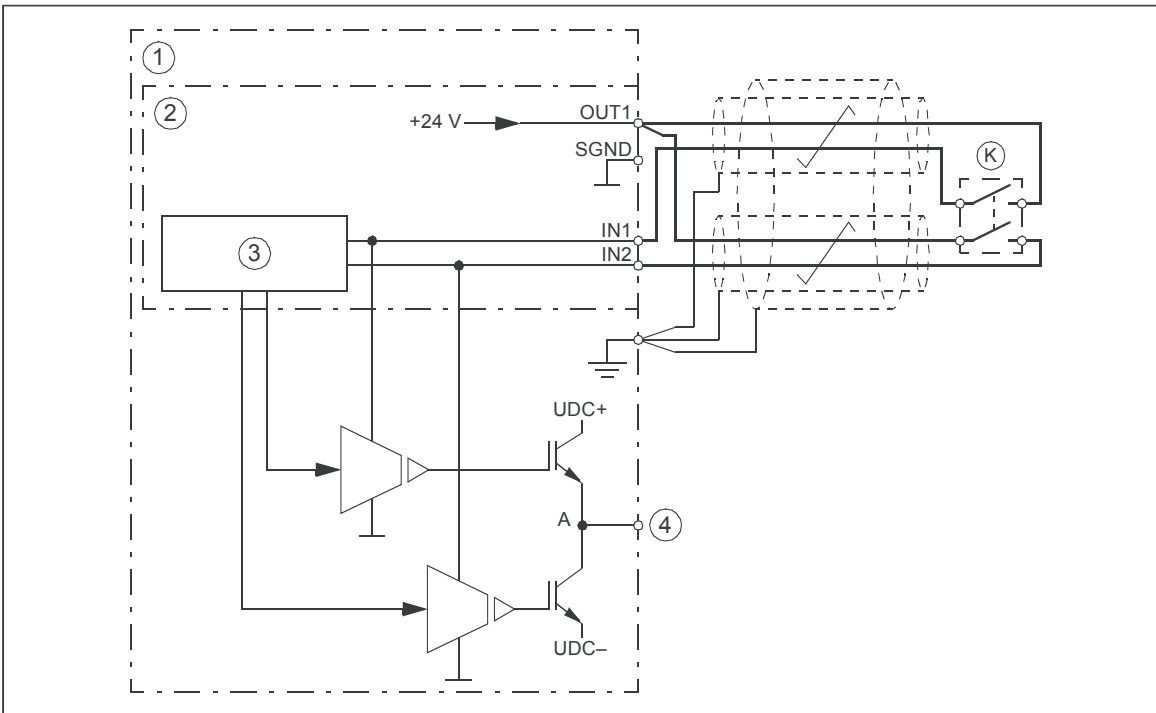

1	Drive
2	Control unit
3	Control logic
4	To motor
K	Activation switch

Single-channel connection

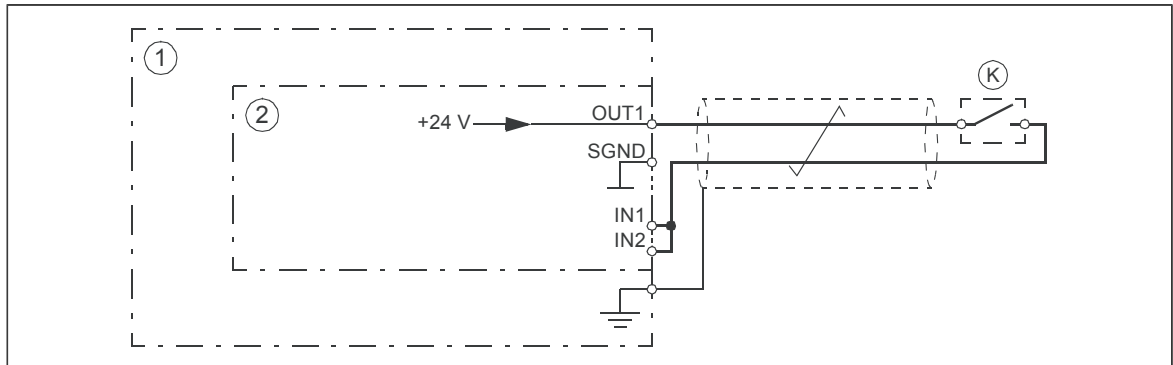

Note:

- Both STO inputs (IN1, IN2) must be connected to the activation switch. Otherwise, no SIL/PL classification is given.
- Pay special attention to avoiding any potential failure modes for the wiring. For example, use shielded cable. For measures for fault exclusion of wiring, see eg. EN ISO 13849-2:2012, table D.4.

1	Drive
2	Control unit
K	Activation switch

■ Multiple drives

Internal power supply

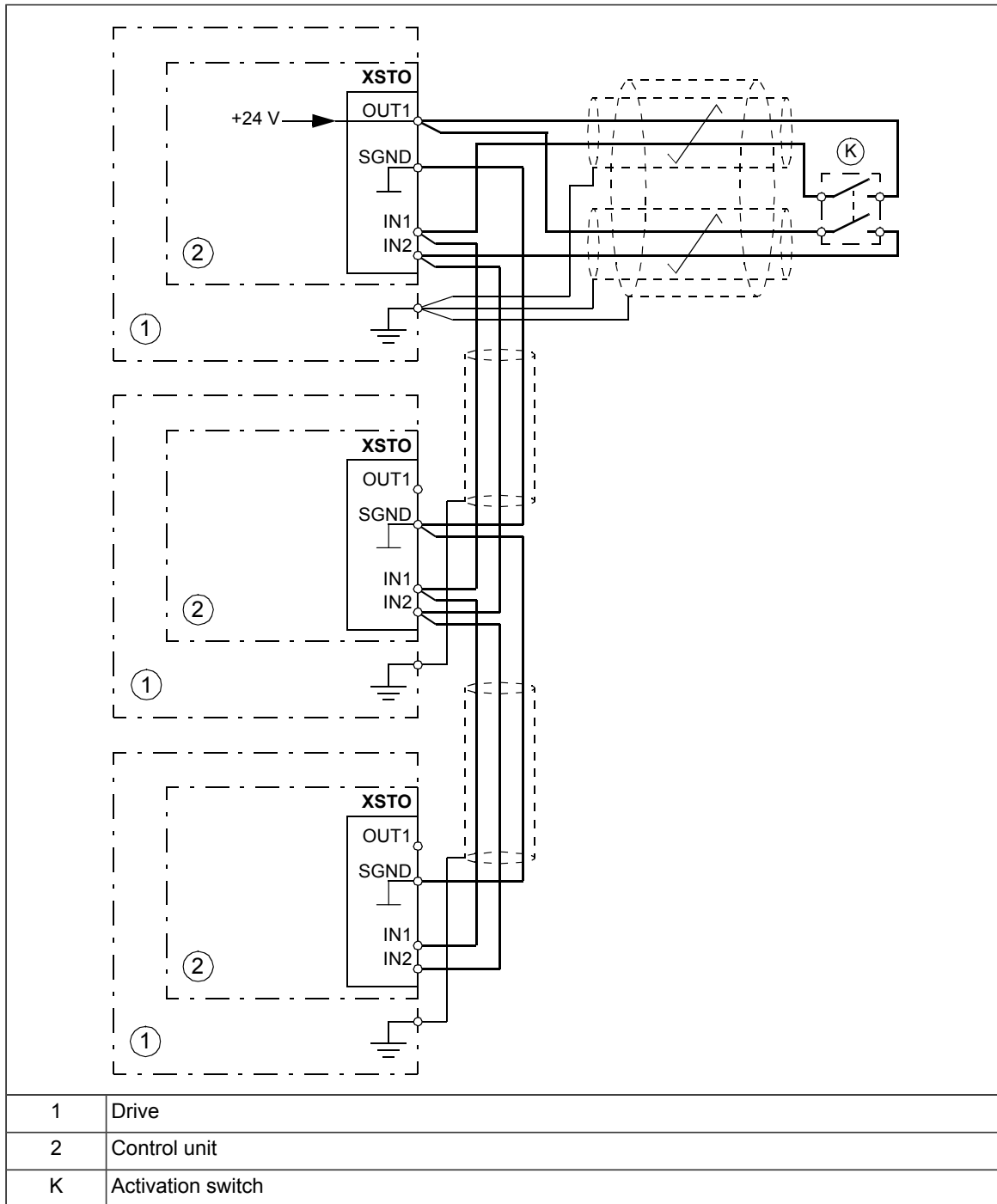

External power supply

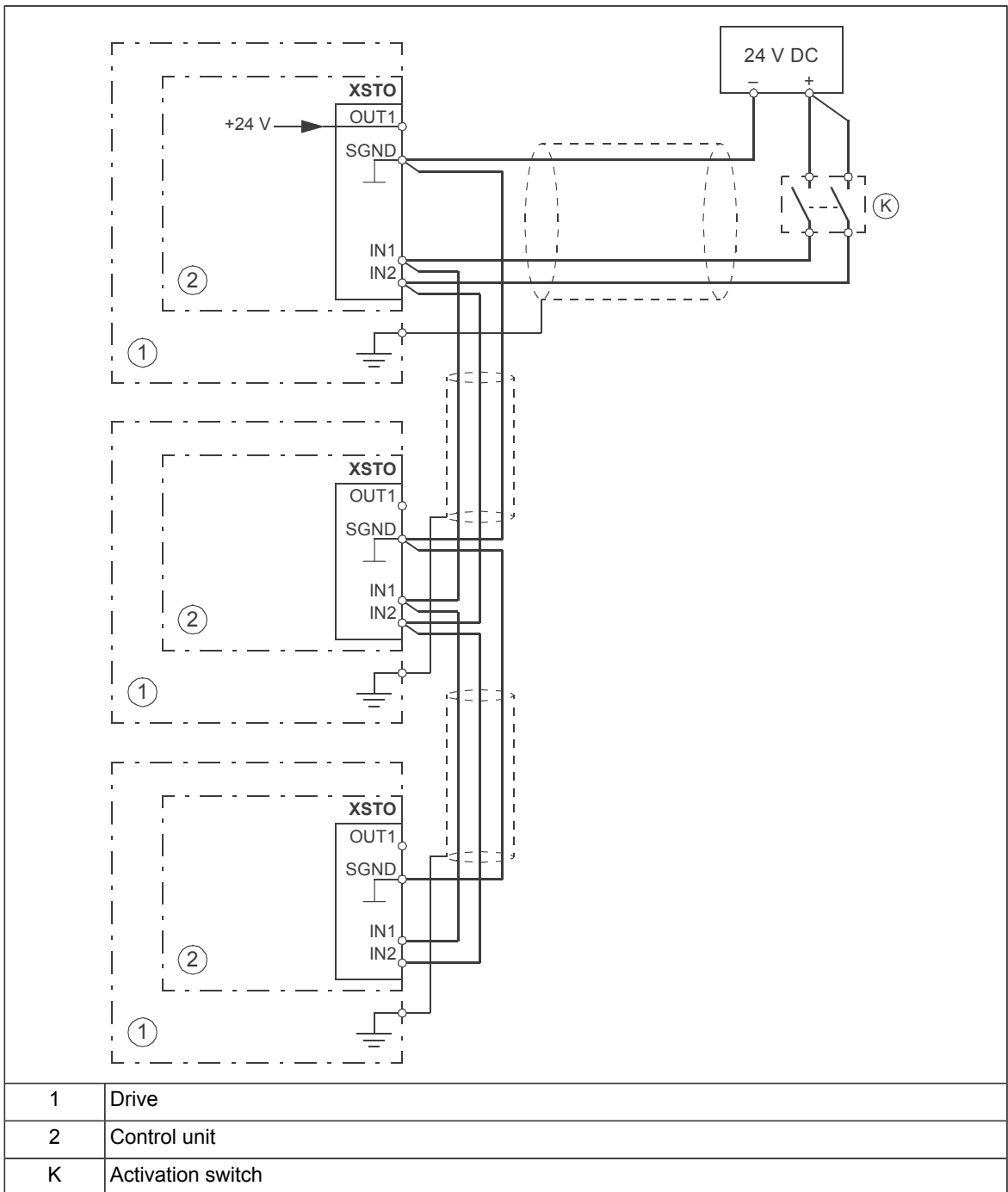

Operation principle

1. The Safe torque off activates (the activation switch is opened, or safety relay contacts open).
2. The STO inputs of the drive control unit de-energize.
3. The control unit cuts off the control voltage from the output IGBTs.
4. The control program generates an indication as defined by parameter 31.22 (see the firmware manual of the drive).

The parameter selects which indications are given when one or both STO signals are switched off or lost. The indications also depend on whether the drive is running or stopped when this occurs.

Note: This parameter does not affect the operation of the STO function itself. The STO function will operate regardless of the setting of this parameter: a running drive will stop upon removal of one or both STO signals, and will not start until both STO signals are restored and all faults reset.

Note: The loss of only one STO signal always generates a fault as it is interpreted as a malfunction of STO hardware or wiring.

5. The motor coasts to a stop (if running). The drive cannot restart while the activation switch or safety relay contacts are open. After the contacts close, a reset may be needed (depending on the setting of parameter 31.22). A new start command is required to start the drive.
-

Start-up including acceptance test

To ensure the safe operation of a safety function, validation is required. The final assembler of the machine must validate the function by performing an acceptance test. The acceptance test must be performed

- at initial start-up of the safety function
- after any changes related to the safety function (circuit boards, wiring, components, settings, etc.)
- after any maintenance work related to the safety function.

■ Competence

The acceptance test of the safety function must be carried out by a competent person with adequate expertise and knowledge of the safety function as well as functional safety, as required by IEC 61508-1 clause 6. The test procedures and report must be documented and signed by this person.

■ Acceptance test reports

Signed acceptance test reports must be stored in the logbook of the machine. The report shall include documentation of start-up activities and test results, references to failure reports and resolution of failures. Any new acceptance tests performed due to changes or maintenance shall be logged into the logbook.

■ Acceptance test procedure

After wiring the Safe torque off function, validate its operation as follows.

Note: If the drive is equipped with safety option +Q972, +Q973 or +Q982, do the procedure shown in the FSO-xx module documentation.

Action	<input checked="" type="checkbox"/>
 WARNING! Obey the safety instructions. If you ignore them, injury or death, or damage to the equipment can occur.	<input type="checkbox"/>
Make sure that the drive can be run and stopped freely during start-up.	<input type="checkbox"/>
Stop the drive (if running), switch the input power off and isolate the drive from the power line using a disconnecter.	<input type="checkbox"/>
Check the STO circuit connections against the wiring diagram.	<input type="checkbox"/>
Close the disconnecter and switch the power on.	<input type="checkbox"/>
Test the operation of the STO function when the motor is stopped. <ul style="list-style-type: none"> • Give a stop command for the drive (if running) and wait until the motor shaft is at a standstill. Make sure that the drive operates as follows: <ul style="list-style-type: none"> • Open the STO circuit. The drive generates an indication if one is defined for the 'stopped' state in parameter 31.22 (see the firmware manual). • Give a start command to verify that the STO function blocks the drive's operation. The drive generates a warning. The motor should not start. • Close the STO circuit. • Reset any active faults. Restart the drive and check that the motor runs normally. 	<input type="checkbox"/>

266 *The Safe torque off function*

Action	<input checked="" type="checkbox"/>
<p>Test the operation of the STO function when the motor is running.</p> <ul style="list-style-type: none"> • Start the drive and make sure the motor is running. • Open the STO circuit. The motor should stop. The drive generates an indication if one is defined for the 'running' state in parameter 31.22 (see the firmware manual). • Reset any active faults and try to start the drive. • Make sure that the motor stays at a standstill and the drive operates as described above in testing the operation when the motor is stopped. • Close the STO circuit. • Reset any active faults. Restart the drive and check that the motor runs normally. 	<input type="checkbox"/>
<p>Test the operation of the failure detection of the drive. The motor can be stopped or running.</p> <ul style="list-style-type: none"> • Open the 1st channel of the STO circuit. If the motor was running, it should coast to a stop. The drive generates a <i>FA81 Safe Torque Off 1 loss</i> fault indication (see the firmware manual). • Give a start command to verify that the STO function blocks the drive's operation. The motor should not start. • Close the STO circuit. • Reset any active faults. Restart the drive and check that the motor runs normally. • Open the 2nd channel of the STO circuit. If the motor was running, it should coast to a stop. The drive generates a <i>FA82 Safe Torque Off 2 loss</i> fault indication (see the firmware manual). • Give a start command to verify that the STO function blocks the drive's operation. The motor should not start. • Close the STO circuit. • Reset any active faults. Restart the drive and check that the motor runs normally. 	<input type="checkbox"/>
<p>Document and sign the acceptance test report which verifies that the safety function is safe and accepted for operation.</p>	<input type="checkbox"/>

Use

1. Open the activation switch, or activate the safety functionality that is wired to the STO connection.
2. The STO inputs on the drive control unit de-energize, and the control unit cuts off the control voltage from the output IGBTs.
3. The control program generates an indication as defined by parameter 31.22 (see the firmware manual of the drive).
4. The motor coasts to a stop (if running). The drive will not restart while the activation switch or safety relay contacts are open.
5. Deactivate the STO by closing the activation switch, or resetting the safety functionality that is wired to the STO connection.
6. Reset any faults before restarting.



WARNING!

The Safe torque off function does not disconnect the voltage of the main and auxiliary circuits from the drive. Therefore maintenance work on electrical parts of the drive or the motor can only be carried out after isolating the drive from the supply and all other voltage sources.



WARNING!

(With permanent magnet or synchronous reluctance [SynRM] motors only)

In case of a multiple IGBT power semiconductor failure, the drive can produce an alignment torque which maximally rotates the motor shaft by $180/p$ degrees (with permanent magnet motors) or $180/2p$ degrees (with synchronous reluctance [SynRM] motors) regardless of the activation of the Safe torque off function. p denotes the number of pole pairs.

Notes:

- If a running drive is stopped by using the Safe torque off function, the drive will cut off the motor supply voltage and the motor will coast to a stop. If this causes danger or is not otherwise acceptable, stop the drive and machinery using the appropriate stop mode before activating the Safe torque off function.
 - The Safe torque off function overrides all other functions of the drive.
 - The Safe torque off function is ineffective against deliberate sabotage or misuse.
 - The Safe torque off function has been designed to reduce the recognized hazardous conditions. In spite of this, it is not always possible to eliminate all potential hazards. The assembler of the machine must inform the final user about the residual risks.
-

Maintenance

After the operation of the circuit is validated at start-up, the STO function shall be maintained by periodic proof testing. In high demand mode of operation, the maximum proof test interval is 20 years. In low demand mode of operation, the maximum proof test interval is 5 or 2 years; see section *Safety data (page 270)*. It is assumed that all dangerous failures of the STO circuit are detected by the proof test. To perform the proof test, do the *Acceptance test procedure (page 265)*.

Note: See also the Recommendation of Use CNB/M/11.050 (published by the European co-ordination of Notified Bodies) concerning dual-channel safety-related systems with electromechanical outputs:

- When the safety integrity requirement for the safety function is SIL 3 or PL e (cat. 3 or 4), the proof test for the function must be performed at least every month.
- When the safety integrity requirement for the safety function is SIL 2 (HFT = 1) or PL d (cat. 3), the proof test for the function must be performed at least every 12 months.

The STO function of the drive does not contain any electromechanical components.

In addition to proof testing, it is a good practice to check the operation of the function when other maintenance procedures are carried out on the machinery.

Include the Safe torque off operation test described above in the routine maintenance program of the machinery that the drive runs.

If any wiring or component change is needed after start up, or the parameters are restored, do the test given in section *Acceptance test procedure (page 265)*.

Use only spare parts approved by ABB.

Record all maintenance and proof test activities in the machine logbook.

■ Competence

The maintenance and proof test activities of the safety function must be carried out by a competent person with adequate expertise and knowledge of the safety function as well as functional safety, as required by IEC 61508-1 clause 6.

Fault tracing

The indications given during the normal operation of the Safe torque off function are selected by drive control program parameter 31.22.

The diagnostics of the Safe torque off function cross-compare the status of the two STO channels. In case the channels are not in the same state, a fault reaction function is performed and the drive trips on an "STO hardware failure" fault. An attempt to use the STO in a non-redundant manner, for example activating only one channel, will trigger the same reaction.

See the firmware manual of the drive control program for the indications generated by the drive, and for details on directing fault and warning indications to an output on the control unit for external diagnostics.

Any failures of the Safe torque off function must be reported to ABB.

Safety data

The safety data for the Safe torque off function is given below.

Note: The safety data is calculated for redundant use, and does not apply if both STO channels are not used.

Frame size	SIL/ SILCL	PL	SFF (%)	PFH ($T_1 = 20$ a) (1/h)	PFD _{avg} ($T_1 = 2$ a)	PFD _{avg} ($T_1 = 5$ a)	MTTF _D (a)	DC (%)	Cat.	SC	HFT	CCF	T _M (a)
$U_N = 230$ V													
R1	3	e	>99	2.84E-09	2.37E-05	5.91E-05	10530	≥90	3	3	1	80	20
R2	3	e	>99	2.84E-09	2.37E-05	5.91E-05	10529	≥90	3	3	1	80	20
R3	3	e	>99	2.84E-09	2.37E-05	5.91E-05	10489	≥90	3	3	1	80	20
R4	3	e	>99	2.89E-09	2.41E-05	6.02E-05	10442	≥90	3	3	1	80	20
R5	3	e	>99	2.89E-09	2.41E-05	6.02E-05	10240	≥90	3	3	1	80	20
R6 R7 R8	3	e	>99	2.89E-09	2.41E-05	6.02E-05	10340	≥90	3	3	1	80	20
$U_N = 400$ V, $U_N = 500$ V													
R1	3	e	>99	2.84E-09	2.37E-05	5.91E-05	10530	≥90	3	3	1	80	20
R2	3	e	>99	2.84E-09	2.37E-05	5.91E-05	10529	≥90	3	3	1	80	20
R3	3	e	>99	2.84E-09	2.37E-05	5.91E-05	10489	≥90	3	3	1	80	20
R4	3	e	>99	2.89E-09	2.41E-05	6.02E-05	10442	≥90	3	3	1	80	20
R5	3	e	>99	2.89E-09	2.41E-05	6.02E-05	10240	≥90	3	3	1	80	20
R6 R7	3	e	>99	2.89E-09	2.41E-05	6.02E-05	10340	≥90	3	3	1	80	20
R8 R9	3	e	99.1	3.21E-09	2.67E-05	6.67E-05	9630	≥90	3	3	1	80	20
$U_N = 690$ V													
R3	3	e	98.5	3.24E-09	2.68E-05	6.69E-05	6221	≥90	3	3	1	80	20
R5	3	e	98.5	3.23E-09	2.67E-05	6.68E-05	5879	≥90	3	3	1	80	20
R6 R7 R8 R9	3	e	99.1	3.21E-09	2.66E-05	6.66E-05	10008	≥90	3	3	1	80	20
3AXD1000006217 K, 3AXD10000083197 H													

- The following temperature profile is used in safety value calculations:
 - 670 on/off cycles per year with $\Delta T = 71.66$ °C
 - 1340 on/off cycles per year with $\Delta T = 61.66$ °C
 - 30 on/off cycles per year with $\Delta T = 10.0$ °C
 - 32 °C board temperature at 2.0% of time
 - 60 °C board temperature at 1.5% of time
 - 85 °C board temperature at 2.3% of time.
- The STO is a type A safety component as defined in IEC 61508-2.
- Relevant failure modes:
 - The STO trips spuriously (safe failure)
 - The STO does not activate when requested
 - A fault exclusion on the failure mode “short circuit on printed circuit board” has been made (EN 13849-2, table D.5). The analysis is based on an assumption that one failure occurs at one time. No accumulated failures have been analyzed.

- STO response times:
 - STO reaction time (shortest detectable break): 1 ms
 - STO response time: 2 ms (typical), 5 ms (maximum)
 - Fault detection time: Channels in different states for longer than 200 ms
 - Fault reaction time: Fault detection time + 10 ms
- Indication delays:
 - STO fault indication (parameter 31.22) delay: < 500 ms
 - STO warning indication (parameter 31.22) delay: < 1000 ms

■ Abbreviations

Abbr.	Reference	Description
Cat.	EN ISO 13849-1	Classification of the safety-related parts of a control system in respect of their resistance to faults and their subsequent behavior in the fault condition, and which is achieved by the structural arrangement of the parts, fault detection and/or by their reliability. The categories are: B, 1, 2, 3 and 4.
CCF	EN ISO 13849-1	Common cause failure (%)
DC	EN ISO 13849-1	Diagnostic coverage
HFT	IEC 61508	Hardware fault tolerance
MTTF _D	EN ISO 13849-1	Mean time to dangerous failure: (Total number of life units) / (Number of dangerous, undetected failures) during a particular measurement interval under stated conditions
PFD _{avg}	IEC 61508	Average probability of dangerous failure on demand, that is, mean unavailability of a safety-related system to perform the specified safety function when a demand occurs
PFH	IEC 61508	Average frequency of dangerous failures per hour, that is, average frequency of a dangerous failure of a safety related system to perform the specified safety function over a given period of time
PL	EN ISO 13849-1	Performance level. Levels a...e correspond to SIL
SC	IEC 61508	Systematic capability
SFF	IEC 61508	Safe failure fraction (%)
SIL	IEC 61508	Safety integrity level (1...3)
SILCL	IEC/EN 62061	Maximum SIL (level 1...3) that can be claimed for a safety function or subsystem
STO	IEC/EN 61800-5-2	Safe torque off
T ₁	IEC 61508-6	Proof test interval. T ₁ is a parameter used to define the probabilistic failure rate (PFH or PFD) for the safety function or subsystem. Performing a proof test at a maximum interval of T ₁ is required to keep the SIL capability valid. The same interval must be followed to keep the PL capability (EN ISO 13849) valid. See also section Maintenance.
T _M	EN ISO 13849-1	Mission time: the period of time covering the intended use of the safety function/device. After the mission time elapses, the safety device must be replaced. Note that any T _M values given cannot be regarded as a guarantee or warranty.

■ TÜV certificate

The TÜV certificate is available on the Internet at www.abb.com/drives/documents.

■ Declaration of conformity



EU Declaration of Conformity

Machinery Directive 2006/42/EC

We

Manufacturer: ABB Oy
Address: Hiomotie 13, 00380 Helsinki, Finland.
Phone: +358 10 22 11

declare under our sole responsibility that the following product:

Frequency converter(s)
ACS880-01/-11/-31
ACS880-04/-04F/-M04/-14/-34

with regard to the safety function(s)

- **Safe Torque Off**
- **Safe stop 1, Safe stop emergency, Safely-limited speed, Safe maximum speed, Safe brake control, Prevention of unexpected start-up (with FSO-12 option module, +Q973, encoderless)**
- **Safe stop 1, Safe stop emergency, Safely-limited speed, Safe maximum speed, Safe brake control, Safe speed monitor, Safe direction, Prevention of unexpected start-up (with FSO-21 and FSE-31 option modules, +Q972 and +L521, encoder supported)**
- **Safe motor temperature (with FPTC-01 thermistor protection module, +L536)**
- **Safe stop 1 (SS1-t, with FSPS-21 PROFIsafe module, +Q986)**

is/are in conformity with all the relevant safety component requirements of EU Machinery Directive 2006/42/EC, when the listed safety function is used for safety component functionality.

The following harmonized standards have been applied:

EN 61800-5-2:2007	Adjustable speed electrical power drive systems – Part 5-2: Safety requirements - Functional
EN 62061:2005 + AC:2010 + A1:2013 + A2:2015	Safety of machinery – Functional safety of safety-related electrical, electronic and programmable electronic control systems
EN ISO 13849-1:2015	Safety of machinery – Safety-related parts of control systems. Part 1: General requirements
EN ISO 13849-2:2012	Safety of machinery – Safety-related parts of the control systems. Part 2: Validation
EN 60204-1: 2006 + A1:2009 + AC:2010	Safety of machinery – Electrical equipment of machines – Part 1: General requirements

The following other standards have been applied:

IEC 61508:2010, parts 1-2	Functional safety of electrical / electronic / programmable electronic safety-related systems
IEC 61800-5-2:2016	Adjustable speed electrical power drive systems – Part 5-2: Safety requirements - Functional

The product(s) referred in this Declaration of conformity fulfil(s) the relevant provisions of other European Union Directives which are notified in Single EU Declaration of conformity 3AXD10000497831.

Person authorized to compile the technical file:

Name and address: Jussi Vesti, Hiomotie 13, 00380 Helsinki, Finland.

Helsinki, 29.01.2020

Signed for and on behalf of:

Tuomo Tarula
Vice president,

Vesa Tuomainen
Product Engineering manager, ABB Oy

Document number 3AXD1000099646

17

Filters

Contents of this chapter

This chapter describes how to select external filters for the drive.

When is a common mode filter or du/dt filter needed?

See section *Examining the compatibility of the motor and drive (page 60)*. A common mode filter kits are available from ABB. The kits includes three wound cores. For installation instructions of the cores, see the instruction included in the core package.

Common mode filters

Common mode filter kits are available from ABB. The kits includes three wound cores.

Name	Code
Common mode filter kit for ACS880-01, ACS880-11 and ACS880-31 drives (frame R6, option +E208) installation instructions	3AXD50000015178
Common mode filter kit for ACS880-01 frame R7, and for ACS880-11, ACS880-31, ACH580-31 and ACQ580-31 frame R8 (option +E208) installation instructions	3AXD50000015179
Common mode filter kit for ACS880-01 drives (frame R9, option +E208) installation instructions	3AXD50000015201

du/dt filters

■ du/dt filter types

ACS880-01-...	du/dt filter type	ACS880-01-...	du/dt filter type	ACS880-01-...	du/dt filter type
$U_N = 400\text{ V}$		$U_N = 500\text{ V}$		$U_N = 690\text{ V}$	
02A4-3	NOCH0016-6X	02A1-5	NOCH0016-6X	07A4-7	NOCH0016-6X

ACS880-01-...	du/dt filter type	ACS880-01-...	du/dt filter type	ACS880-01-...	du/dt filter type
03A3-3	NOCH0016-6X	03A0-5	NOCH0016-6X	09A9-7	NOCH0016-6X
04A0-3	NOCH0016-6X	03A4-5	NOCH0016-6X	14A3-7	NOCH0016-6X
05A6-3	NOCH0016-6X	04A8-5	NOCH0016-6X	019A-7	NOCH0030-6X
07A2-3	NOCH0016-6X	05A2-5	NOCH0016-6X	023A-7	NOCH0030-6X
09A4-3	NOCH0016-6X	07A6-5	NOCH0016-6X	027A-7	NOCH0030-6X
12A6-3	NOCH0016-6X	11A0-5	NOCH0016-6X	07A3-7	NOCH0016-6X
017A-3	NOCH0030-6X	014A-5	NOCH0030-6X	09A8-7	NOCH0016-6X
025A-3	NOCH0030-6X	021A-5	NOCH0030-6X	14A2-7	NOCH0016-6X
032A-3	NOCH0070-6X	027A-5	NOCH0070-6X	018A-7	NOCH0030-6X
038A-3	NOCH0070-6X	034A-5	NOCH0070-6X	022A-7	NOCH0030-6X
045A-3	NOCH0070-6X	040A-5	NOCH0070-6X	026A-7	NOCH0030-6X
061A-3	NOCH0070-6X	052A-5	NOCH0070-6X	035A-7	NOCH0070-6X
072A-3	NOCH0120-6X	065A-5	NOCH0120-6X	042A-7	NOCH0070-6X
087A-3	NOCH0120-6X	077A-5	NOCH0120-6X	049A-7	NOCH0070-6X
105A-3	NOCH0120-6X	096A-5	NOCH0120-6X	061A-7	NOCH0120-6X
145A-3	FOCH0260-7X	124A-5	FOCH0260-7X	084A-7	NOCH0120-6X
169A-3	FOCH0260-7X	156A-5	FOCH0260-7X	098A-7	NOCH0120-6X
206A-3	FOCH0260-7X	180A-5	FOCH0260-7X	119A-7	FOCH0260-7X
246A-3	FOCH0260-7X	240A-5	FOCH0260-7X	142A-7	FOCH0260-7X
293A-3	FOCH0260-7X	260A-5	FOCH0260-7X	174A-7	FOCH0260-7X
363A-3	FOCH0320-5X	302A-5	FOCH0320-5X	210A-7	FOCH0260-7X
430A-3	FOCH0320-5X	361A-5	FOCH0320-5X	271A-7	FOCH0260-7X
		414A-5	FOCH0320-5X		

■ Description, installation and technical data of the du/dt filters

See

- *FOCH du/dt filters hardware manual* ([3AFE68577519](#) [English])
- *AOCH and NOCH du/dt filters hardware manual* ([3AFE58933368](#) [English]).

Sine filters

■ Selecting a sine filter for a drive

Check housing of sine filters from the manufacturer's internet pages. Go to <https://en.tdk.eu>

ACS880-01-...	Sine filter type	$I_{\text{cont. max}}$	$P_{\text{cont. max}}$	Heat dissipation			Noise
				Drive	Filter	Total	
				A	kW	W	W
$U_N = 400 \text{ V}$							
02A4-3	B84143V0004R229*	2.3	1.7	30	60	90	72
03A3-3	B84143V0004R229*	3.1	2.3	40	60	100	72
* minimum switching frequency 3.0 kHz							
** minimum switching frequency 2.4 kHz							

ACS880-01-...	Sine filter type	$I_{\text{cont. max}}$	$P_{\text{cont. max}}$	Heat dissipation			Noise
				Drive	Filter	Total	
		A	kW	W	W	W	dB (A)
04A0-3	B84143V0004R229*	3.8	2.9	52	60	112	72
05A6-3	B84143V0006R229*	5.3	4.0	73	100	173	72
07A2-3	B84143V0011R229*	7.2	5.4	94	90	184	72
09A4-3	B84143V0011R229*	9.2	6.9	122	90	212	72
12A6-3	B84143V0016R229*	12.1	9.1	172	80	252	72
017A-3	B84143V0025R229*	16	12.1	232	140	372	75
025A-3	B84143V0025R229*	24	17.7	337	140	477	75
032A-3	B84143V0033R229*	31	23.4	457	160	617	75
038A-3	B84143V0050R229*	37	27.5	562	220	782	78
045A-3	B84143V0050R229*	43	32.4	667	220	887	78
061A-3	B84143V0066R229*	58	43.7	907	250	1157	78
072A-3	B84143V0075R229*	64	48.2	1117	310	1427	79
087A-3	B84143V0095R229*	77	58.0	1120	400	1520	79
105A-3	B84143V0130S230**	91	68.6	1295	600	1895	80
145A-3	B84143V0162S229**	126	94.6	1440	550	1990	80
169A-3	B84143V0162S229**	153	115.0	1940	550	2490	80
206A-3	B84143V0230S229**	187	140.6	2310	900	3210	80
246A-3	B84143V0230S229**	209	157.6	3300	900	4200	80
293A-3	B84143V0390S229**	249	187.8	3900	1570	5470	80
363A-3	B84143V0390S229**	297	223.6	4800	1570	6370	80
430A-3	B84143V0390S229**	352	265.2	6000	1570	7570	80
$U_N = 500 \text{ V}$							
02A1-5	B84143V0004R229*	1.9	1.4	30	60	90	72
03A0-5	B84143V0004R229*	2.8	2.1	40	60	100	72
03A4-5	B84143V0004R229*	3.1	2.3	52	60	112	72
04A8-5	B84143V0006R229*	4.4	3.3	73	100	173	72
05A2-5	B84143V0006R229*	4.8	3.6	94	100	194	72
07A6-5	B84143V0011R229*	7.0	5.3	122	90	212	72
11A0-5	B84143V0011R229*	10.2	7.7	172	90	262	72
014A-5	B84143V0016R229*	13	9.8	232	80	312	70
021A-5	B84143V0025R229*	20	14.7	337	140	477	75
027A-5	B84143V0033R229*	25	18.8	457	160	617	75
034A-5	B84143V0050R229*	32	23.7	562	220	782	78
040A-5	B84143V0050R229*	35	26.0	667	220	887	78
052A-5	B84143V0066R229*	44	33.2	907	250	1157	78
065A-5	B84143V0066R229*	52	39.2	1117	250	1367	78
077A-5	B84143V0075R229*	61	46.0	1120	310	1430	78
096A-5	B84143V0130R230**	80	60.6	1295	630	1925	80
* minimum switching frequency 3.0 kHz							
** minimum switching frequency 2.4 kHz							

276 Filters

ACS880-01-...	Sine filter type	$I_{\text{cont. max}}$	$P_{\text{cont. max}}$	Heat dissipation			Noise
				Drive	Filter	Total	
		A	kW	W	W	W	dB (A)
124A-5	B84143V0130S230**	104	78.7	1440	630	2070	80
156A-5	B84143V0162S229**	140	105.8	1940	550	2490	80
180A-5	B84143V0162S229**	161	121.3	2310	550	2860	80
240A-5	B84143V0230S229**	205	154.3	3300	900	4200	80
260A-5	B84143V0230S229**	221	166.7	3900	900	4800	80
361A-5	B84143V0390S229**	289	217.9	4800	1570	6370	80
414A-5	B84143V0390S229**	332	250.1	6000	1570	7570	80
$U_N = 690 \text{ V}$							
07A4-7	B84143V0010R230*	7.3	5.5	114	90	204	72
09A9-7	B84143V0010R230*	9.3	7.0	143	90	233	72
14A3-7	B84143V0018R230*	13.5	10.2	207	130	337	72
019A-7	B84143V0018R230*	17.1	12.9	274	130	404	72
023A-7	B84143V0026R230*	21	15.7	329	160	489	72
027A-7	B84143V0026R230*	25	18.6	405	160	565	72
07A3-7	B84143V0010R230*	7.3	5.5	217	90	307	72
09A8-7	B84143V0010R230*	9.3	7.0	284	90	374	72
14A2-7	B84143V0018R230*	13.5	10.2	399	130	529	72
018A-7	B84143V0018R230*	17.1	12.9	490	130	620	72
022A-7	B84143V0026R230*	21	15.7	578	160	738	72
026A-7	B84143V0026R230*	25	18.6	660	160	820	72
035A-7	B84143V0040R230*	33	25.1	864	250	1114	75
042A-7	B84143V0040R230*	40	30.1	998	250	1248	75
049A-7	B84143V0056R230**	48	36.2	1120	290	1410	78
061A-7	B84143V0056R230**	56	42.5	1295	290	1585	78
084A-7	B84143V0092R230**	78	58.6	1440	610	2050	79
098A-7	B84143V0092R230**	92	69.3	1940	610	2550	79
119A-7	B84143V0130S230**	112	84.2	2310	630	2940	80
142A-7	B84143V0130S230**	112	84.7	3300	630	3930	80
174A-7	B84143V0207S230**	138	103.7	3900	930	4830	80
210A-7	B84143V0207S230**	161	121.3	4200	930	5130	80
271A-7	B84143V0207S230**	208	156.4	4800	930	5730	80
3AXD00000588487							
* minimum switching frequency 3.0 kHz							
** minimum switching frequency 2.4 kHz							

■ Definitions

$P_{\text{cont. max}}$	Maximum continuous output power of the drive
$I_{\text{cont. max}}$	Maximum continuous output current of the drive
Noise	Noise level of the sine filters

Derating

See section *Deratings for special settings in the drive control program (page 175)*.

Description, installation and technical data

See *Sine filters hardware manual* ([3AXD50000016814](#) [English]).



Further information

Product and service inquiries

Address any inquiries about the product to your local ABB representative, quoting the type designation and serial number of the unit in question. A listing of ABB sales, support and service contacts can be found by navigating to www.abb.com/searchchannels.

Product training

For information on ABB product training, navigate to new.abb.com/service/training.

Providing feedback on ABB manuals

Your comments on our manuals are welcome. Navigate to new.abb.com/drives/manuals-feedback-form.

Document library on the Internet

You can find manuals and other product documents in PDF format on the Internet at www.abb.com/drives/documents.



www.abb.com/drives

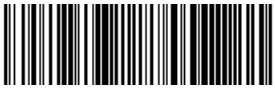

3AUA0000078093P